



**ATAS International, Inc.**  
Sustainable Building Envelope Technology

# INTERIOR APPLICATIONS

Walls & Ceilings

# CONTENTS

## INTERIOR APPLICATIONS

Wall Applications .....	4-5
-------------------------	-----

## PERFORATED & ACOUSTICAL WALLS

Gaten Series™ & Microperforations .....	6
Acoustical Wall Panels & Baffles .....	7
Metal Composite Material .....	8

## ACOUSTICAL & NON-ACOUSTICAL CEILINGS

SOUNDTEX® & CFAB Cellulose Insulation Sound Absorption .....	9
Acoustical Performance Test Method .....	9
Lineair Linear Ceiling™ .....	10-13
Lineair Opaline™ .....	14-15

## SPECIALTY CEILINGS

Lineair Torsion Spring System .....	16
Lineair Lift & Shift.....	17
Lineair Suspended Edge .....	18
Lineair Metal Panel Lay-in System.....	19
Lineair Plank.....	20

## OVERVIEW

With uninterrupted shadow lines and a sleek, continuous appearance, concealed and exposed fastener wall and ceiling panels offer design solutions for any number of project objectives:

- Vertical or horizontal applications
  - Ribbed and corrugated panel styles
  - Standing seam; batten, plank, or barn board styles
  - With or without perforations
  - Curved applications
  - Acoustical applications
  - Large format application available in wide material thickness options
  - Metal composite material
- ...and more.

In addition to the vast selection of styles and material choices, a number of the ATAS profiles can be mixed and matched seamlessly, with single or multi-color design palettes.

ATAS is proud to introduce the new Lineair series of metal ceiling systems. As the amount of metal being used in interior applications, for both ceilings and walls, is increasing, it made sense to expand our ceiling system offering. The Lineair Series brand name of ceiling products was chosen as a nod to our founders' Dutch heritage, as Lineair is Dutch for Linear. As well, Lineair is a perfect product descriptor, as our ceiling systems are actually creating lines in the air.

## LONGEVITY FEATURES

- Fire resistant - will not burn or support combustion
- Minimal maintenance
- Will not warp, crack, or rot
- Industry leading long-term warranty
- High quality and time-proven finish and pretreatment technologies

University of Arkansas Art Department  
Fayetteville, AR  
Perforated Belvedere 6" Short Rib in Ascot White



# WALL APPLICATIONS

## OVERVIEW

From a functional and aesthetically pleasing linear ceiling system, to a wide variety of attractive wall panel options, a building's interior can benefit from the beauty and durability of metal. Curved, tapered, texture, color, wood look, and custom capabilities expand your options and bring design ideas to life. Acoustical sound control systems available for ceilings and walls, with NRC (Noise Reduction Coefficient) ratings of up to 1.0. Here are just some examples of ATAS standard profiles that can be used in interior applications.

## CONCEALED FASTENER WALL PANELS

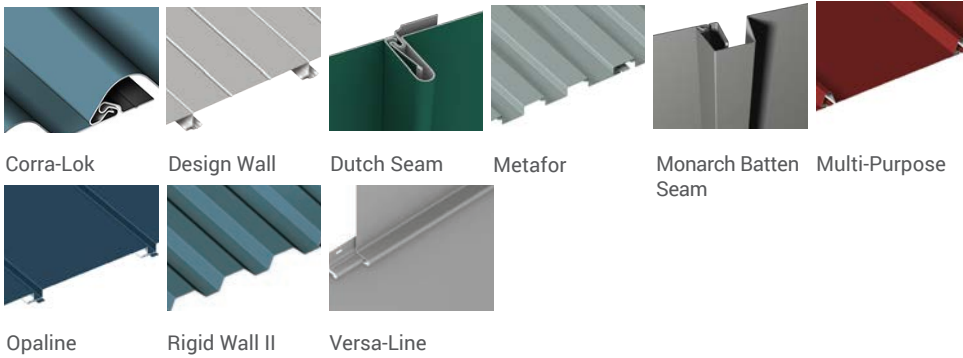

## MODULAR WALL PANELS

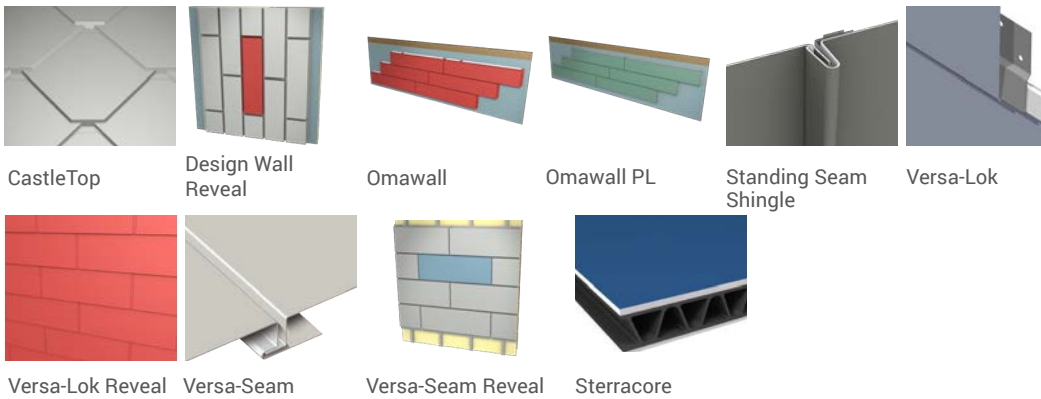

## EXPOSED FASTENER WALL PANELS

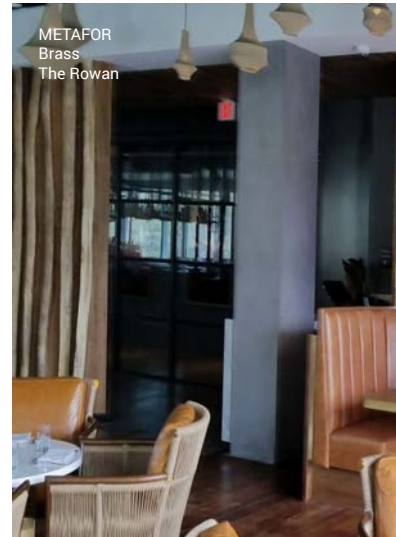

METAFOR  
Brass  
The Rowan



BELVEDERE 7.2\"/>



METAFOR  
Silversmith  
Shake Shack



CASTLETOP & OPALINE  
Black, Silversmith, Coppertone  
ATAS International, Inc., Mesa, AZ



CURVED-CORRUGATED PANEL  
55% Al-Zn Alloy Coated Steel With Acrylic Coated Steel  
Mid Ohio Food Bank Warehouse

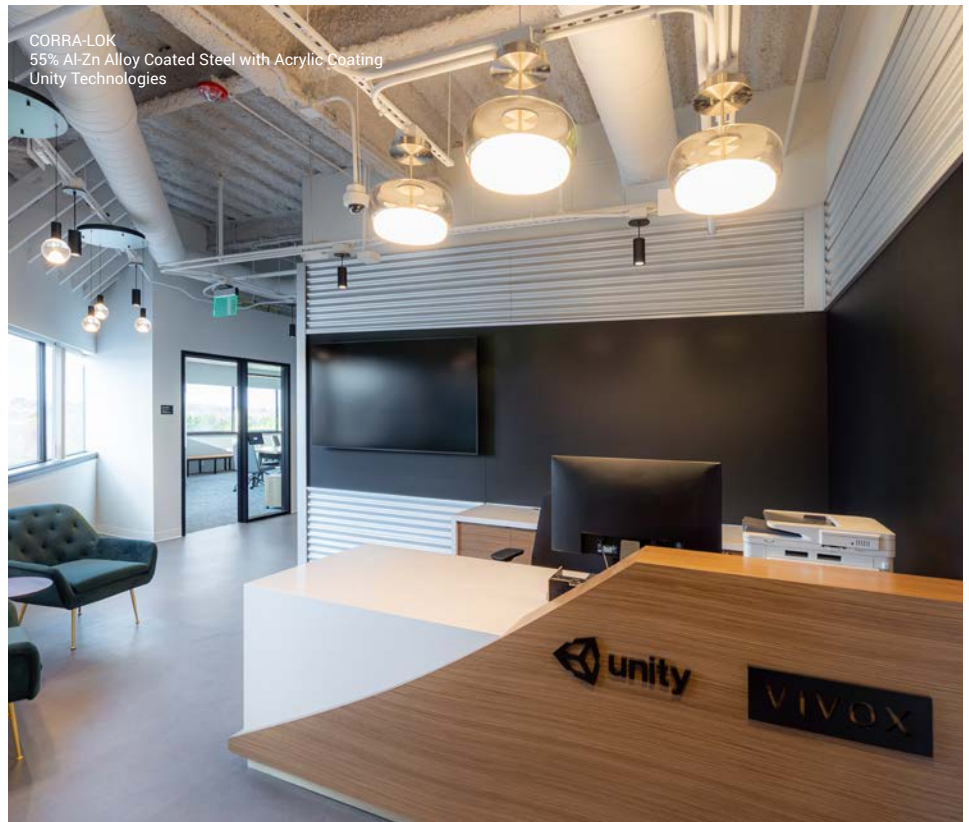

CORRA-LOK  
55% Al-Zn Alloy Coated Steel with Acrylic Coating  
Unity Technologies

# PERFORATED & ACOUSTICAL WALLS

## GATEN SERIES™ & MICROPERFORATIONS

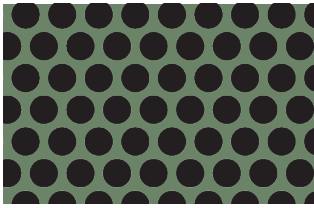

**A13**  
 $\frac{1}{8}$ " holes |  $\frac{3}{16}$ " staggered centers  
 40% open area

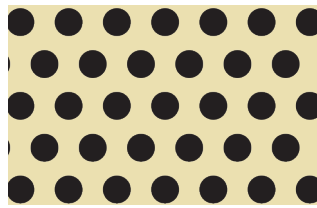

**A15**  
 $\frac{1}{8}$ " holes |  $\frac{1}{4}$ " staggered centers  
 23% open area

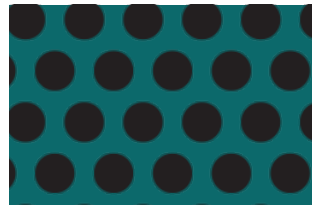

**A19**  
 $\frac{3}{16}$ " holes |  $\frac{5}{16}$ " staggered centers  
 33% open area

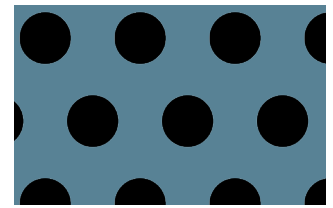

**A23**  
 $\frac{1}{4}$ " holes |  $\frac{1}{2}$ " staggered centers  
 23% open area

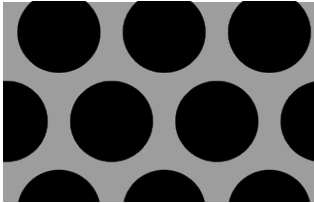

**A24**  
 $\frac{3}{8}$ " holes |  $\frac{1}{2}$ " staggered centers  
 51% open area

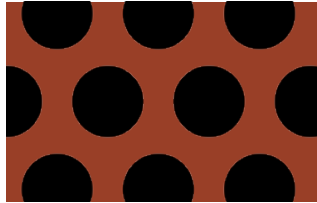

**A25**  
 $\frac{3}{8}$ " holes |  $\frac{9}{16}$ " staggered centers  
 40% open area

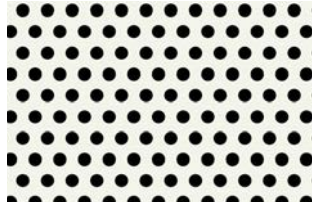

**MICROPERFORATED**  
 $\frac{1}{16}$ " holes |  $\frac{1}{8}$ " staggered centers | 22% open area  
 Interior use only | For sound absorption

### CONCEALED FASTENER

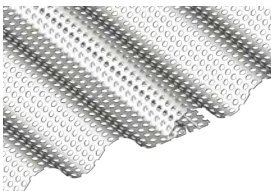

Corra-Lok

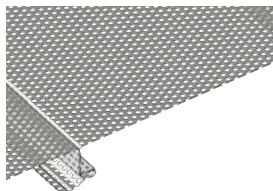

Design Wall

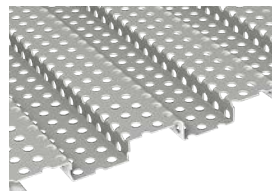

Metafor

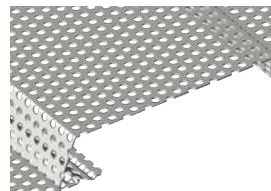

Multi-Purpose Panels



Opaline

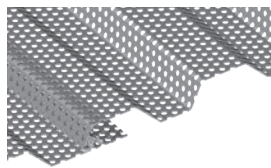

Rigid Wall II

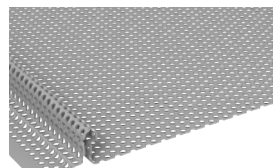

Versa-Line

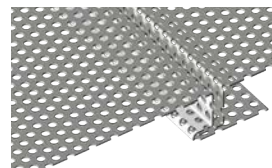

Versa-Seam

### EXPOSED FASTENER

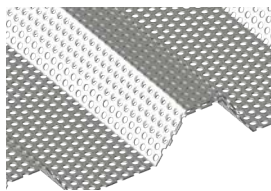

Belvedere 6" Short Rib

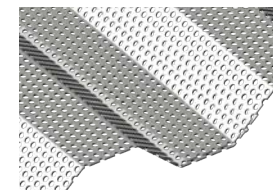

Belvedere 7.2" Rib

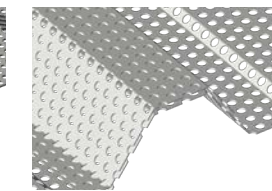

Belvedere Grand R

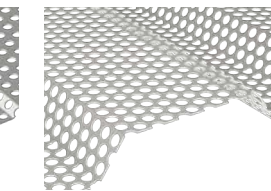

Belvedere PenumWall

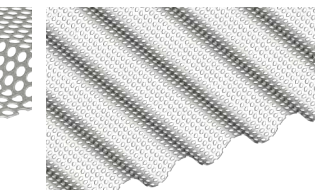

Corrugated Panel

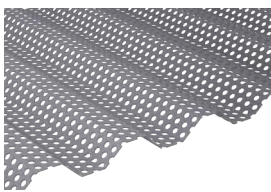

Grand C

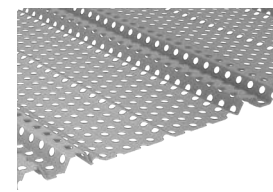

Grand V

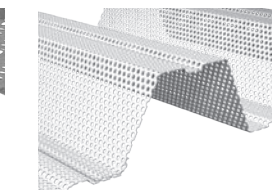

Span Wall

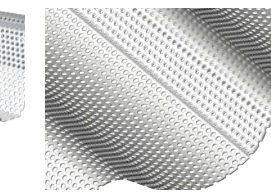

Wave Panel

RIGID WALL II  
Black  
Dave & Buster's



# ACOUSTICAL WALL PANELS & BAFFLES

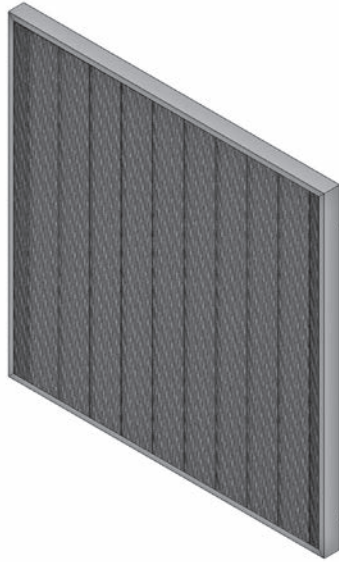

Suspended Horizontal Panel

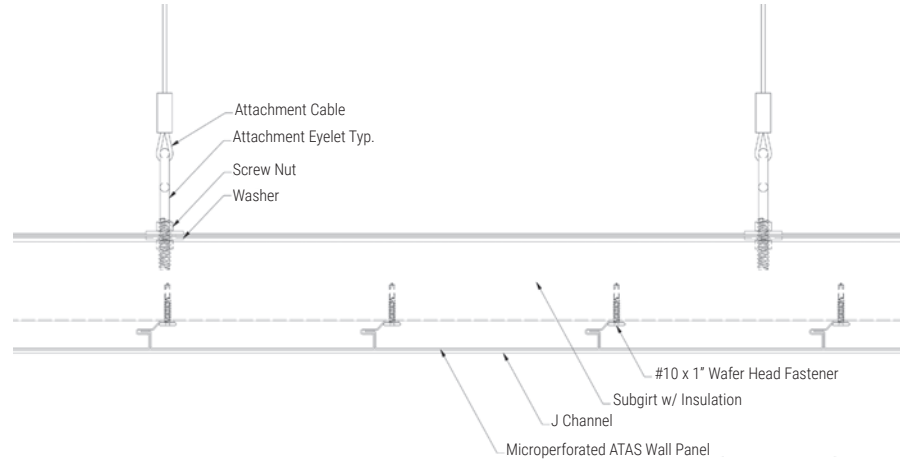

Z Bracket Wall Panel Frame Detail

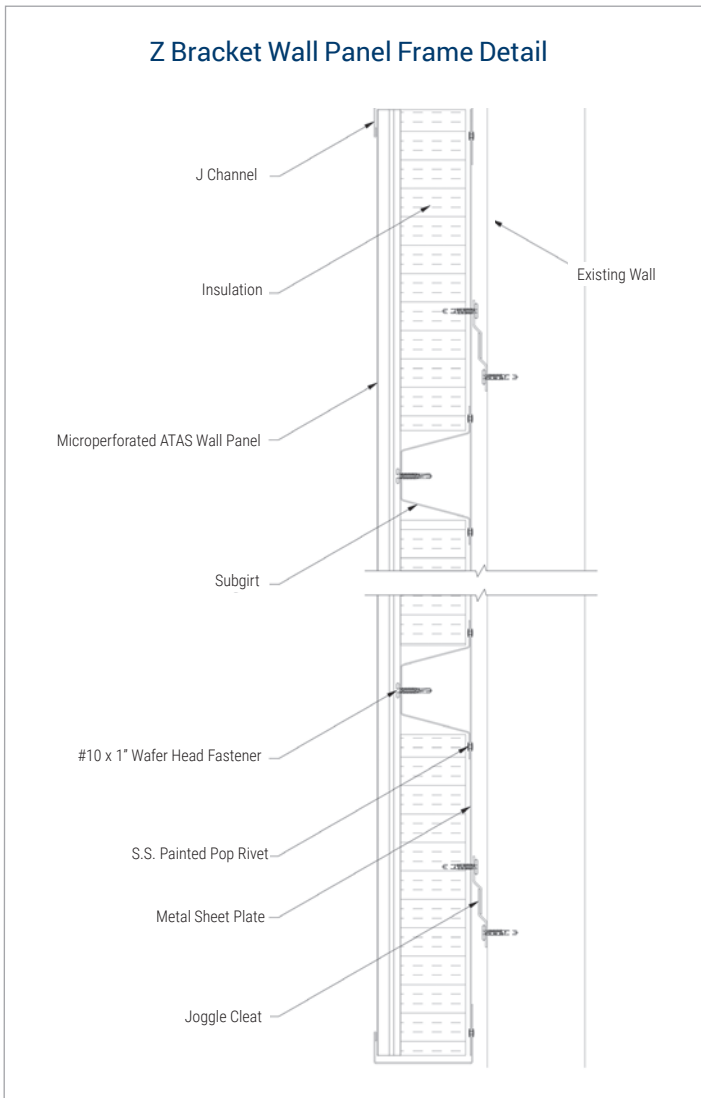

Suspended Vertical Baffle

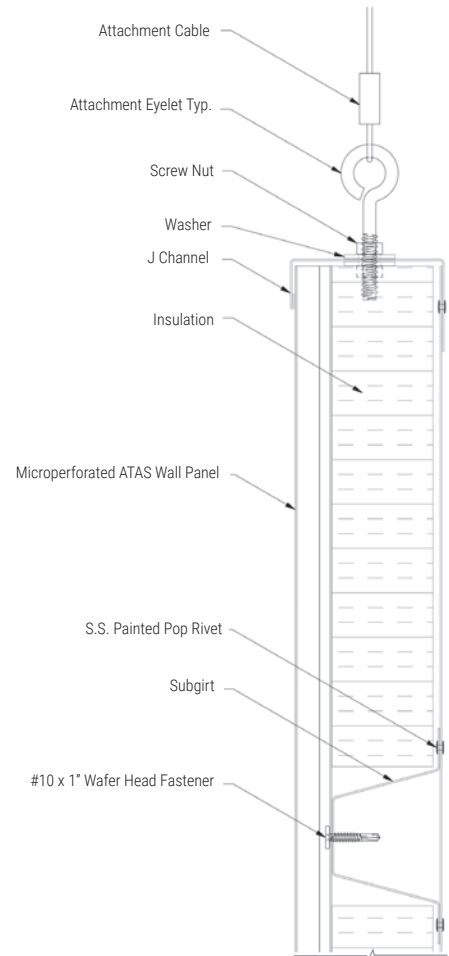



# METAL COMPOSITE MATERIAL

## STERRACORE

SKU: MAU999

### MATERIAL

.032 aluminum exterior skin

### PANEL SPECS

Coverage: 48" x 96",  
48" x 120", 48" x 144"  
Custom sizes available

### THICKNESS

6mm

### TEXTURE

Smooth or Stucco  
Embossed

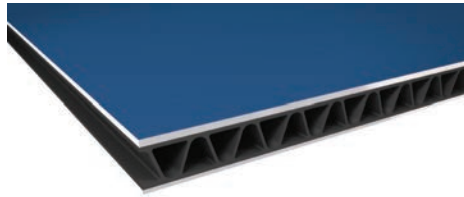

1-Piece, Module Trim



Clip & Seal



MCM & Plate Column  
Cover Hairline

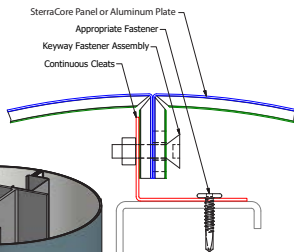
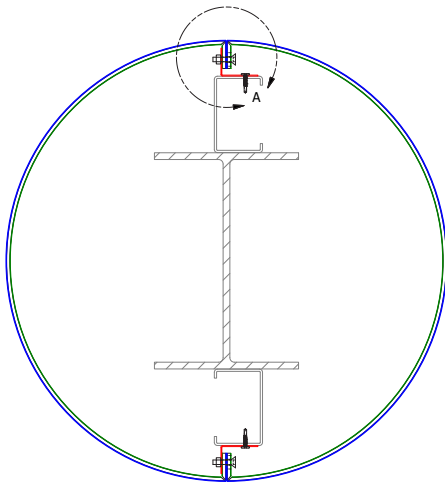

MCM & Plate Column Cover  
Backer Rod & Sealant

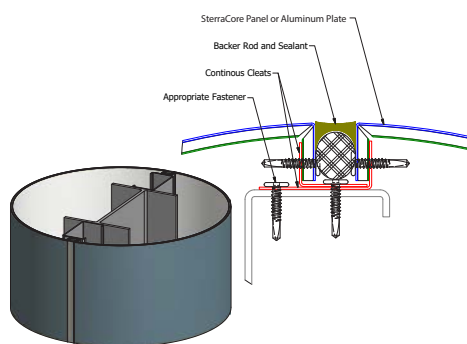
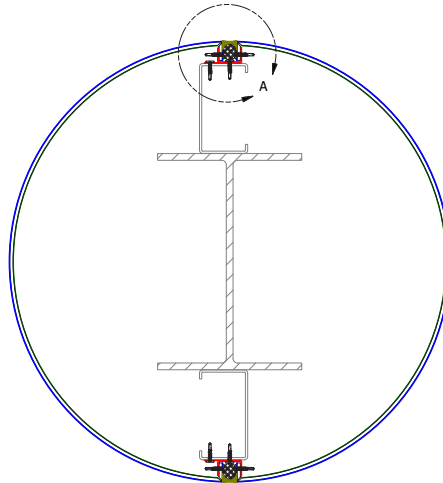

MCM & Plate Column Cover  
Batten

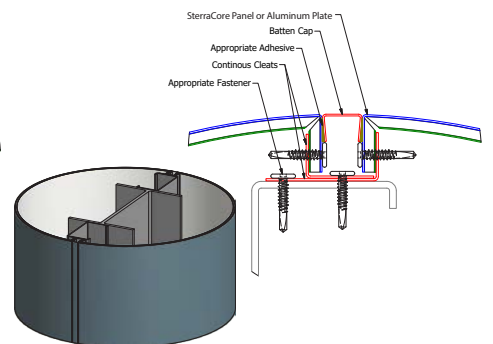
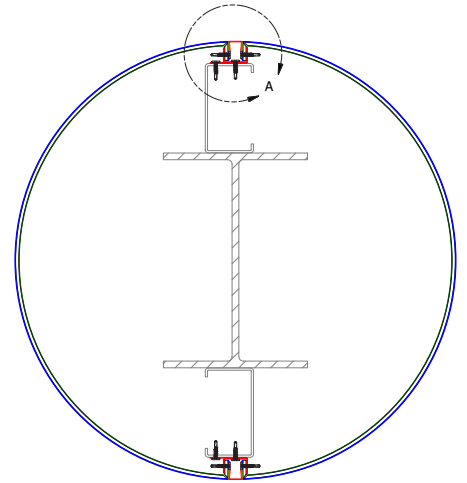

# ACOUSTICAL & NON-ACOUSTICAL CEILINGS

## SOUNDTEX®

SOUNDTEX® is an innovative acoustical insulation - a non-woven fabric that can be used in lieu of traditional acoustical materials where concerns about airborne glass fibers or space constraints exist. SOUNDTEX® is essentially a paper thin air filter that provides an increased resistance to airflow which dissipates sound energy by converting it into heat.

### FEATURES

- Reduces reverberation
- Hot melt adhesive backing
- Available in Black
- Variety of sizes and custom options available

### APPLICATIONS

- Residential
- Commercial
- Home theaters
- TV/ Media rooms
- Reverberant space

### MATERIAL

- Ultra-thin (0.27mm incl. adhesive)
- Non-woven fabric made of cellulose and glass designed for acoustical performance

### TECHNICAL PROPERTIES

- Structure of non-woven: random
- Weight: 63 g/m<sup>2</sup>
- Thickness: 0.27 mm
- Sound Impedance: 190 Ns/m<sup>3</sup>

### THE MAGIC OF SOUNDTEX®

Applied to the back of a perforated panel, the composition and superior uniformity of SOUNDTEX® allows this ultra-thin acoustical fabric to replace very bulky mineral mats, greatly saving on freight and installation costs. The air permeability of SOUNDTEX® reduces moisture in the plenum, enhances flexibility in building HVAC design, and permits thermal transfer in energy-efficient chilled ceilings.

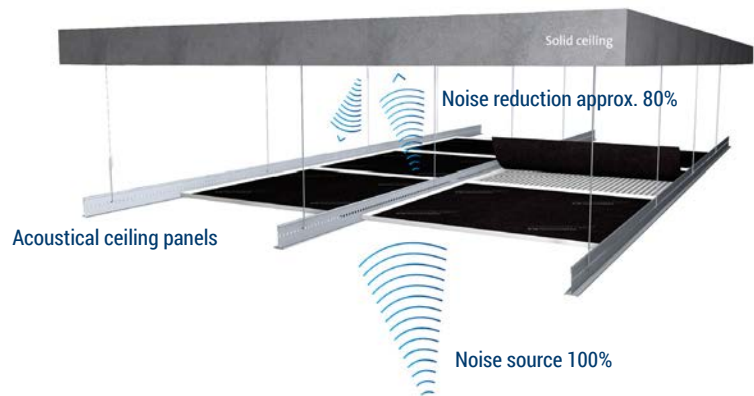

## CFAB CELLULOSE INSULATION SOUND ABSORPTION



### FEATURES

- Resists mold growth
- Made from renewable and recycled fibers consisting of 65-75% recycled content
- Available in 2' x 4', 4' x 4', and 4' x 8' panels
- Available in ½", 1", or 2" thickness
- Density: 3PCF -m2" thickness

### PRODUCT SAFETY

- Class A fire rating
- Does not contain any harmful airborne particles and does not itch or irritate skin like fiber glass insulation

### GREEN QUALITIES

- Environmentally responsible and sustainable
- Most CFAB cellulose foam board products are completely recyclable and no scrap is produced during the manufacturing process or installation of the material
- Sustainable manufacturing process reduces energy use and air pollution
- Made primarily from post-consumer, post-industrial paper using recycled newspaper as the main raw material

### ACOUSTICAL PERFORMANCE

- Open design and density increases sound absorption to control and deaden sound
- CFAB cellulose foam board panels achieve high Noise Reduction Coefficient (NRC) ratings based on the density specified
- Sound Transmission Classification (STC) ratings exceed the values attained with commonly used acoustical materials

\*Info provided for SOUNDTEX® and CFAB are for descriptive purposes; CFAB materials typically supplied by installer/contractor or distributor.

**ROUND EDGE:**

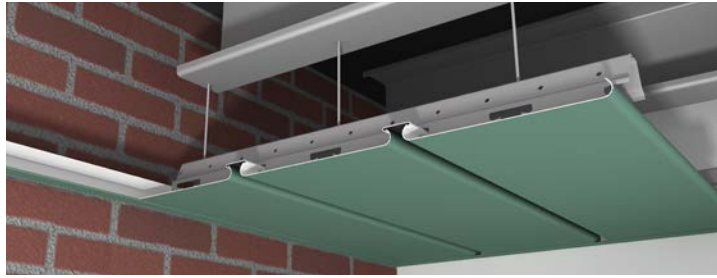

LCR with recessed filler strip



LCR with flush filler strip



LCR with mix and match widths

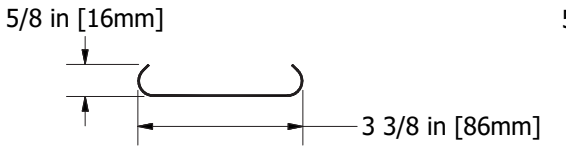

Linear Linear Ceiling (LCR338)

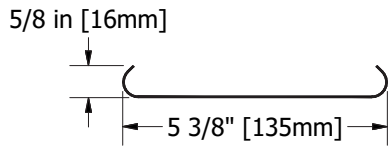

Linear Linear Ceiling (LCR538)

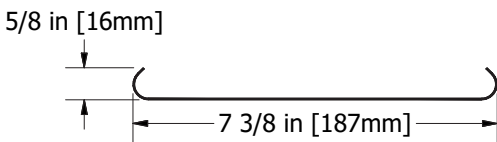

Linear Linear Ceiling (LCR738)

**BOX STYLE:**



LCB with recessed filler strip



LCB with mix and match widths

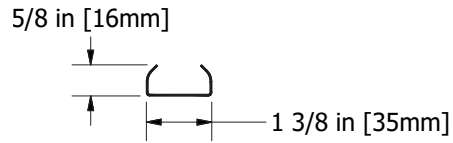

Linear Linear Ceiling (LCB138)

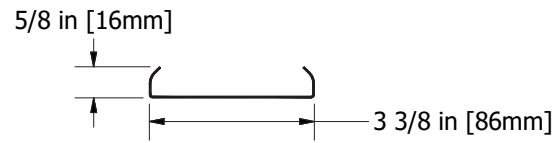

Linear Linear Ceiling (LCB338)

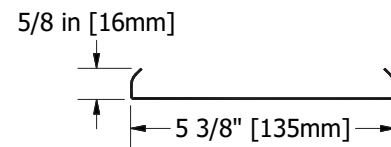

Linear Linear Ceiling (LCR538)

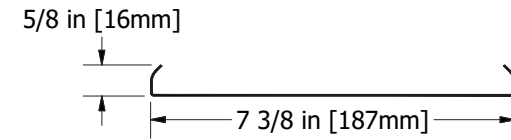

Linear Linear Ceiling (LCB738)

**FILLER STRIPS:**

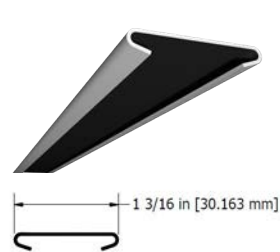

Recessed Filler Strip (LCR and LCB)

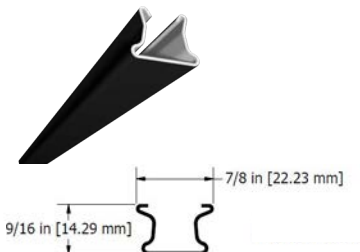

Flush Filler Strip (LCR)

## LINEAIR LINEAR CEILING™

SKU: Round Edge: LCR338, LCR538, LCR738

Box Style: LCB138, LCB338, LCB538, LCB738

### MATERIAL

.019 (only available for LCB338 & LCR338),  
.024, .032 aluminum

### PANEL SPECS

LCR Width: 3<sup>3</sup>/<sub>8</sub>" , 5<sup>3</sup>/<sub>8</sub>" , 7<sup>3</sup>/<sub>8</sub>" | 4", 6", 8" coverage with  
filler strips

LCB Width: 1<sup>3</sup>/<sub>8</sub>" , 3<sup>3</sup>/<sub>8</sub>" , 5<sup>3</sup>/<sub>8</sub>" , 7<sup>3</sup>/<sub>8</sub>" | 2", 4", 6", 8"  
coverage with filler strips

Length: Minimum 4'-0", maximum 20'-0" (LCB138 is  
limited to a 12' length)

Height: 5/8"

### AVAILABLE

Louvered/Vented

Microperforated

Mix and Match Widths

### TEXTURE

Smooth

Wood Grain Embossed (.032 aluminum only)

### FINISH

70% PVDF, Mirrored, Wood Grain Finishes

### COLORS

Choice of over 40 stock colors in .032 aluminum

.019 and .024 aluminum available in Bone White with  
a 70% PVDF finish

Custom colors available\*

### ANODIZED

Clear Satin, Dark Bronze

### ACCESSORIES

Suspended carrier, a complete line of  
trims available

### CARRIER

Metal: Aluminum

Gauge: .040

Length: Standard 12'-0"

### FILLER STRIPS (OPTIONAL)

Available in .019 aluminum in Black or Bone White

\*Subject to minimum quantities and longer lead time.  
Inquire for availability.

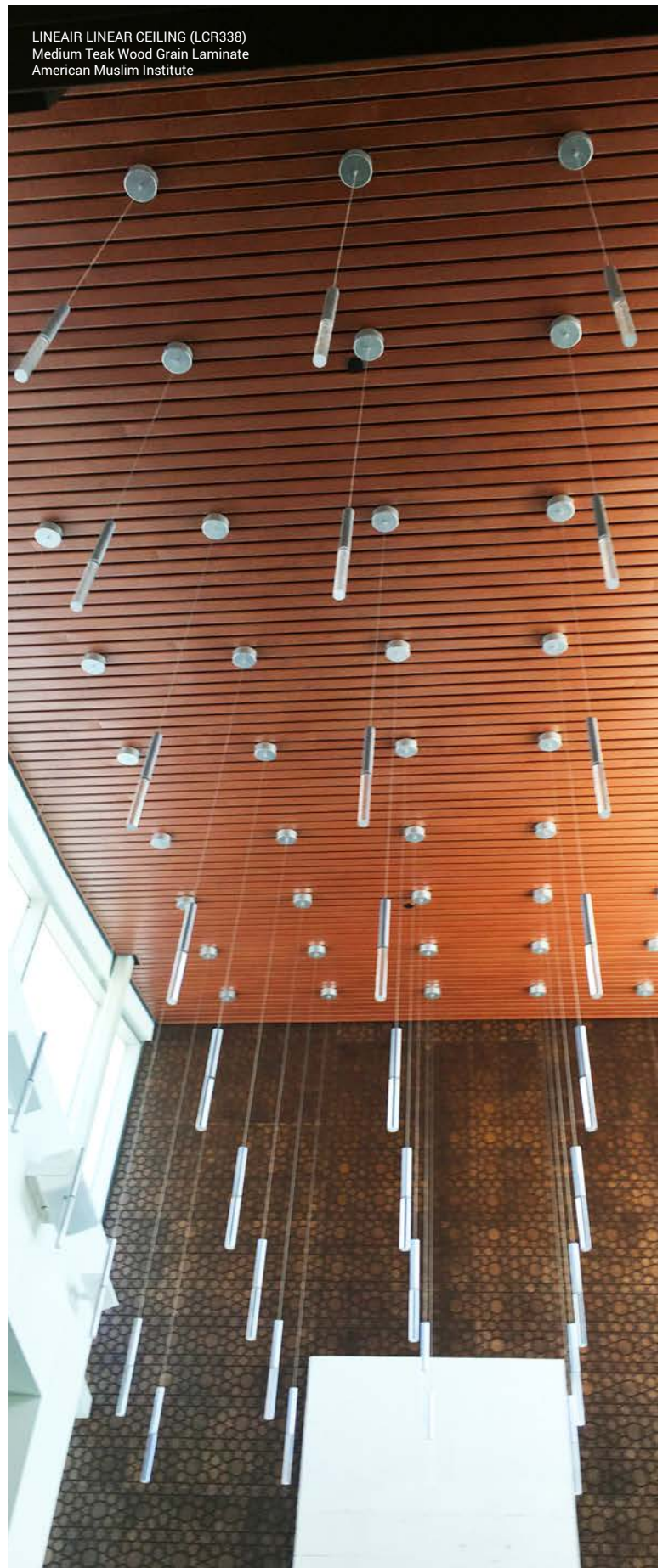

## LINEAIR LINEAR CEILING™ CONTINUED

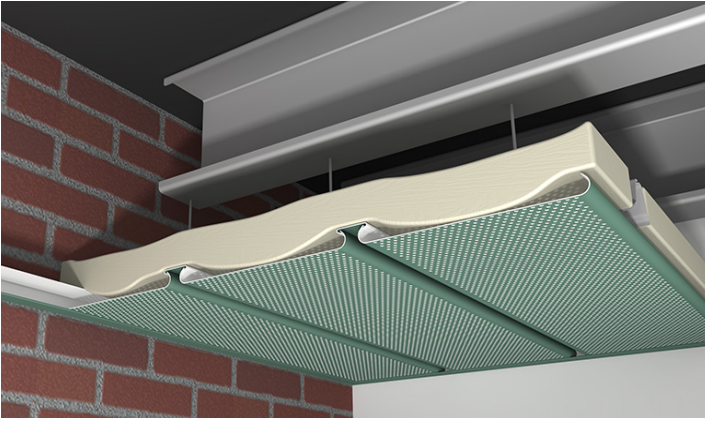

Microperforated LCR with recessed filler strip and insulation

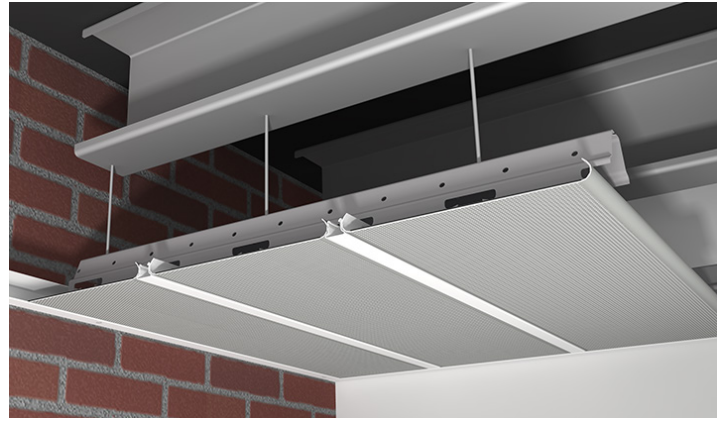

Microperforated LCR with flush filler strip with SOUNDTEX®

## MICROPERFORATED PANELS WITH SOUND ABSORPTION

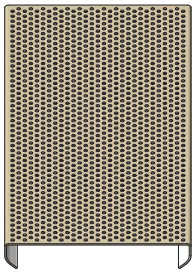

LCB338

.0625" Dia. x .125" Staggered Centers

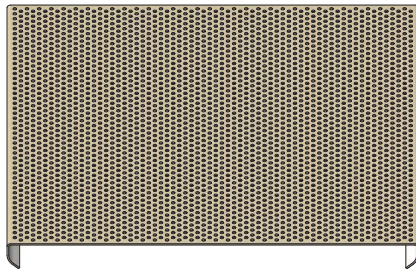

LCB738

.0625" Dia. x .125" Staggered Centers

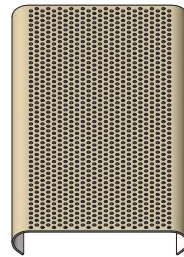

LCR338

.0625" Dia. x .125" Staggered Centers

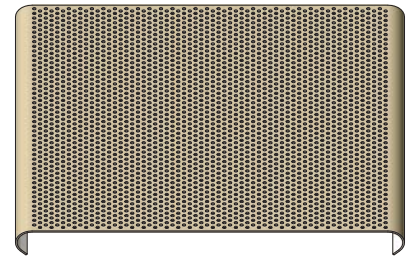

LCR738

.0625" Dia. x .125" Staggered Centers

## ACOUSTICAL SOUND PERFORMANCE: ASTM C423-17 & ASTM E795-16\*

SERIES/MODEL		LCR						
SAMPLE TYPE		3 <sup>3</sup> / <sub>8</sub> " CEILING PANELS WITH SOUNDTEX®						
MOUNTING TYPE		E400						
DATA FILE NO.	1/3 OCTAVE SOUND ABSORPTION COEFFICIENTS AT THE OCTAVE BRAND FREQUENCIES						NRC	SAA
	125	250	500	1000	2000	4000		
J8807.01D	0.66	0.80	0.48	0.56	0.68	0.57	0.65	0.65

SERIES/MODEL		LCR						
SAMPLE TYPE		7 <sup>3</sup> / <sub>8</sub> " CEILING PANELS WITH SOUNDTEX®						
MOUNTING TYPE		E400						
DATA FILE NO.	1/3 OCTAVE SOUND ABSORPTION COEFFICIENTS AT THE OCTAVE BRAND FREQUENCIES						NRC	SAA
	125	250	500	1000	2000	4000		
J8807.01C	0.69	0.85	0.52	0.59	0.71	0.55	0.65	0.68

SERIES/MODEL		LCR						
SAMPLE TYPE		3 <sup>3</sup> / <sub>8</sub> " CEILING PANELS WITH 2" CFAB CELLULOSE INSULATION						
MOUNTING TYPE		E400						
DATA FILE NO.	1/3 OCTAVE SOUND ABSORPTION COEFFICIENTS AT THE OCTAVE BRAND FREQUENCIES						NRC	SAA
	125	250	500	1000	2000	4000		
J2523.01C	0.83	1.02	0.97	1.01	0.95	0.96	1.00	1.00

SERIES/MODEL		LCR						
SAMPLE TYPE		7 <sup>3</sup> / <sub>8</sub> " CEILING PANELS WITH 2" CFAB CELLULOSE INSULATION						
MOUNTING TYPE		E400						
DATA FILE NO.	1/3 OCTAVE SOUND ABSORPTION COEFFICIENTS AT THE OCTAVE BRAND FREQUENCIES						NRC	SAA
	125	250	500	1000	2000	4000		
J2523.01D	0.81	1.03	0.98	1.01	0.95	0.96	1.00	1.00

\*See ASTM manual for details on acoustical performance test methods.

LINEAIR LINEAR CEILING (LCR738)  
Custom Wood Grain 2-Coat with Black recessed filler strips  
Moser School  
Photo Credit: Michael Petrocelli



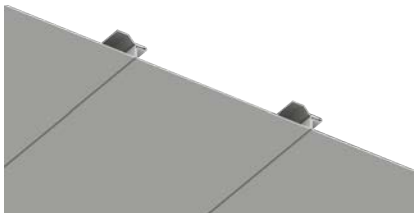

OPF



OPF with Microperforations

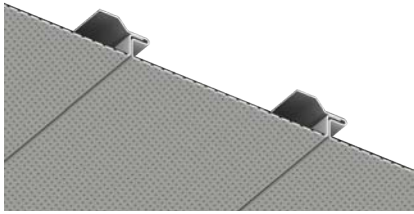

OPF with Microperforations & SOUNDTEX®

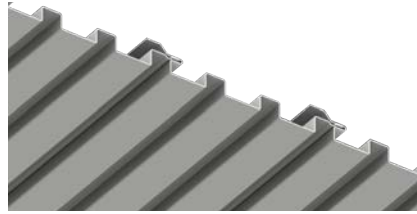

OPM



OPN

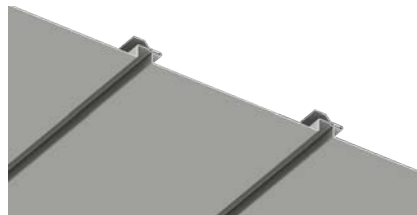

OPW

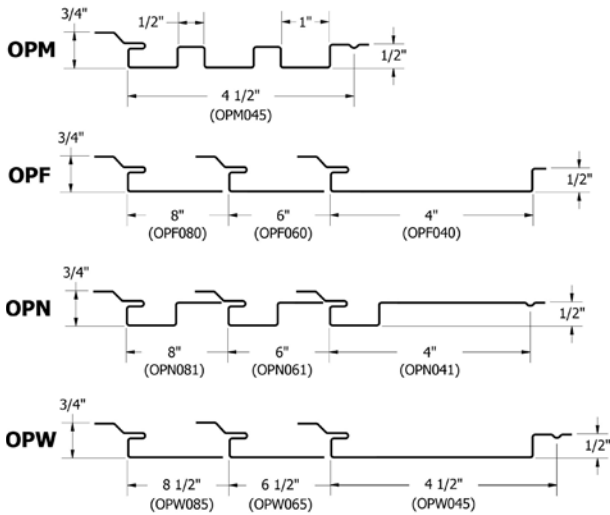

## LINEAIR OPALINE™

SKU: OPF, OPM, OPN, OPW

### MATERIAL

.032, .040 aluminum  
 24 ga. metallic coated steel

### PANEL SPECS

Coverage: OPF: 4", 6", 8"

OPM: 4 1/2"

OPN: 4", 6", 8"

OPW: 4 1/2", 6 1/2", 8 1/2"

Minimum Length: 1'-6"

Depth: 3/4"

### TEXTURE

Smooth, Stucco Embossed, or  
 Wood Grain Embossed

### FINISH

70% PVDF, Wood Grain Finishes

### COLORS

Choice of over 40 stock colors  
 Custom colors available\*

### CARRIER

Linear Opaline is available with  
 a suspended snap-in carrier or is  
 mechanically attached. Only OPF and  
 OPW may be installed with the snap-in  
 carrier.

\*Subject to minimum quantities and longer lead  
 time. Inquire for availability.



Flush Linear Opaline (OPF) Ceiling with Snap In Carrier



Reveal Linear Opaline (OPW) Ceiling with Snap In Carrier



Reveal Linear Opaline (OPW) Ceiling with Snap In Carrier Mechanically Attached to a Drywall Grid

## MICROPERFORATED PANELS WITH SOUND ABSORPTION

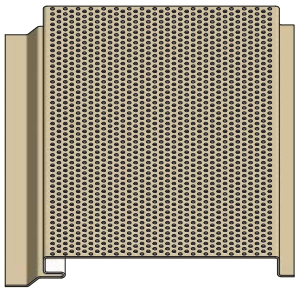

**OPF040**

.0625" Dia. x .125" Staggered Centers

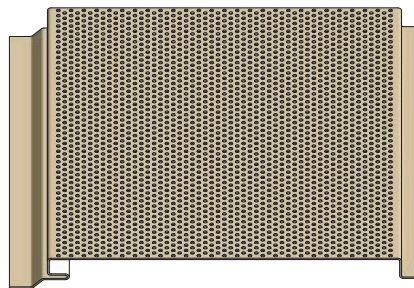

**OPF060**

.0625" Dia. x .125" Staggered Centers

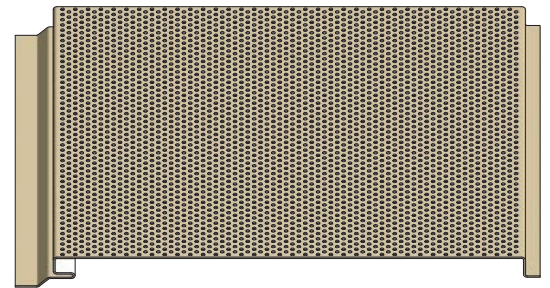

**OPF080**

.0625" Dia. x .125" Staggered Centers

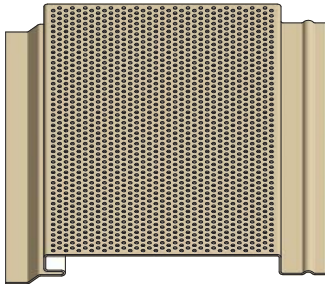

**OPW045**

.0625" Dia. x .125" Staggered Centers

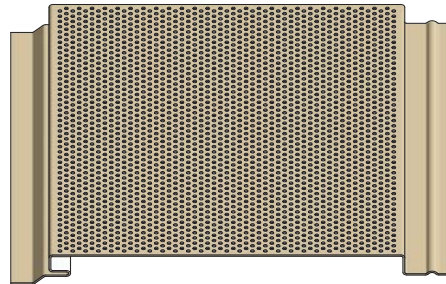

**OPW065**

.0625" Dia. x .125" Staggered Centers

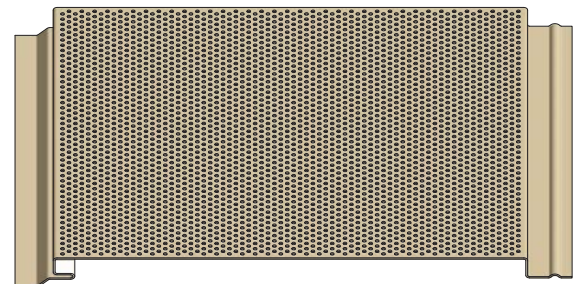

**OPW085**

.0625" Dia. x .125" Staggered Centers

## ACOUSTICAL SOUND PERFORMANCE: ASTM C423-17 & ASTM E795-16\*

<b>SERIES/MODEL</b>	OPW							
<b>SAMPLE TYPE</b>	6" CEILING PANELS WITH SOUNDTEX®							
<b>MOUNTING TYPE</b>	E400							
DATA FILE NO.	1/3 OCTAVE SOUND ABSORPTION COEFFICIENTS AT THE OCTAVE BRAND FREQUENCIES						NRC	SAA
	125	250	500	1000	2000	4000		
J2520.01A	0.78	0.90	0.56	0.61	0.66	0.70	0.70	0.70

<b>SERIES/MODEL</b>	OPW							
<b>SAMPLE TYPE</b>	6" CEILING PANELS WITH 2½" FIBERGLASS INSULATION							
<b>MOUNTING TYPE</b>	E400							
DATA FILE NO.	1/3 OCTAVE SOUND ABSORPTION COEFFICIENTS AT THE OCTAVE BRAND FREQUENCIES						NRC	SAA
	125	250	500	1000	2000	4000		
J2520.01B	0.92	1.04	0.97	0.98	0.91	0.87	1.00	0.99

\*See ASTM manual for details on acoustical performance test methods.



LINEAIR OPALINE  
55% Al-Zn Alloy Coated Steel With Acrylic Coated Steel  
American Metal Supply



# SPECIALTY CEILINGS

## LINEAIR TORSION SPRING SYSTEM

### PANEL SIZE

Inquire for material and panel coverage availability

### MATERIAL

Panels: .032, .040, .050, .063, & .080 aluminum  
T-Bar Suspension: .021 (standard) galvanized steel, .024 (heavy duty) galvanized steel

### COLORS

Choice of over 40 stock colors  
Custom colors and finishes available

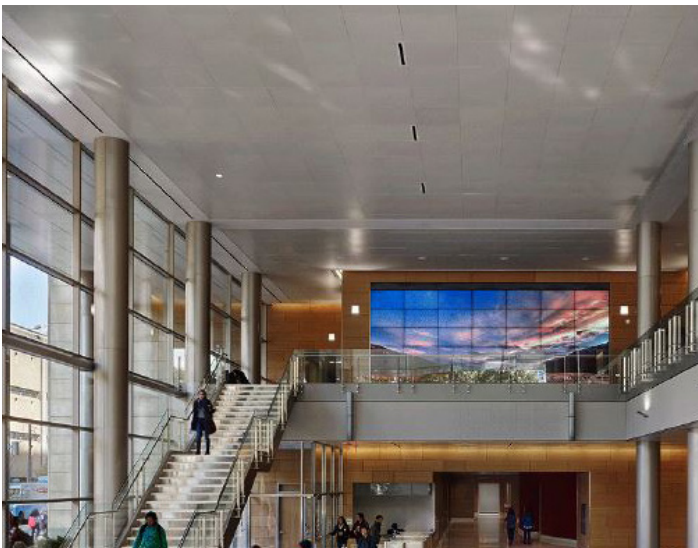
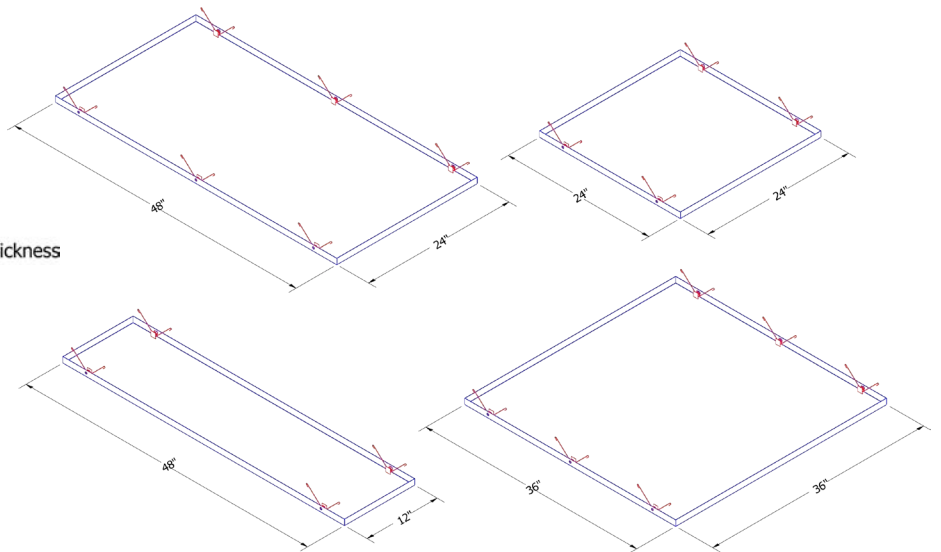
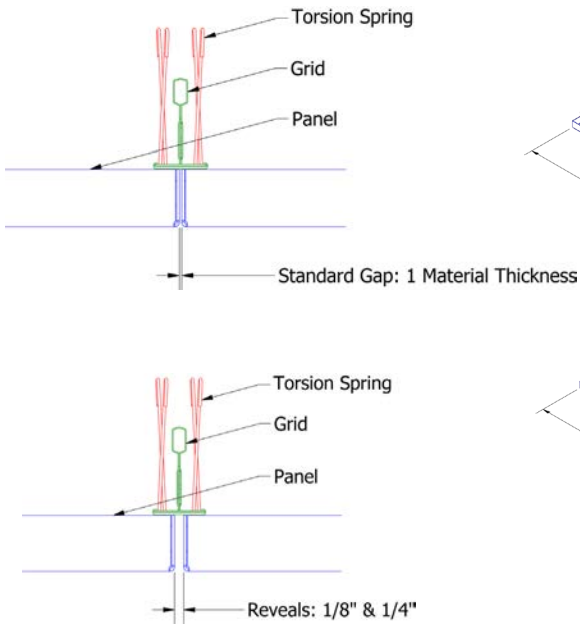

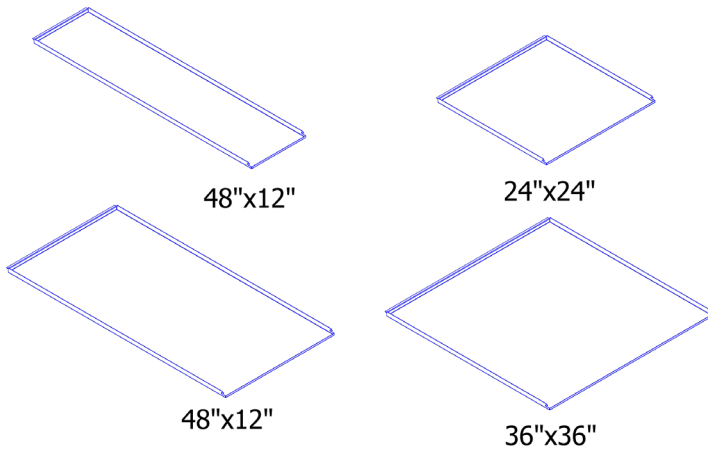

## LINEAR LIFT & SHIFT

### PANEL SIZE

Inquire for material and panel coverage availability

### MATERIAL

Panels: .032, .040, .050, .063, & .080 aluminum

### COLORS

Choice of over 40 stock colors  
Custom colors and finishes available

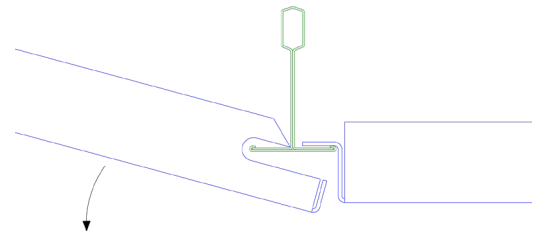
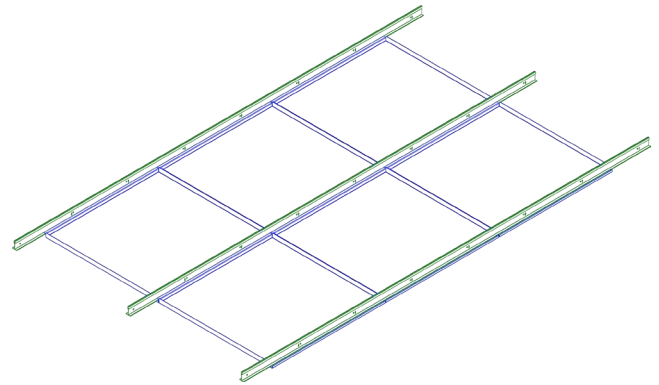
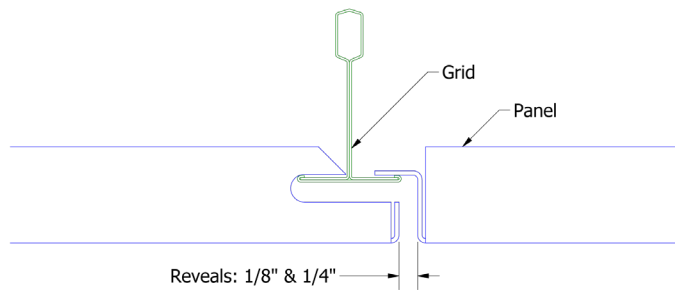
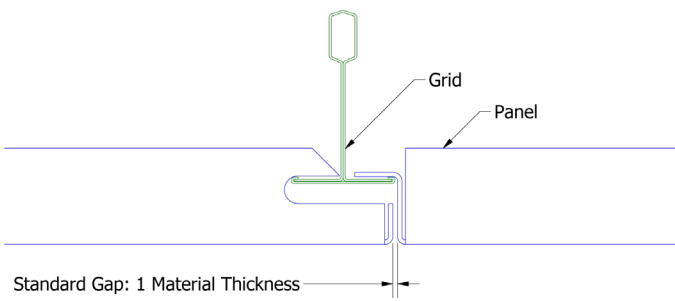

LINEAIR LINEAR CEILING  
Dark Teak  
Quadrant Information Security





## LINEAIR SUSPENDED EDGE STANDARD & RADIUSED TRIM SIZE

Face Size: 2", 4", 6", 8"

Custom: 1" increments to 24"

Standard length is 12" for straight sections

## MATERIAL

Panels: .032, .040, .050, .063, & .080 aluminum

## COLORS

Choice of over 40 stock colors

Custom colors and finishes available

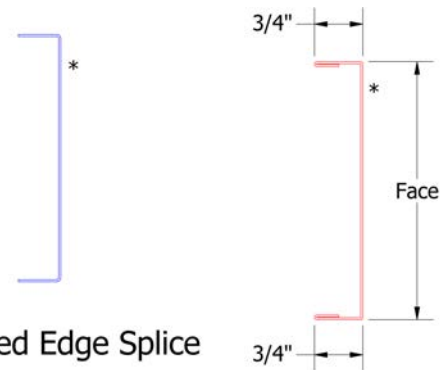
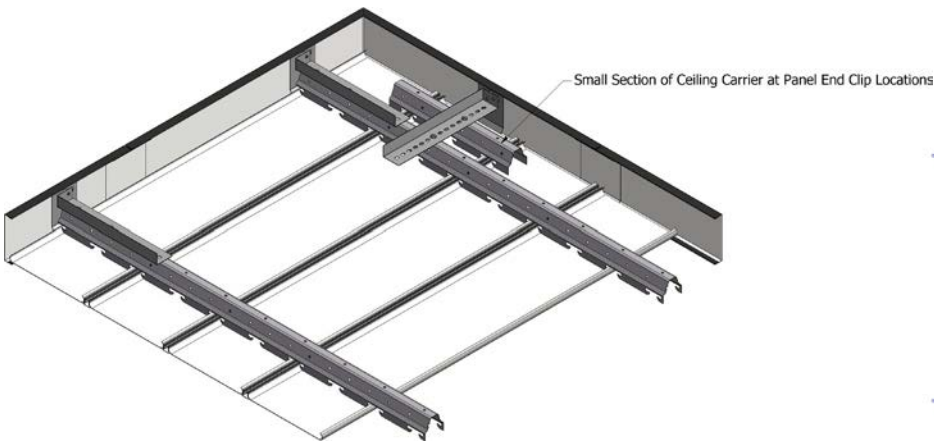

Suspended Edge Splice

Suspended Edge Trim

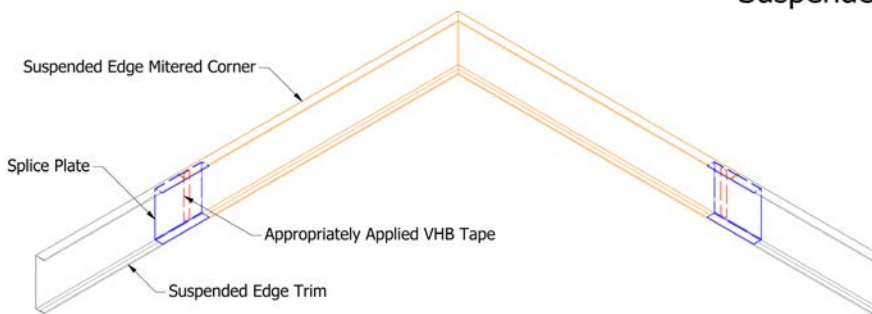

Note: \* denotes color side.

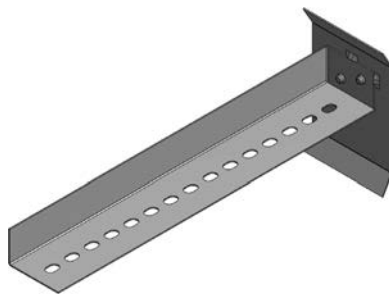

Suspended Edge Clip  
(20ga Steel)

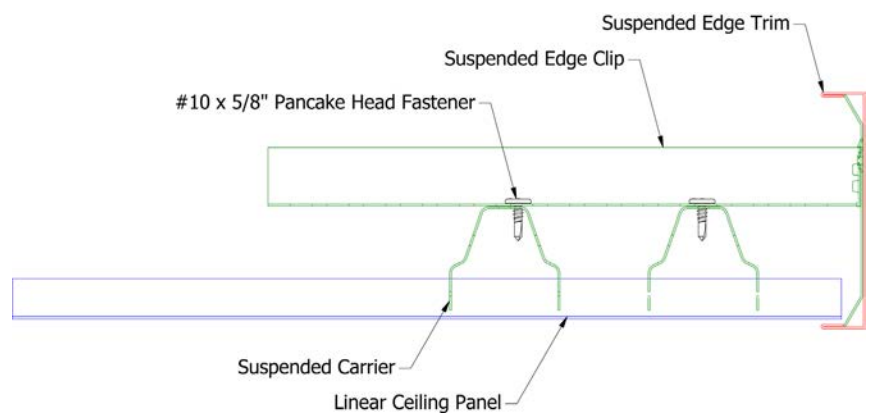

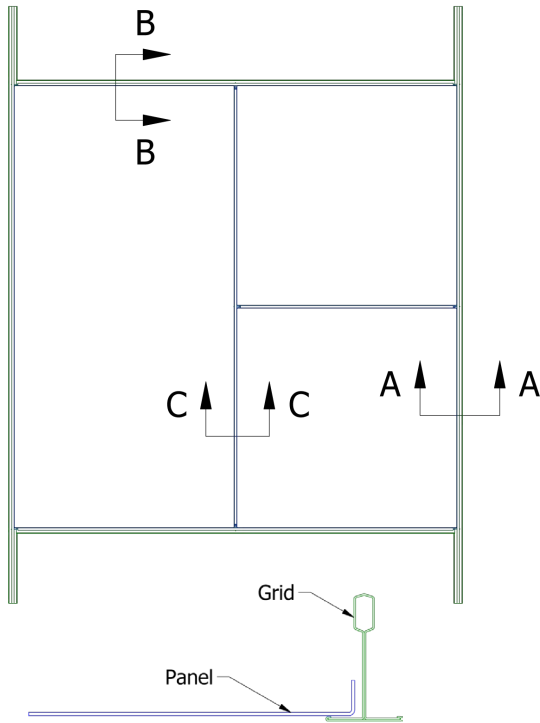

## LINEAIR METAL PANEL LAY-IN SYSTEM

### PANEL SIZE

Inquire for material and panel coverage availability

### MATERIAL

Panels: .032, .040, .050, .063, & .080 aluminum  
 T-Bar Suspension: .021 (standard) galvanized steel, .024 (heavy duty) galvanized steel

### COLORS

Choice of over 40 stock colors  
 Custom colors and finishes available

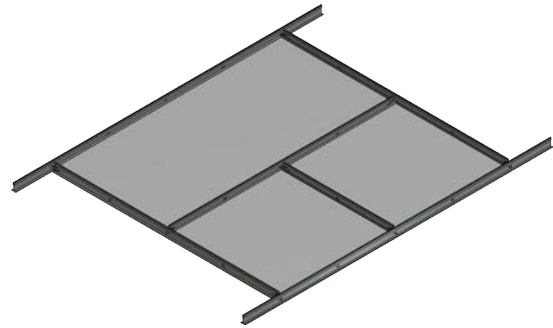

SECTION A-A

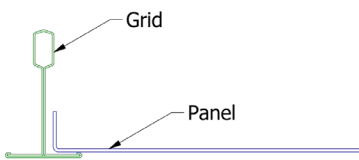

SECTION B-B

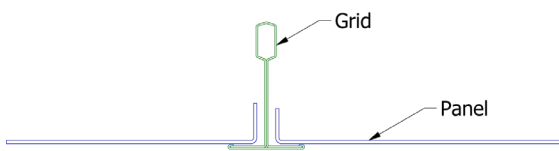

SECTION C-C

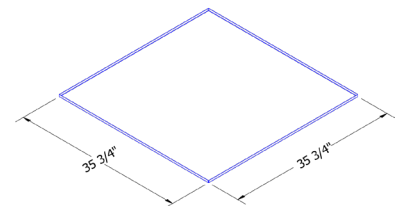
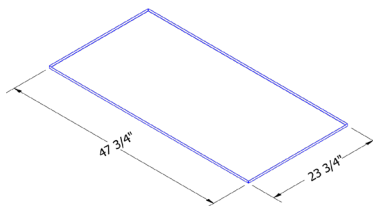
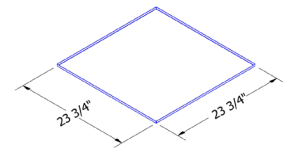
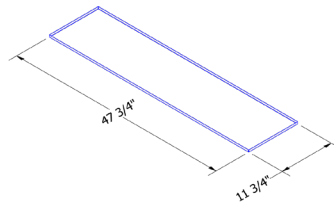



## LINEAIR PLANK

### PANEL SIZE

Inquire for material and panel coverage availability

### MATERIAL

Panels: .032, .040, .050, & .063 aluminum

### COLORS

Choice of over 40 stock colors

Custom colors and finishes available

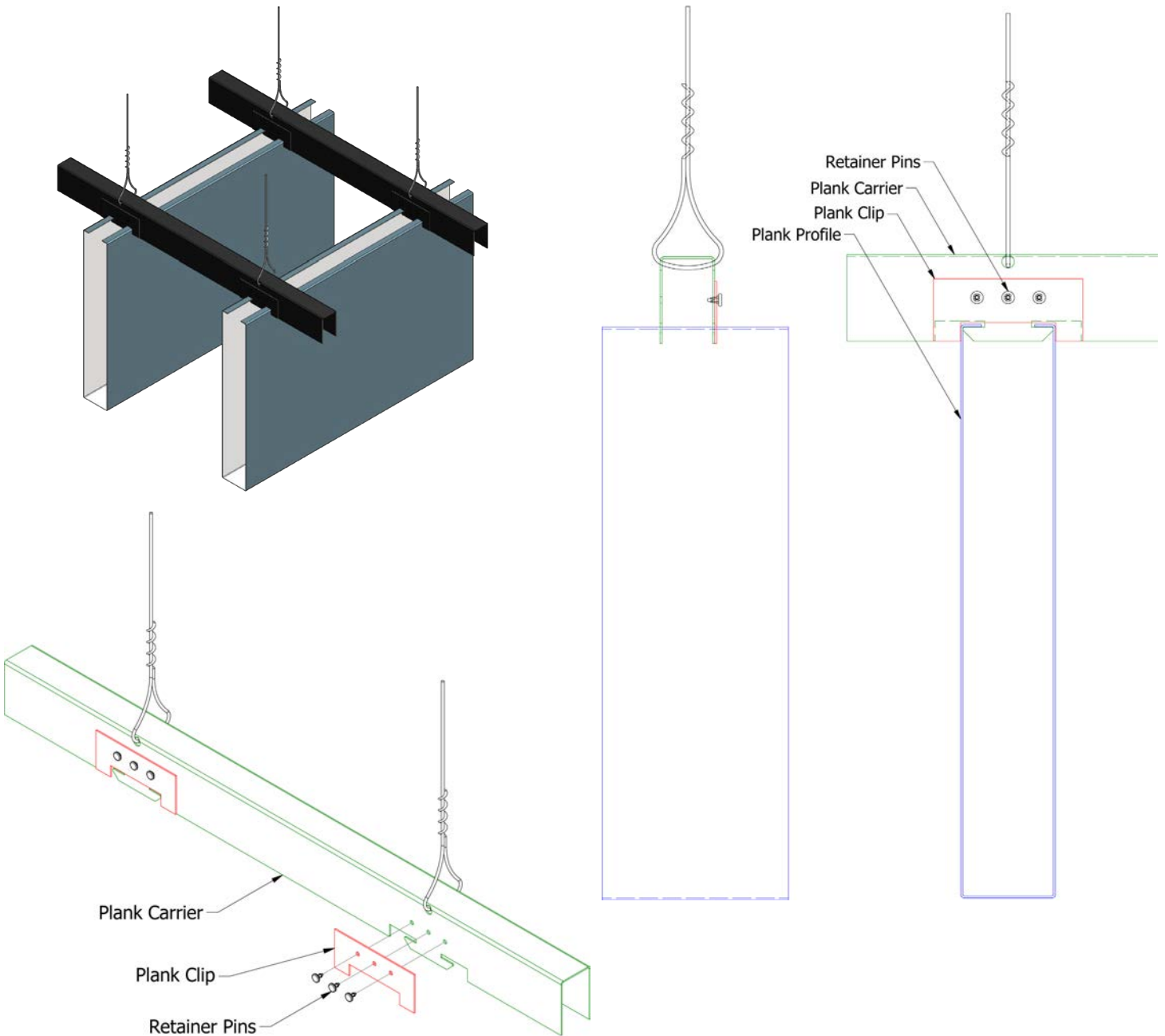



CASTLETOP  
Siam Blue, Regal Blue  
Silversmith & Bone White

LINEAIR LINEAR CEILING  
Custom Finish

Office, Allentown, PA

# COLOR CHART

## Stock Colors | 70% PVDF Finish



For additional color & finish offerings, visit [www.atas.com/colors](http://www.atas.com/colors). For current SRI values and agency listings refer to our Color and Reference Guide: [www.atas.com/sri](http://www.atas.com/sri).

## Matte Finish | 70% PVDF Finish



## Premium Colors | 70% PVDF Finish

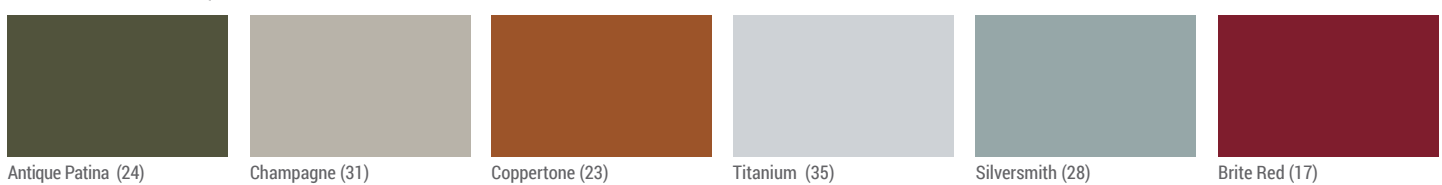

## Woodland Series | 70% PVDF Finish



## Oxide Series | 70% PVDF Finish

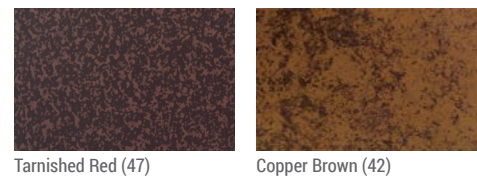

**ATAS International, Inc.**  
 Allentown, PA | Mesa, AZ | University Park, IL  
[www.atas.com](http://www.atas.com) | 800.468.1441



\*Subject to minimum quantities and extended lead time. Inquire for material and panel width availability. Wind-Lok® is a registered trademark of ATAS International, Inc. Colors are as close to the actual colors as modern printing allows. Exact color chips on request; this is a requirement for all premium colors. If you have requirements or preference for colors or finishes other than shown, contact ATAS. Color availability varies by material, gauge and profile. ATAS is not responsible for colors selected from color chart. ATAS reserves the right to modify, eliminate and/or change its products without prior notification. Contact ATAS for more information. Every project is different. To the full extent permissible by law, ATAS disclaims all warranties, express or implied, including, but not limited to, implied warranties of merchantability and fitness for a particular purpose. A qualified engineer, architect or contractor should review suitability of use. Please visit [www.atas.com](http://www.atas.com) for the most up-to-date information. © 2023 ATAS International, Inc. LRD1223 LAT930