

Note: * denotes color side.

REV. NO.		DATE		DESCRIPTION OF REVISION		BY	APP
DWG. NO.		DR		DATE		SH. SIZE	
		KRK		3/15/2024		B	
MATERIAL		APP		SCALE		X:X	

ATAS ATAS INTERNATIONAL, INC
 Allentown PA
 610-395-8445
 Mesa AZ
 480-558-7210

TITLE **Opaline Panel Detail**

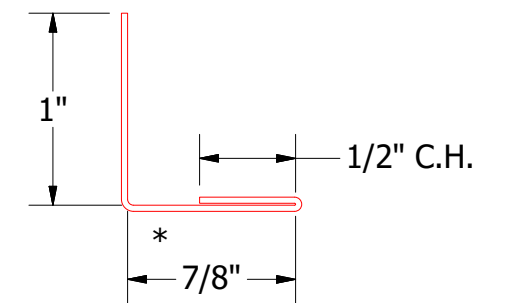
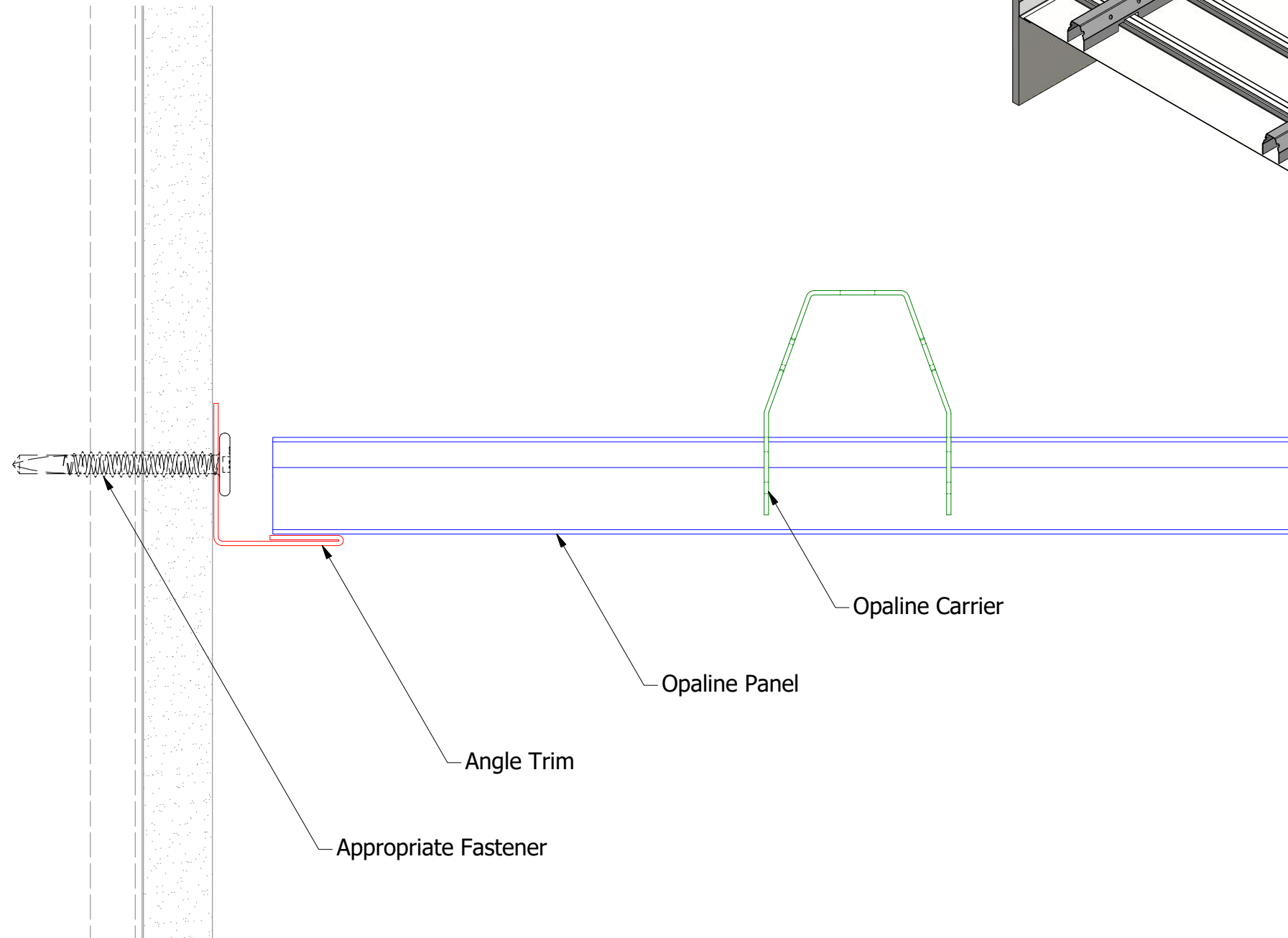
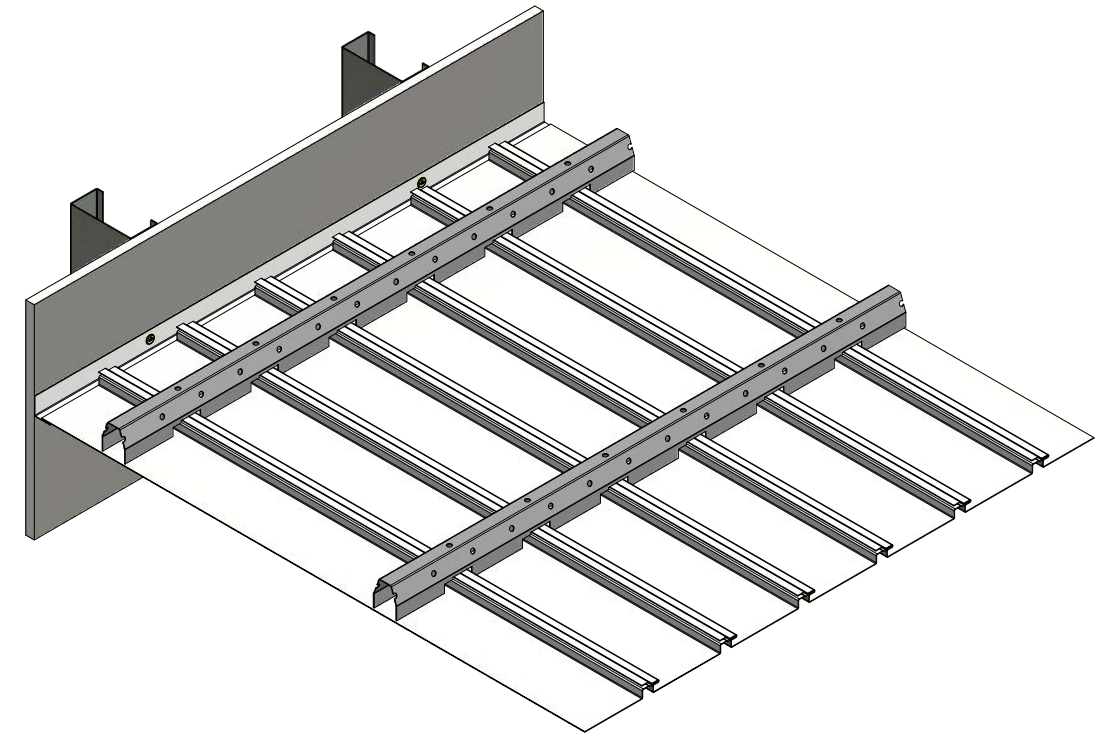

Angle Trim

Note: * denotes color side.



ATAS INTERNATIONAL, INC
 Allentown PA
 610-395-8445
 Mesa AZ
 480-558-7210

TITLE		Opaline Angle Trim Carrier Detail	
DWG. NO.	DR	DATE	10/2/2020
APP	DMR	DATE	
MATERIAL	SH. SIZE	SCALE	X:X
	B		

REV. NO.	DATE	DESCRIPTION OF REVISION	BY	APP
02	5/9/2023	Updated Substrate and Fastener	KRK	
01	3/18/2022	Updated Carrier Profile	KRK	

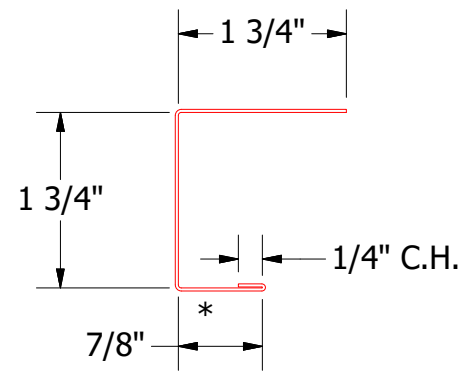
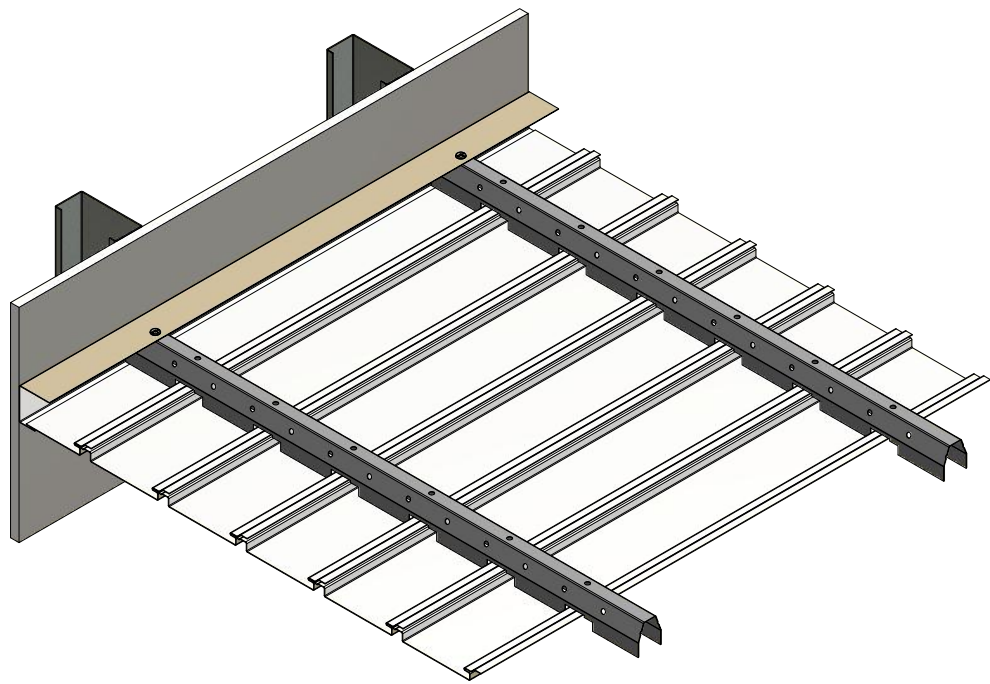

J Channel

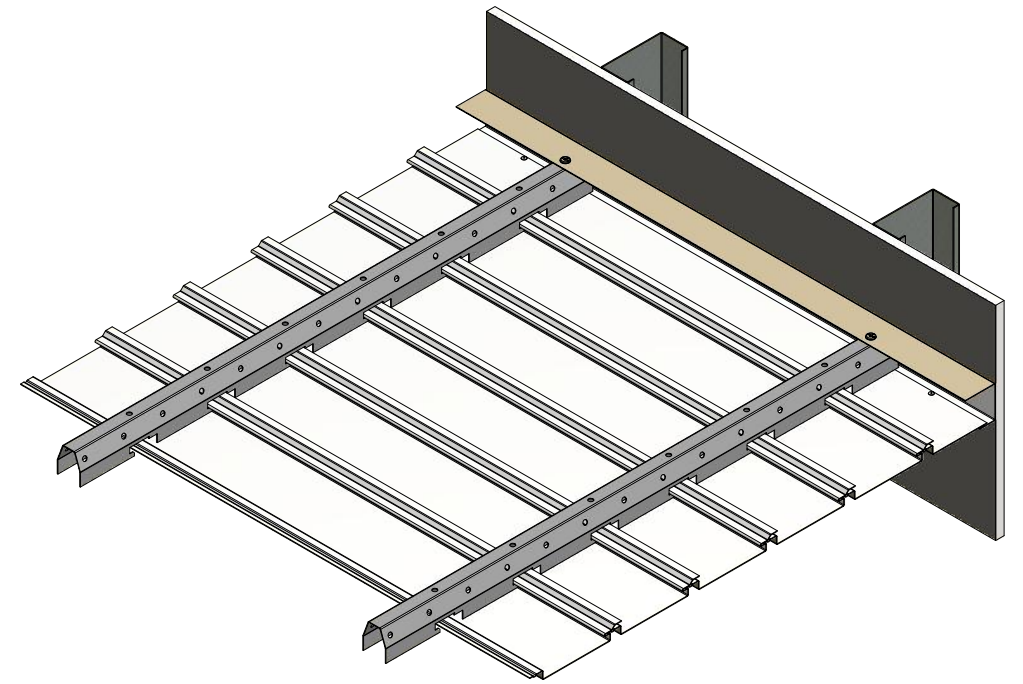

Starting Panel

Ending Panel

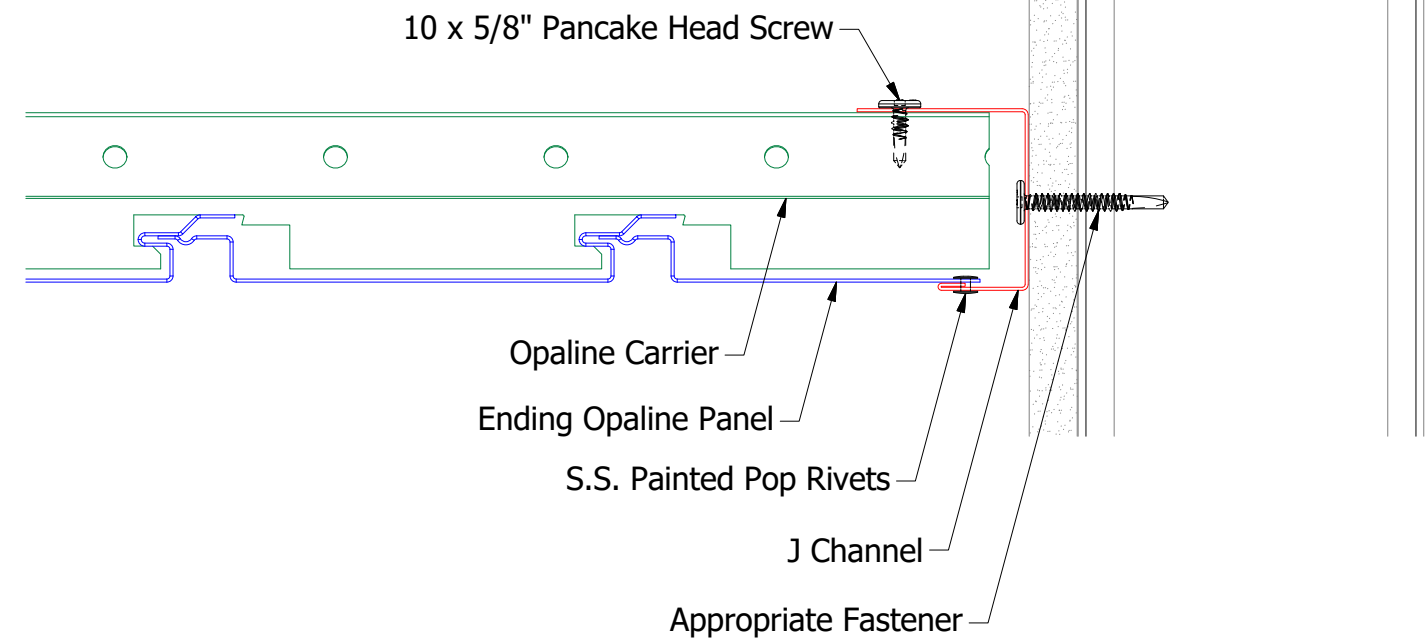
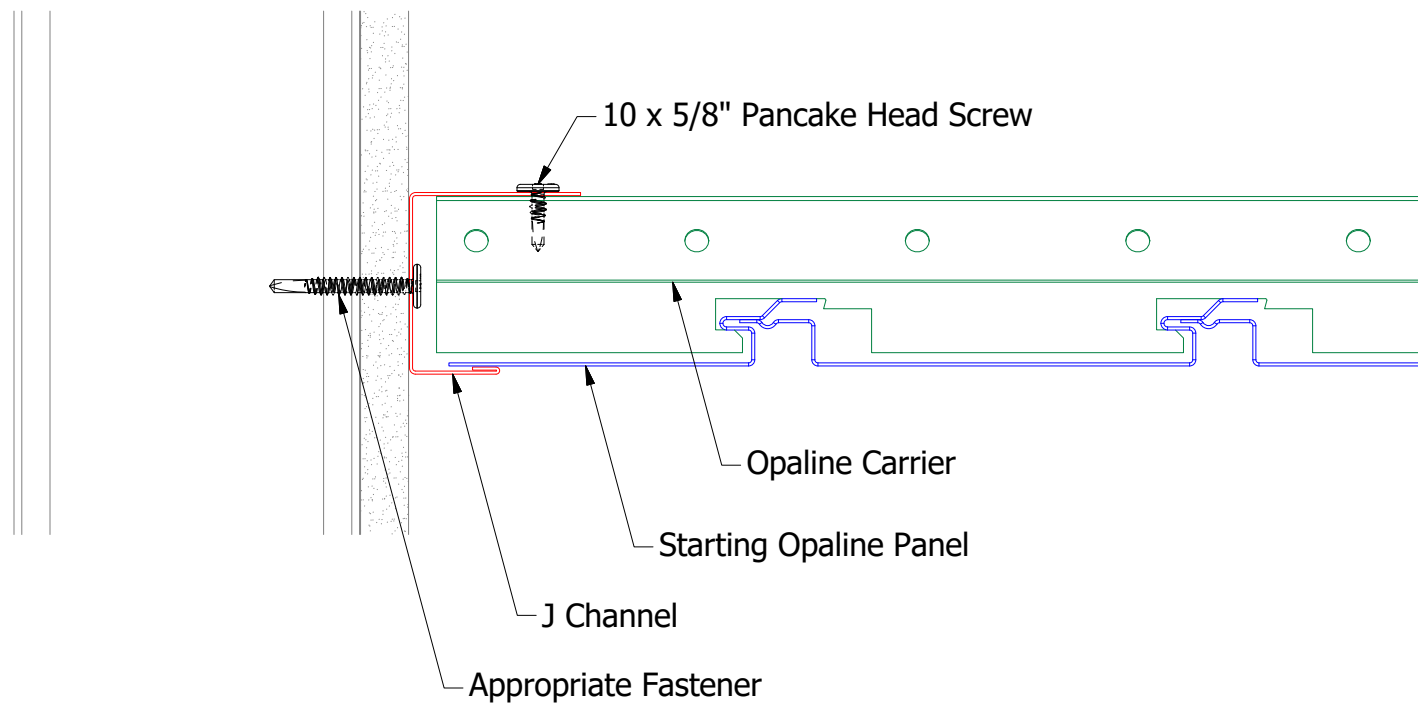

Note: * denotes color side.

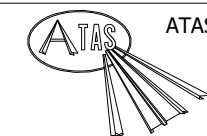

ATAS INTERNATIONAL, INC
 Allentown PA
 610-395-8445
 Mesa AZ
 480-558-7210

TITLE Opaline Carrier J Channel Detail

REV. NO.	DATE	DESCRIPTION OF REVISION	BY	APP	DWG. NO.	DR	DATE
						KRK	5/3/2023
					MATERIAL	APP	DATE
						SH. SIZE	SCALE
						B	X:X

VHB Tape on one side only for Expansion and Contraction

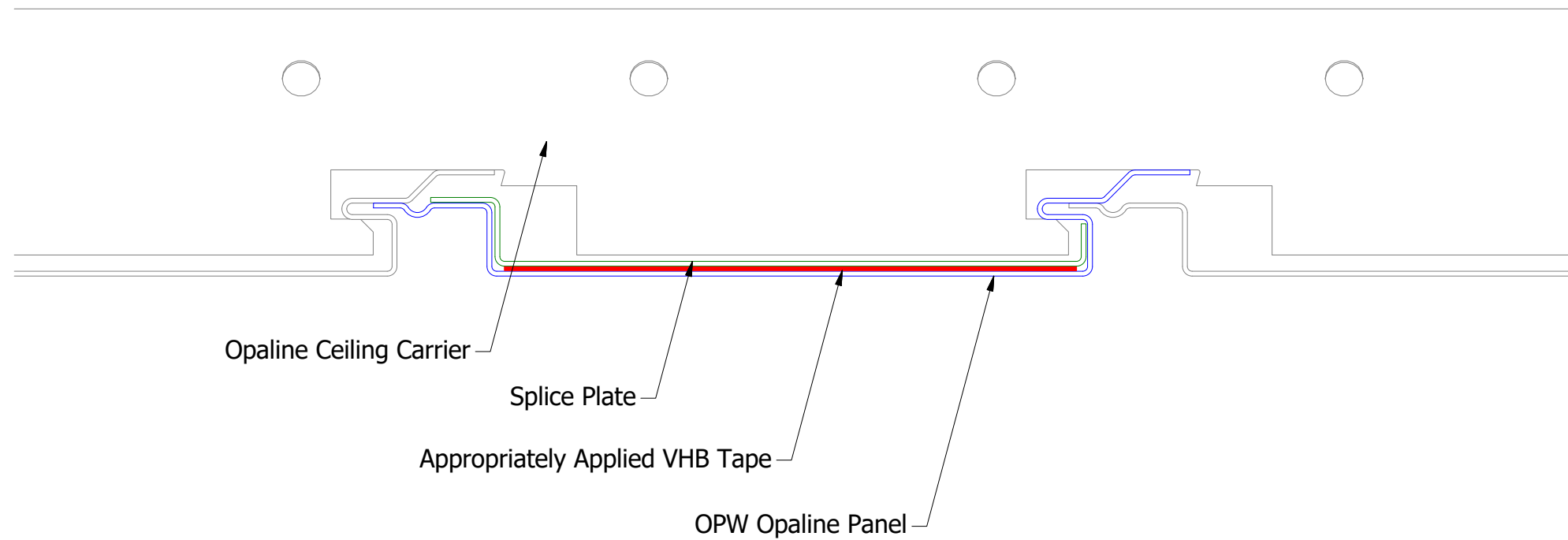
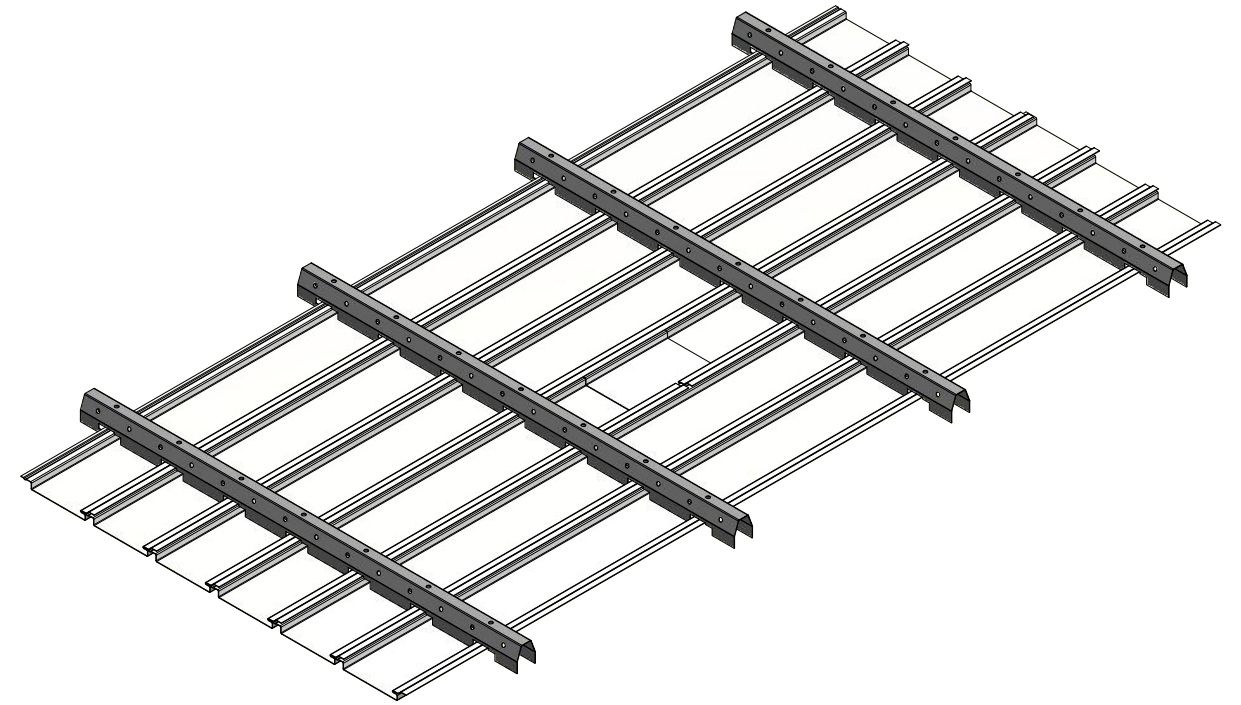
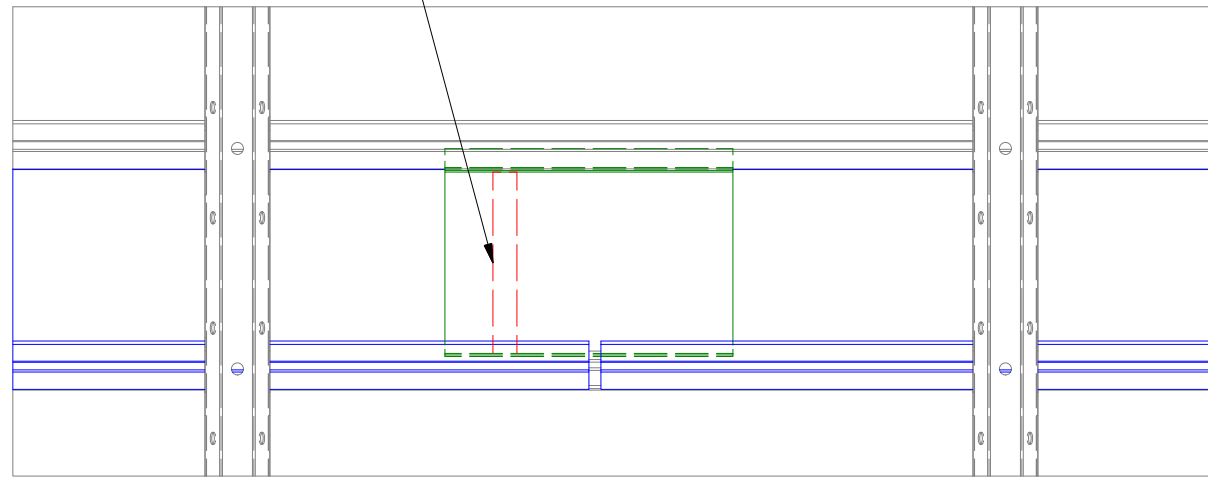

Note: 20'-0" Maximum Panel Lengths

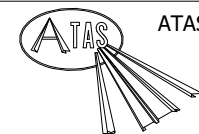

ATAS INTERNATIONAL, INC
 Allentown PA
 610-395-8445
 Mesa AZ
 480-558-7210

TITLE **Opaline Carrier Panel Splice Detail**

REV. NO.	DATE	DESCRIPTION OF REVISION	BY	APP	DWG. NO.	DR	DATE
						KRK	6/7/2022
					MATERIAL	APP	DATE
					SH. SIZE	B	SCALE
							X:X

Before securing Splice on both sides, ensure Carrier to Carrier spacing is right for correct panel engagement.

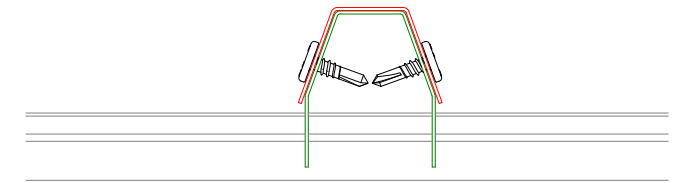
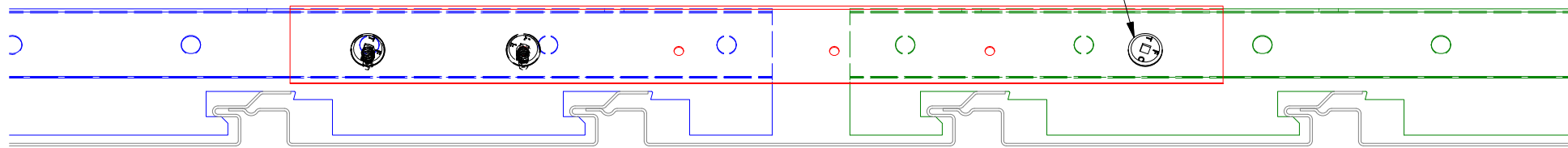

Stagger Splice Locations

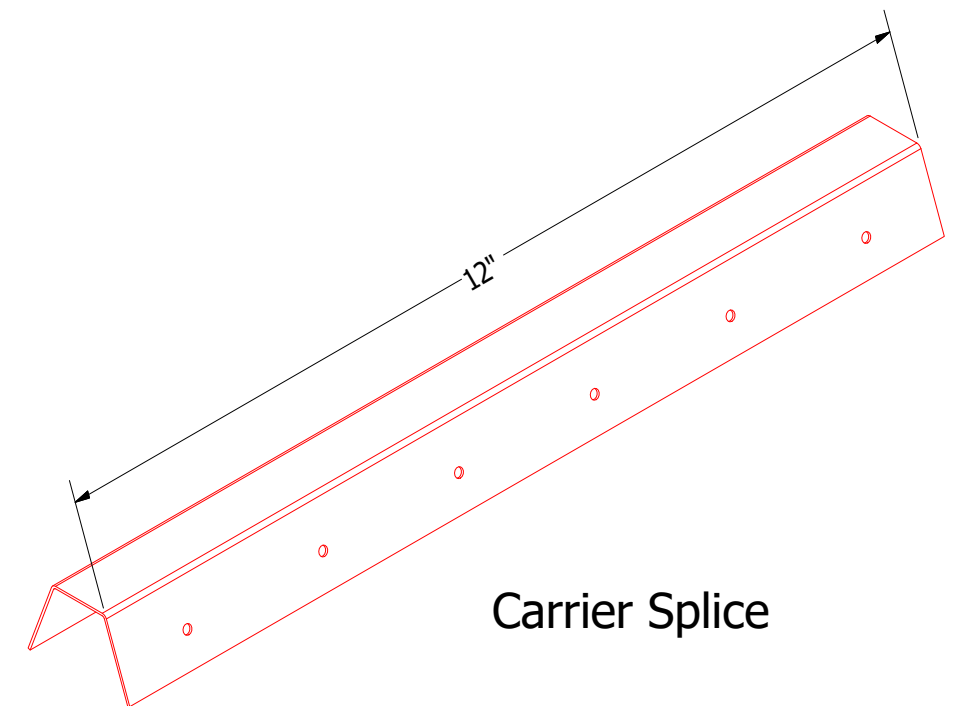
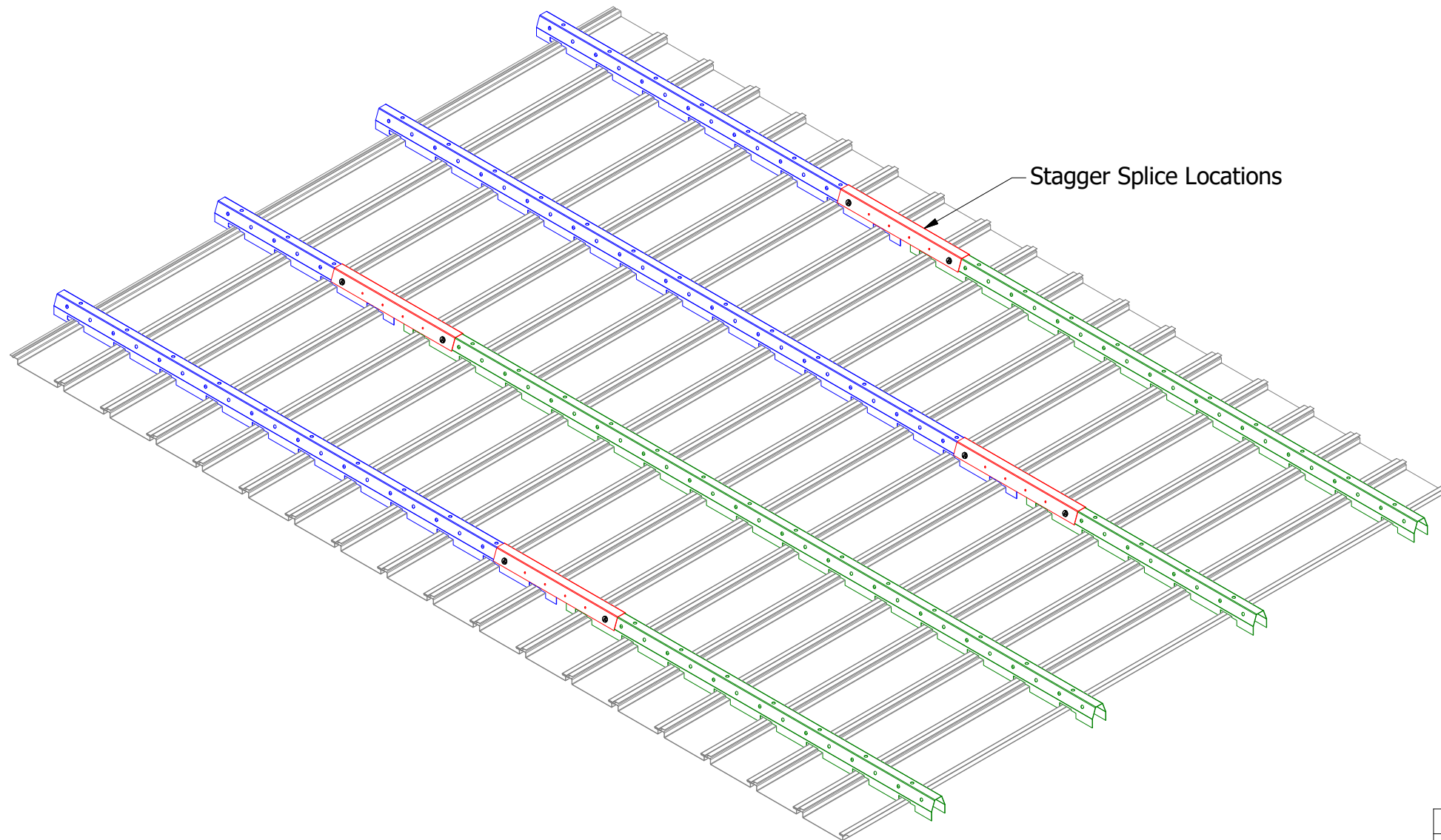

Carrier Splice

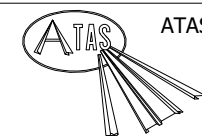

ATAS INTERNATIONAL, INC
 Allentown PA
 610-395-8445
 Mesa AZ
 480-558-7210

				TITLE Opaline Carrier Splice Option 1 Detail	
				DWG. NO.	DR KRK DATE 9/15/2023
01	3/15/2024	Updated Splice Installation Instructions	KRK	APP	DATE
REV. NO.	DATE	DESCRIPTION OF REVISION	BY	APP	SH. SIZE B SCALE X:X

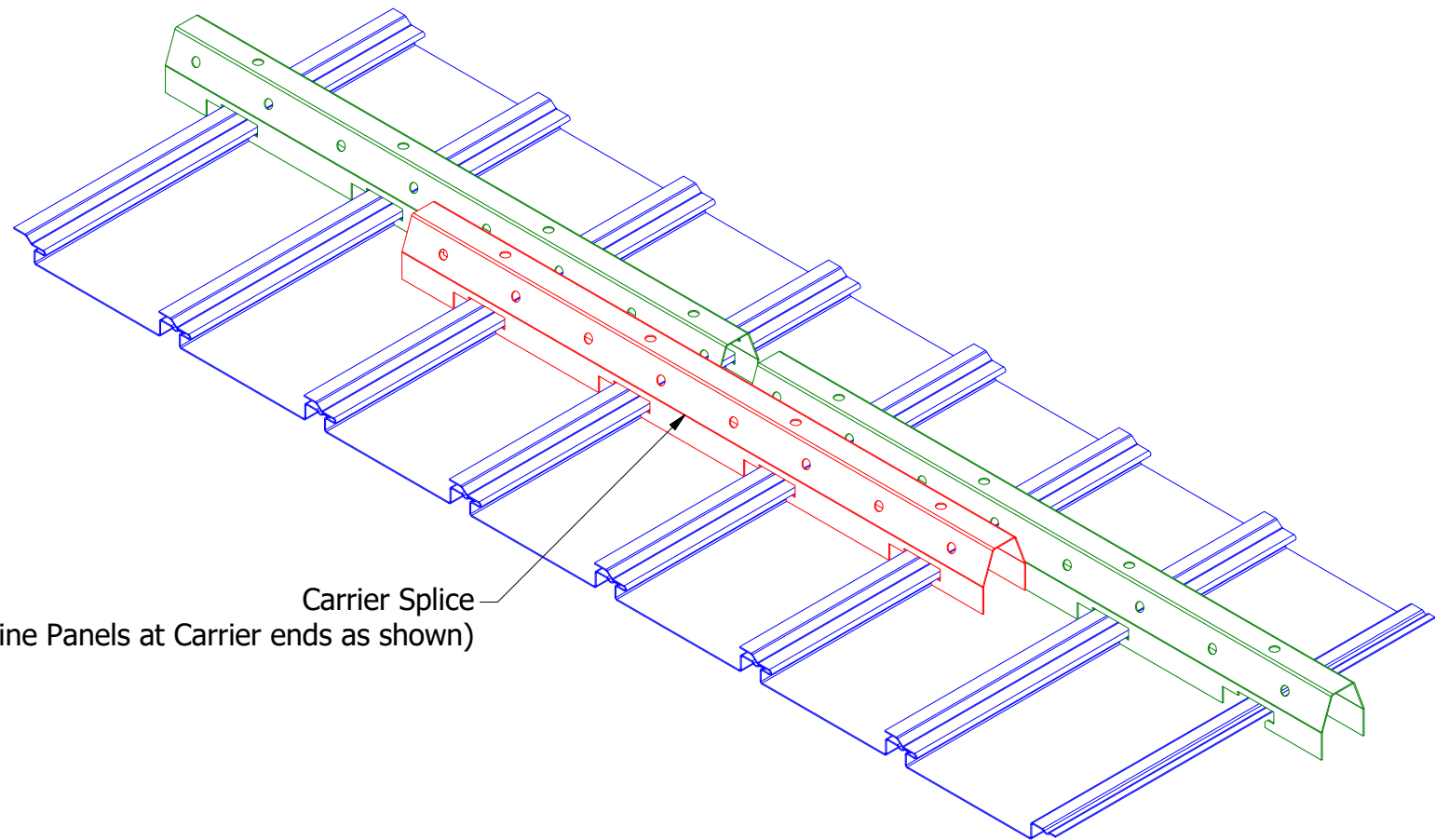

Carrier Splice
 (install on Opaline Panels at Carrier ends as shown)

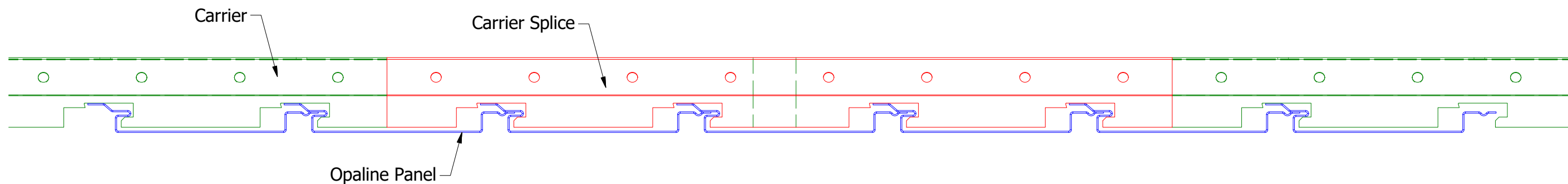

Carrier

Carrier Splice

Opaline Panel



ATAS INTERNATIONAL, INC
 Allentown PA
 610-395-8445
 Mesa AZ
 480-558-7210

TITLE
Opaline Carrier Splice Option 2 Detail

REV. NO.	DATE	DESCRIPTION OF REVISION	BY	APP	DWG. NO.	DR KRK	DATE 11/1/2021
					MATERIAL	APP	DATE
					SH. SIZE	B	SCALE X:X

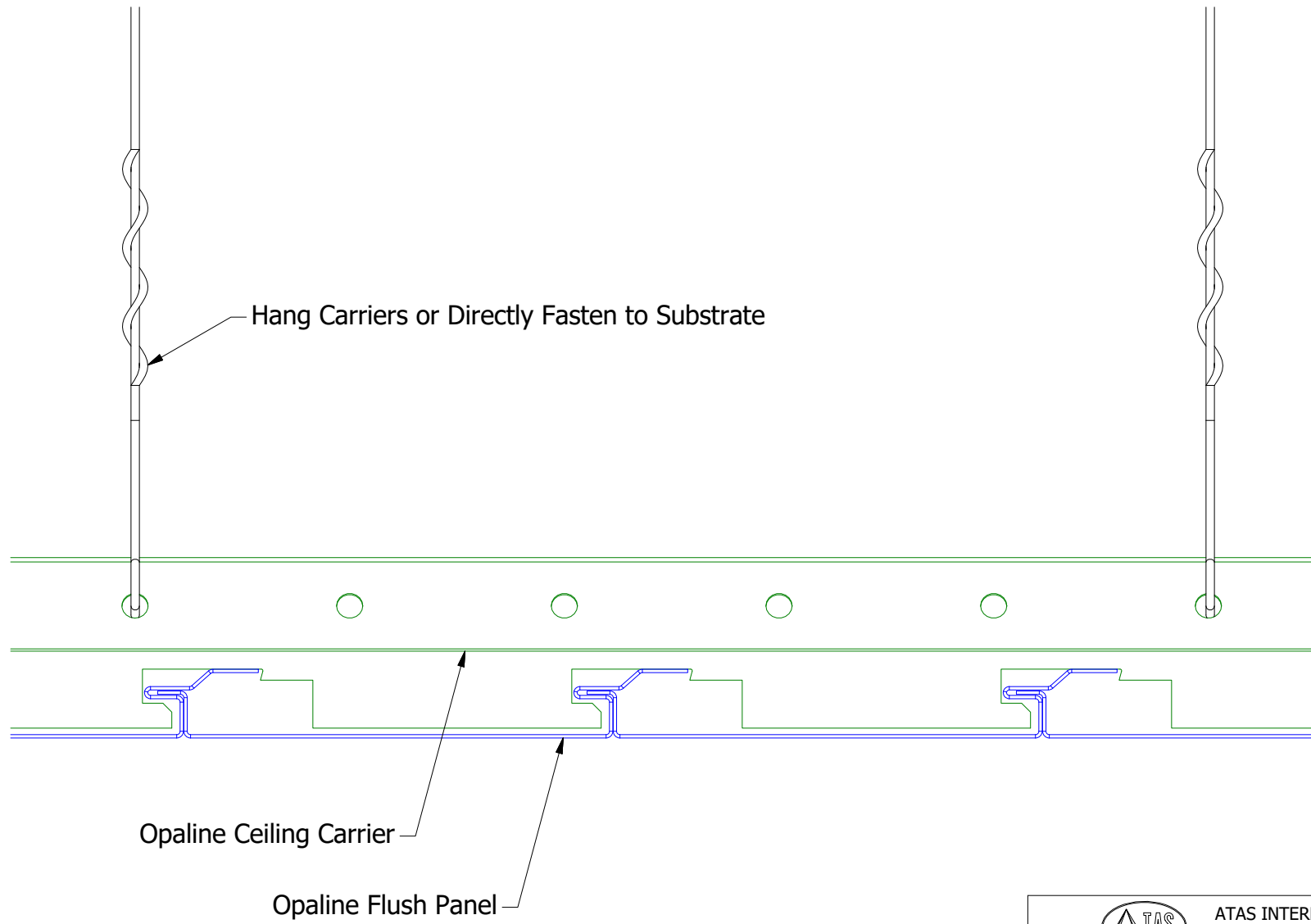

ATAS INTERNATIONAL, INC
 Allentown PA
 610-395-8445
 Mesa AZ
 480-558-7210

TITLE		Opaline Flush Panel and Carrier Profile Detail	
DWG. NO.	DR	APP	DATE
	KRK		3/27/2020
MATERIAL	SH. SIZE	SCALE	
	A	X:X	

REV. NO.	DATE	DESCRIPTION OF REVISION	BY	APP
01	4/29/2022	Updated Carrier Profile	KRK	

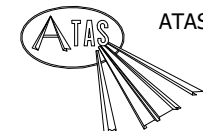
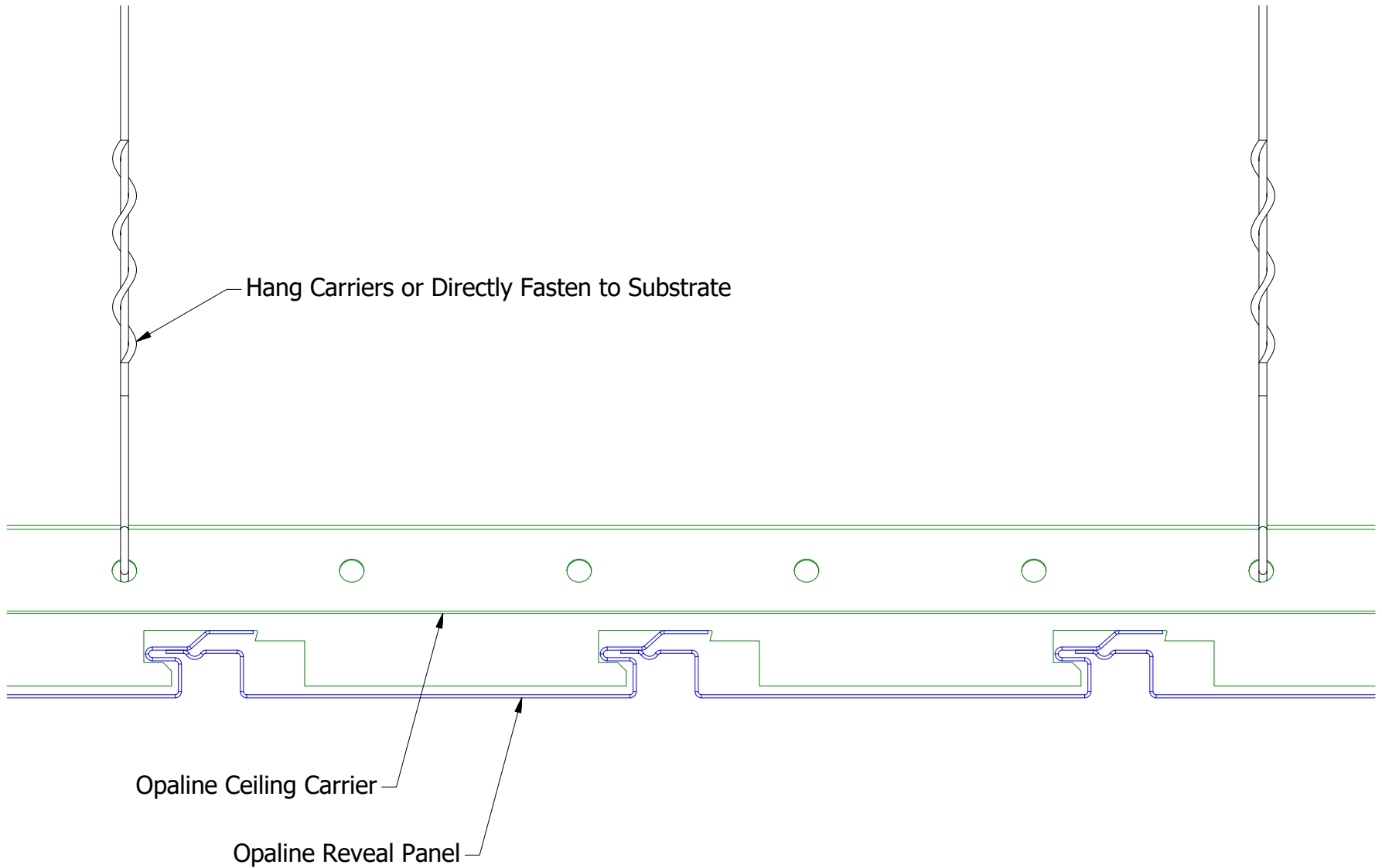

ATAS INTERNATIONAL, INC
 Allentown PA
 610-395-8445
 Mesa AZ
 480-558-7210

				TITLE		Opaline Reveal Panel and Carrier Profile Detail	
				DWG. NO.		DR	DATE
						KRK	3/30/2020
				MATERIAL		APP	DATE
01	4/29/2022	Updated Carrier Profile	KRK				
REV. NO.	DATE	DESCRIPTION OF REVISION	BY	APP	SH. SIZE	A	SCALE
						X:X	

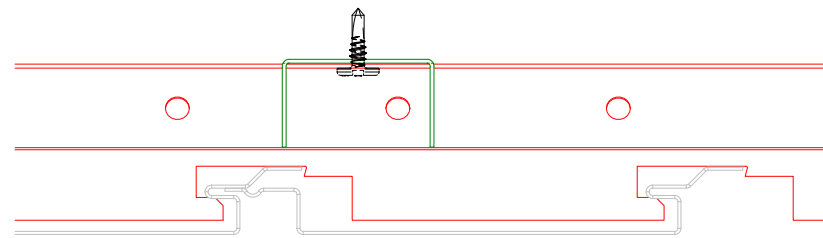

Section A-A

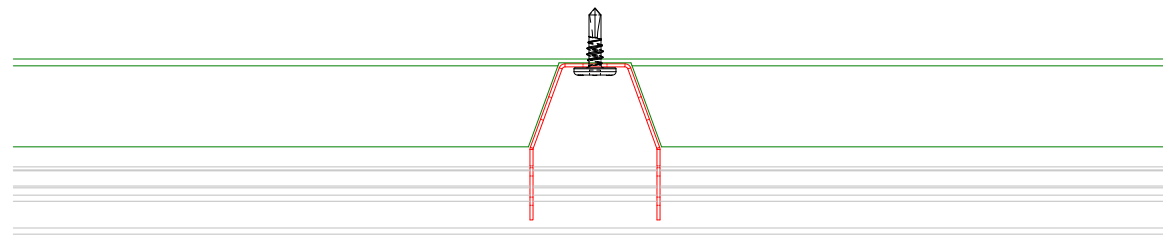

Section B-B

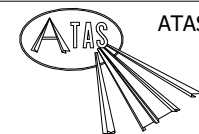
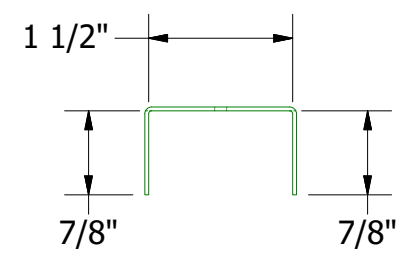
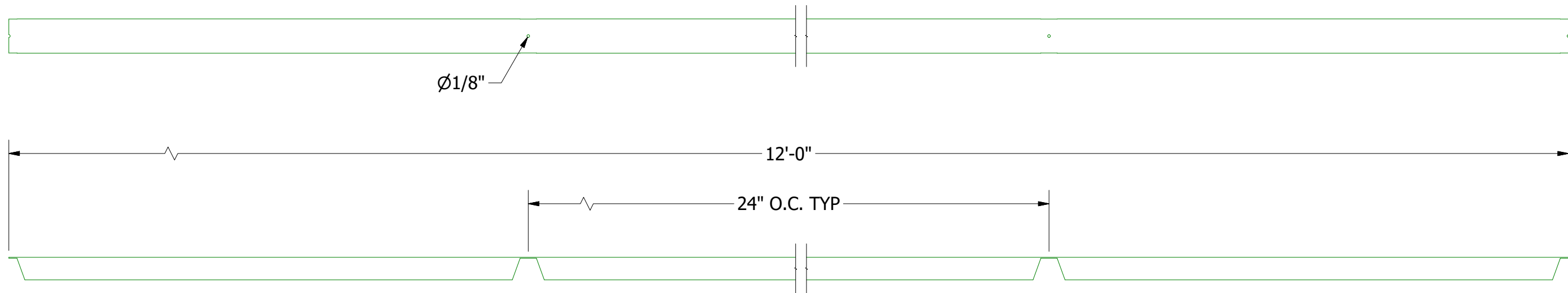
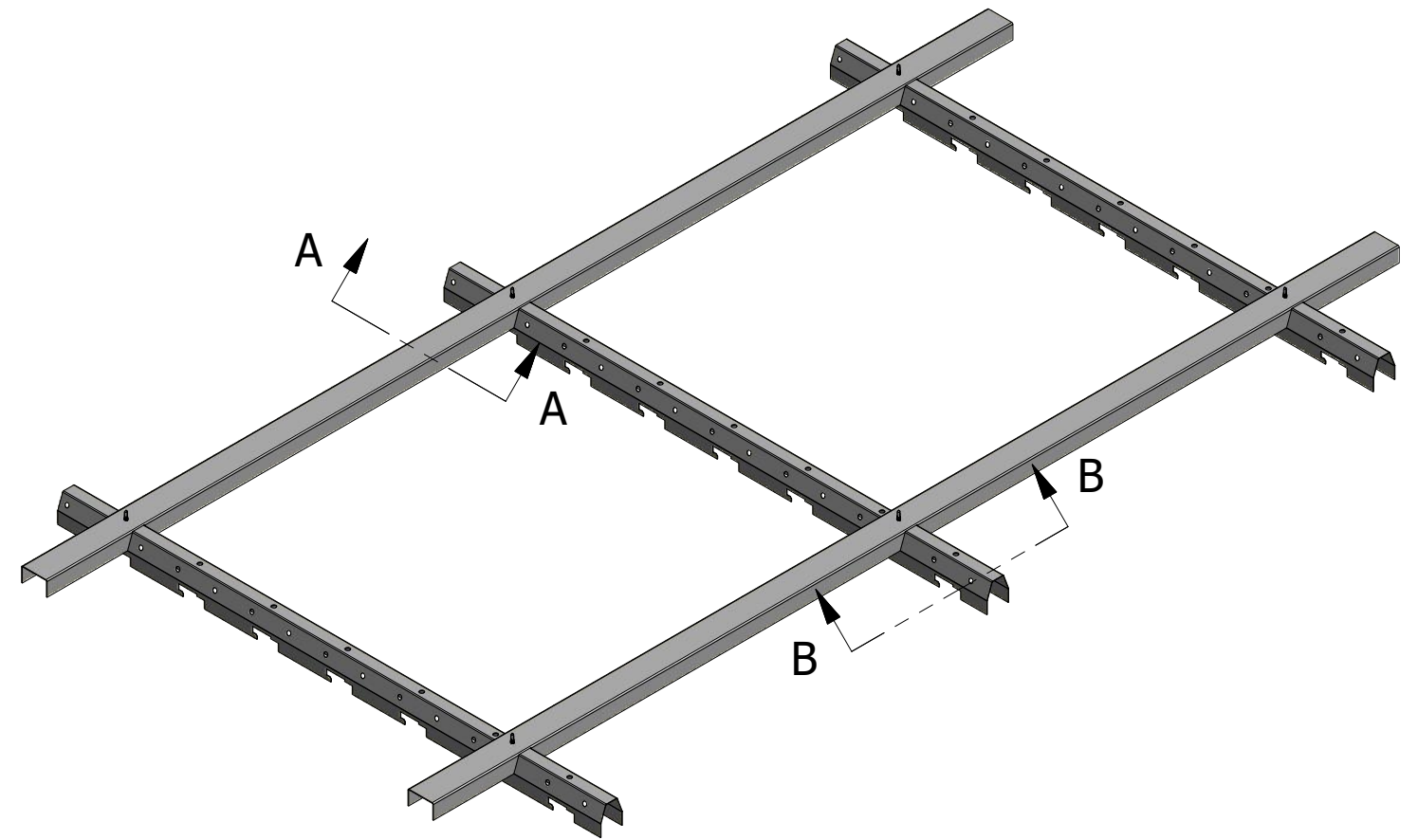

ATAS INTERNATIONAL, INC
 Allentown PA
 610-395-8445
 Mesa AZ
 480-558-7210

TITLE
Opaline Cross Carrier Spacer Detail

REV. NO.	DATE	DESCRIPTION OF REVISION	BY	APP	DWG. NO.	DR	DATE
						KRK	5/10/2023
					MATERIAL	APP	DATE
					SH. SIZE	B	SCALE
							X:X