

- Optional 18ga Support Plate
- Inside Corner Post
- 10 x 5/8" Pancake Head Fastener
- Design Wall Reveal Panel
- Appropriate Fastener
- U Girt
- Water Resistant Insulation
- Water and Air Resistive Barrier

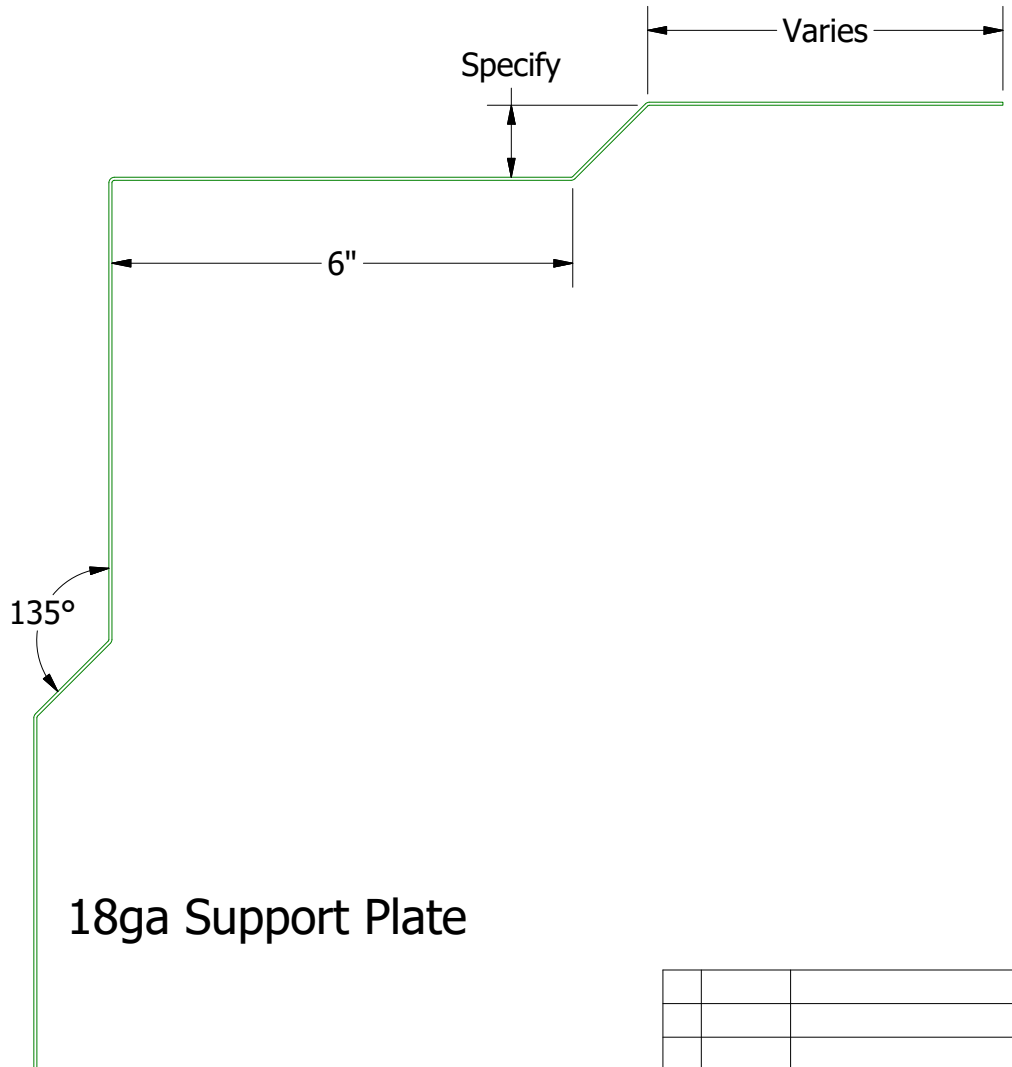

18ga Support Plate

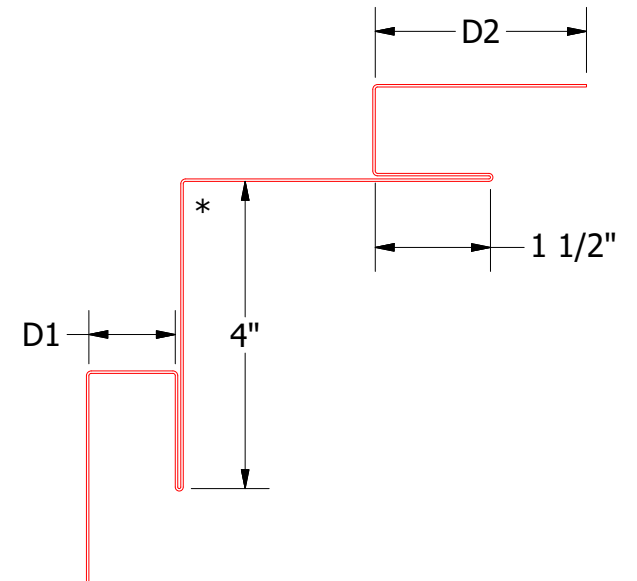
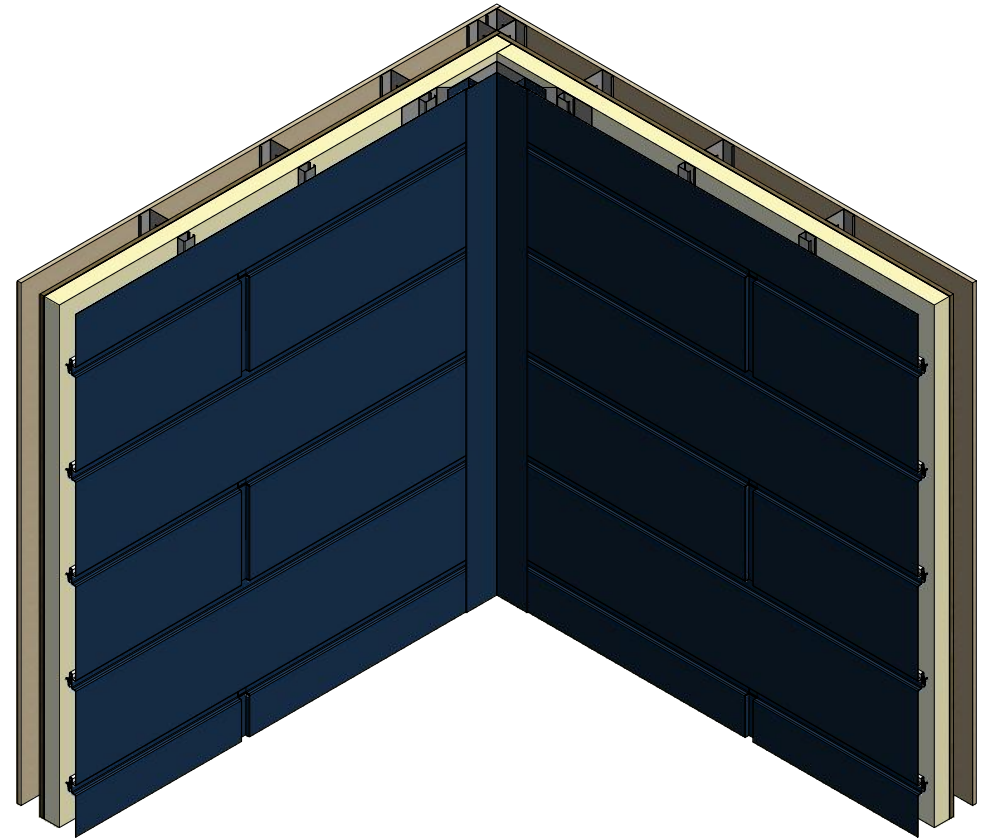

Inside Corner Post
 DWA601: D1 = 1 1/8", D2 = 2 3/4"
 DSA601: D1 = 1 7/8", D2 = 3"

Note: * denotes color side.
 Note: Optional 18ga Support Plate Available.

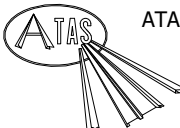
 ATAS INTERNATIONAL, INC Allentown PA 610-395-8445 Mesa AZ 480-558-7210		TITLE Design Wall Reveal Open Inside Corner Horizontal Detail	
		DWG. NO.	DR
		KRK	8/9/2022
		APP	DATE
		SH. SIZE	SCALE
		B	X:X

REV. NO.	DATE	DESCRIPTION OF REVISION	BY	APP