

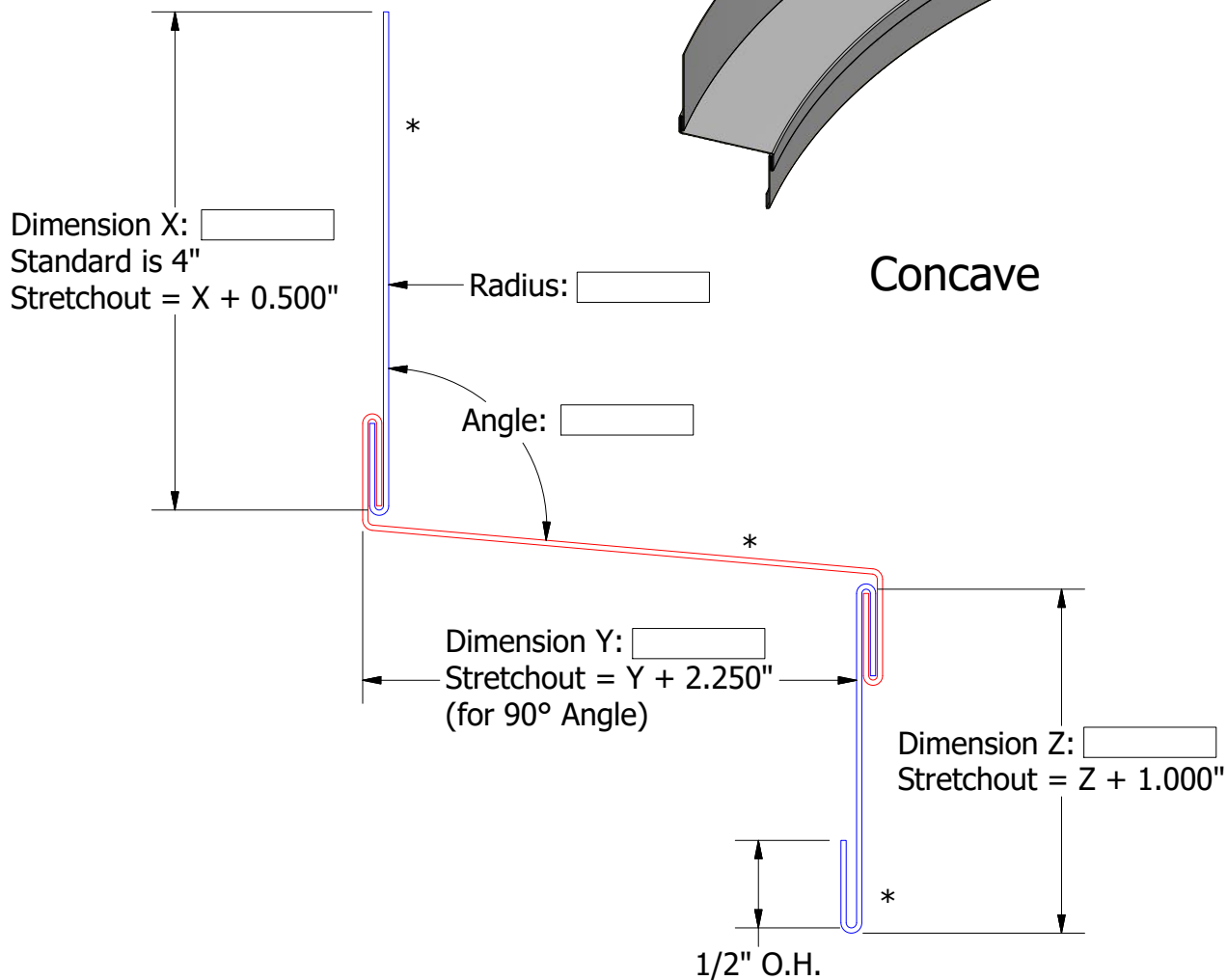

Concave

Convex



Order #

Concave: 

Convex: 

Material

Alum 24 ga 55% Al-Zn alloy coated steel with acrylic coating

Finish:

Color:

Trim Length:

Number of Pieces:

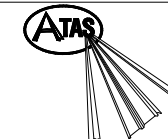

ATAS INTERNATIONAL, INC
 Allentown PA
 610-395-8445
 Mesa AZ
 480-558-7210

Note: * denotes color side.

Note: Trims shown as Standard, Job Specific Dimensions may alter Final Product Design.

REV. NO.				DATE				DESCRIPTION OF REVISION				BY				APP			
01				6/28/2022				Added Final Product Design Disclaimer				KRK							
DWG. NO.				DR				KRK				DATE				10/19/2020			
MATERIAL				SH. SIZE				A				SCALE				X:X			

TITLE Radius Trim Order Sheet - Ledge Flashing