

*OPTION AVAILABLE TO OMIT OFFSET CLEAT BY CHOOSING TO POP RIVET FRONT FACE OF SILL TRIM DIRECTLY TO PANEL.

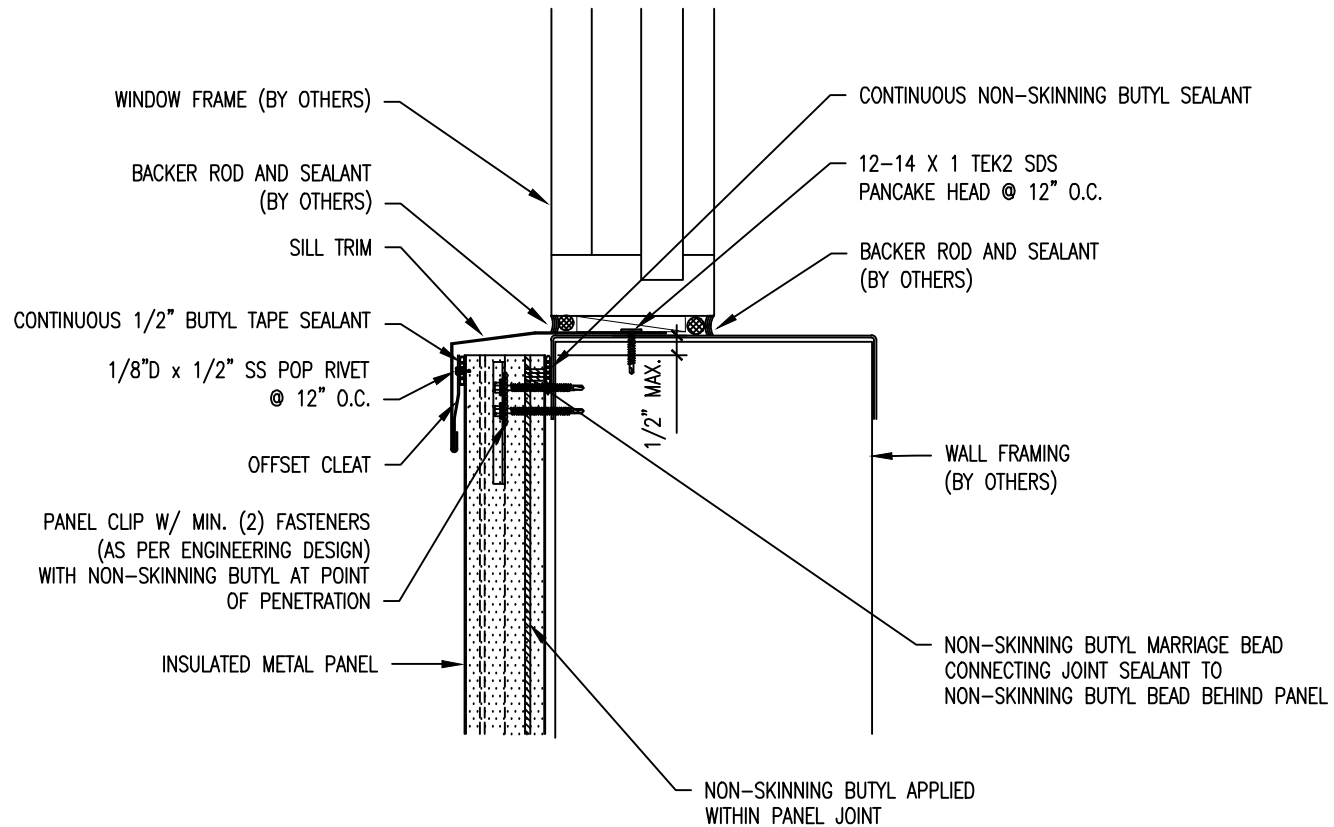

** THE DETAIL SHOWN IS SUBJECT TO CHANGE WITHOUT NOTICE.

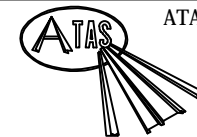

ATAS INTERNATIONAL, INC
 Allentown PA
 610-395-8445
 Mesa AZ
 480-558-7210

TITLE		Vertical Wall-Sheet Metal Flashing Window Sill	
DWG. NO.	DR	DATE	
MATERIAL	APP	DATE	
REV. NO.	DATE	SH. SIZE	SCALE
			X:X

REV. NO.	DATE	DESCRIPTION OF REVISION	BY	APP