

\*OPTION AVAILABLE TO OMIT OFFSET CLEAT BY CHOOSING TO POP RIVET FRONT FACE OF JAMB TRIM DIRECTLY TO PANEL.

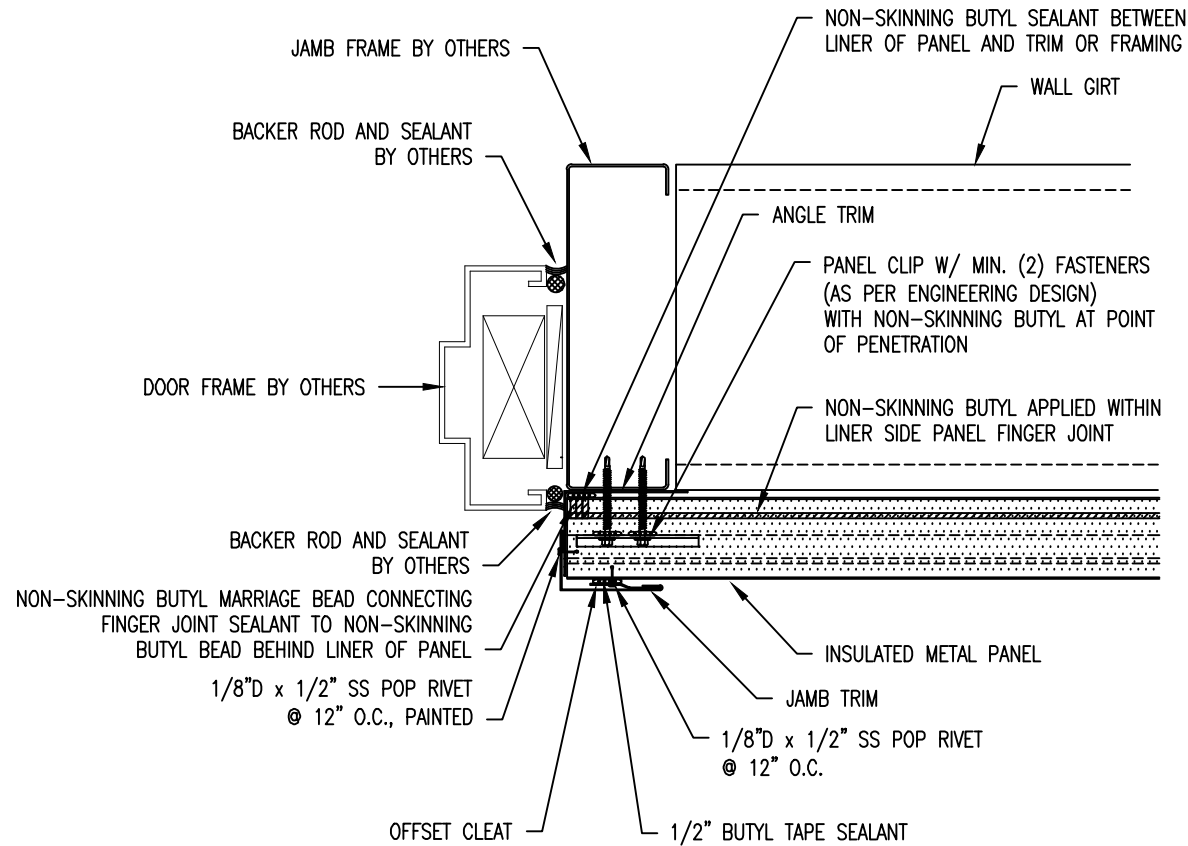

\*\* THE DETAIL SHOWN IS SUBJECT TO CHANGE WITHOUT NOTICE.

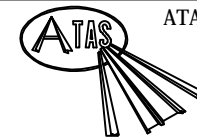

ATAS INTERNATIONAL, INC  
 Allentown PA  
 610-395-8445  
 Mesa AZ  
 480-558-7210

TITLE					Horizontal Wall-Sheet Metal Flashing-Door Jamb	
DWG. NO.			DR	DATE		
MATERIAL			APP	DATE		
REV. NO.	DATE	DESCRIPTION OF REVISION	BY	APP	SH. SIZE	SCALE
						X:X