

Out Elbow

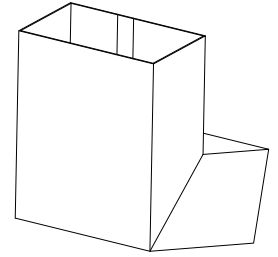

In Elbow

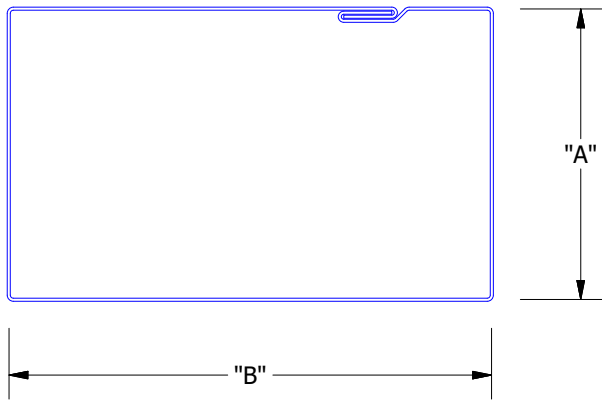

Downspout Interlock

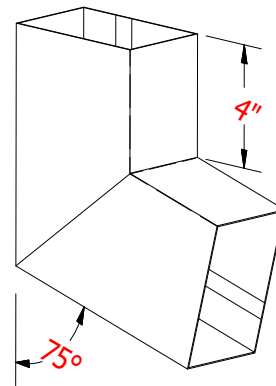

Right Elbow

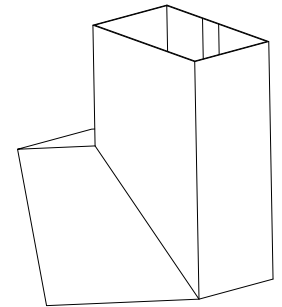

Left Elbow

Note: Downspout and Downspout Accessories are tapered unless otherwise specified.

Quantity:

____ Total LF (12'-0" pcs) ("A": _____) ("B": _____)
 (3) 1" wide straps furnished per 12'-0" section

Standard Accessories: Fabricated

- ____ Outlet Tube(s)
- ____ Box Downspout Out Elbow(s)
- ____ Box Downspout In Elbow(s)
- ____ Box Downspout Right Elbow(s)
- ____ Box Downspout Left Elbow(s)

MATERIAL:

THICKNESS:

- | | | | | |
|---|--------------------------------|--------------------------------|-------------------------------|-------------------------------|
| <input type="checkbox"/> Pre-Finished Aluminum | <input type="checkbox"/> .032 | <input type="checkbox"/> .040 | <input type="checkbox"/> .050 | <input type="checkbox"/> .063 |
| <input type="checkbox"/> Mill Finished Aluminum | <input type="checkbox"/> .032 | <input type="checkbox"/> .040 | <input type="checkbox"/> .050 | <input type="checkbox"/> .063 |
| <input type="checkbox"/> Pre-Finished Steel | <input type="checkbox"/> 24 ga | <input type="checkbox"/> 22 ga | | |
| <input type="checkbox"/> Stainless Steel | <input type="checkbox"/> 26 ga | | | |

COLOR: _____

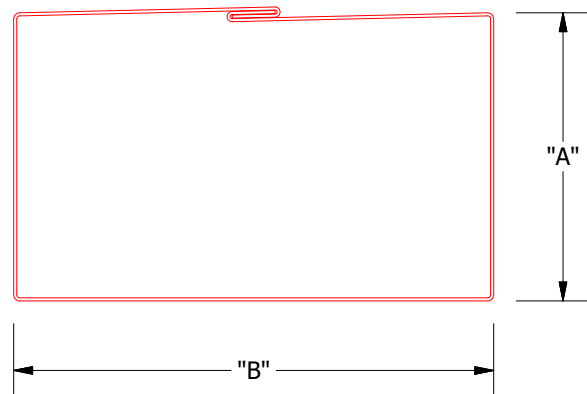

Downspout Accessories Interlock

Job Name: _____	Customer: _____
Job #: _____	Representative: _____
Location: _____	Distributor: _____

CUSTOMER APPROVAL

Authorized Signature: _____

Approved by: _____

Date: _____