

# Vertical Panel

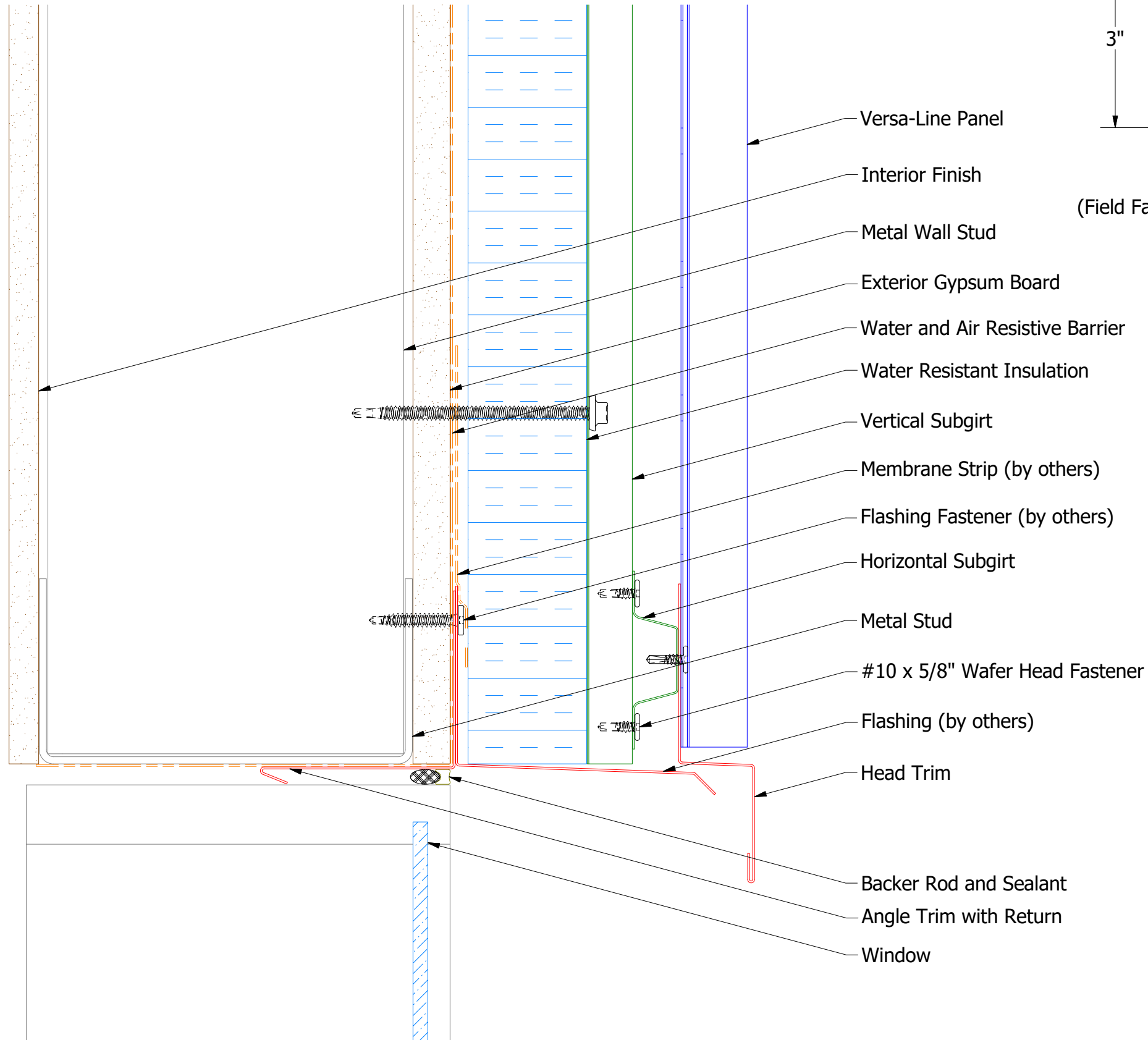

- Versa-Line Panel
- Interior Finish
- Metal Wall Stud
- Exterior Gypsum Board
- Water and Air Resistive Barrier
- Water Resistant Insulation
- Vertical Subgirt
- Membrane Strip (by others)
- Flashing Fastener (by others)
- Horizontal Subgirt
- Metal Stud
- #10 x 5/8" Wafer Head Fastener
- Flashing (by others)
- Head Trim
- Backer Rod and Sealant
- Angle Trim with Return
- Window

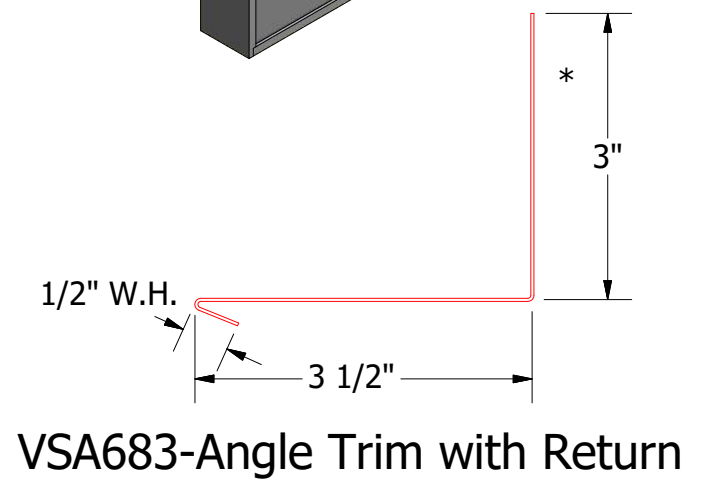
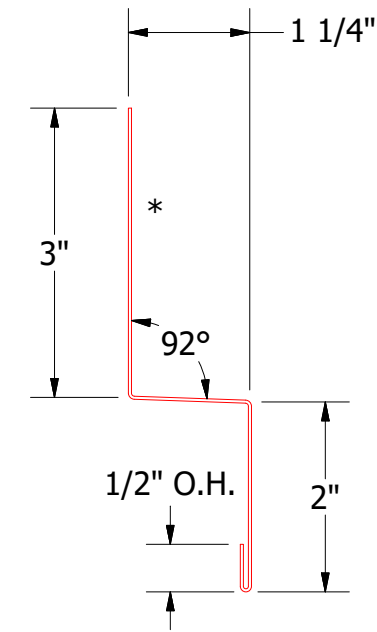
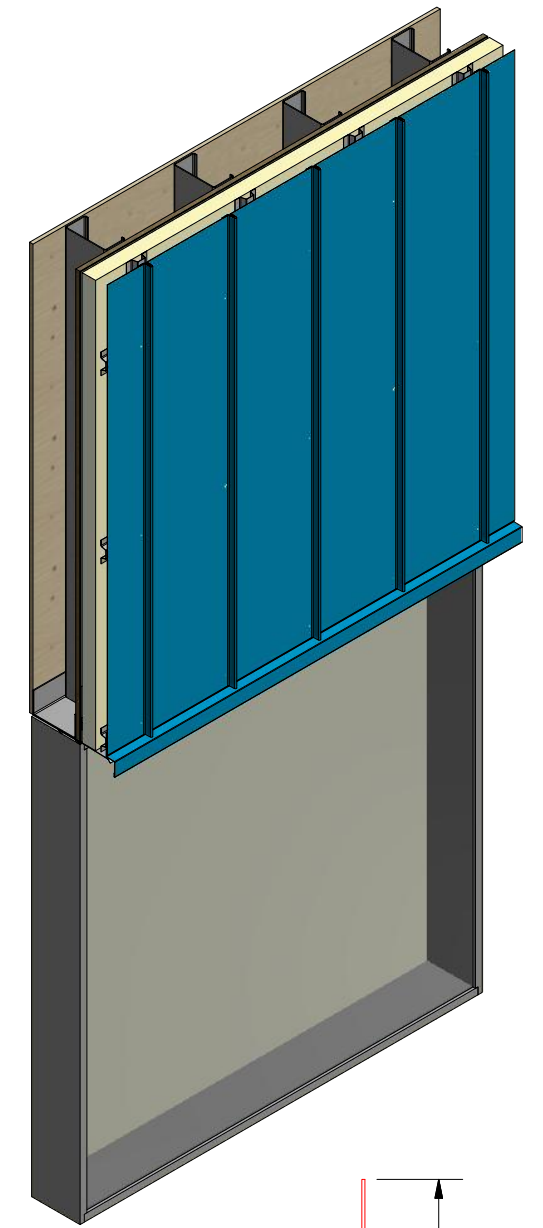
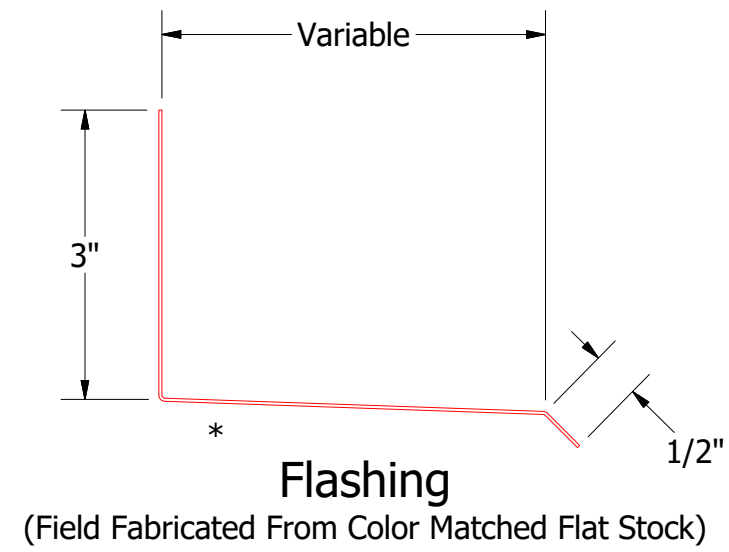

VSA550-Head Trim

VSA683-Angle Trim with Return

**ATAS** ATAS INTERNATIONAL, INC  
Allentown PA  
610-395-8445  
Mesa AZ  
480-558-7210

TITLE: **Versa-Line Open Head Detail**

DWG. NO.	DR	DATE
APP	DMR	1/23/2017
MATERIAL	APP	DATE
SH. SIZE	B	SCALE X:X

REV. NO.	DATE	DESCRIPTION OF REVISION	BY	APP