

Horizontal Panel

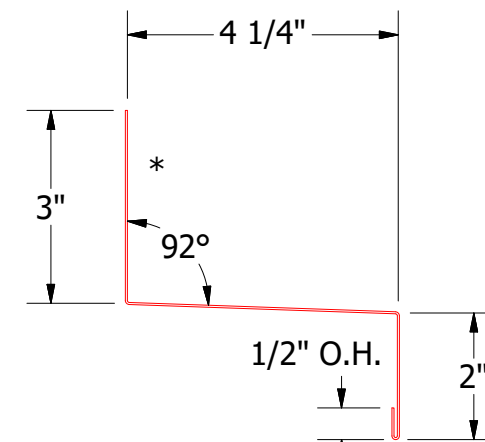

BSA550-Head Trim

2 Stage Method of Weather Proofing

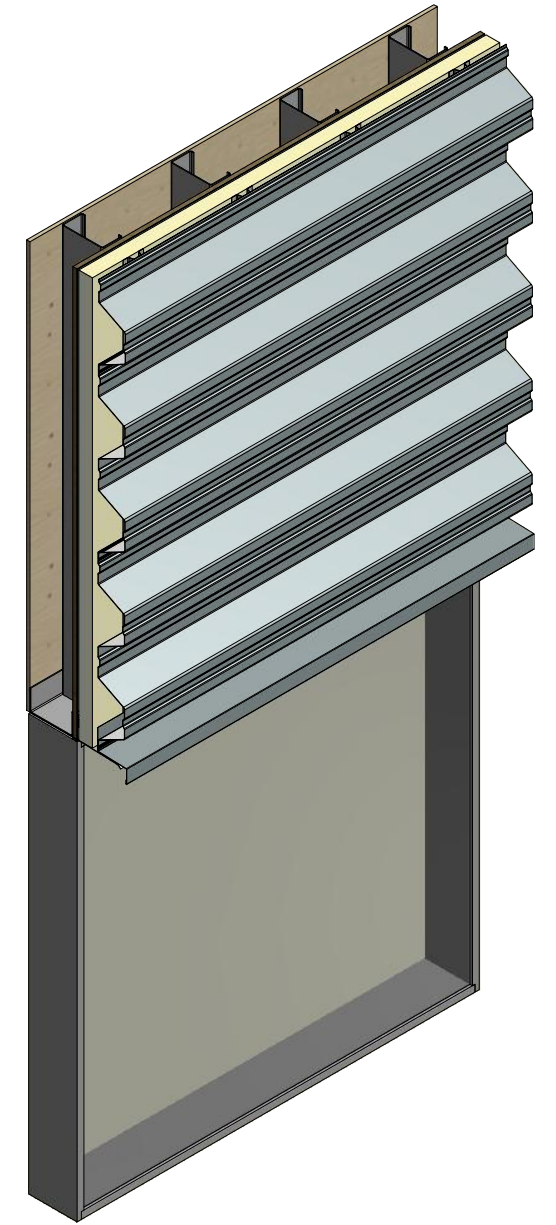
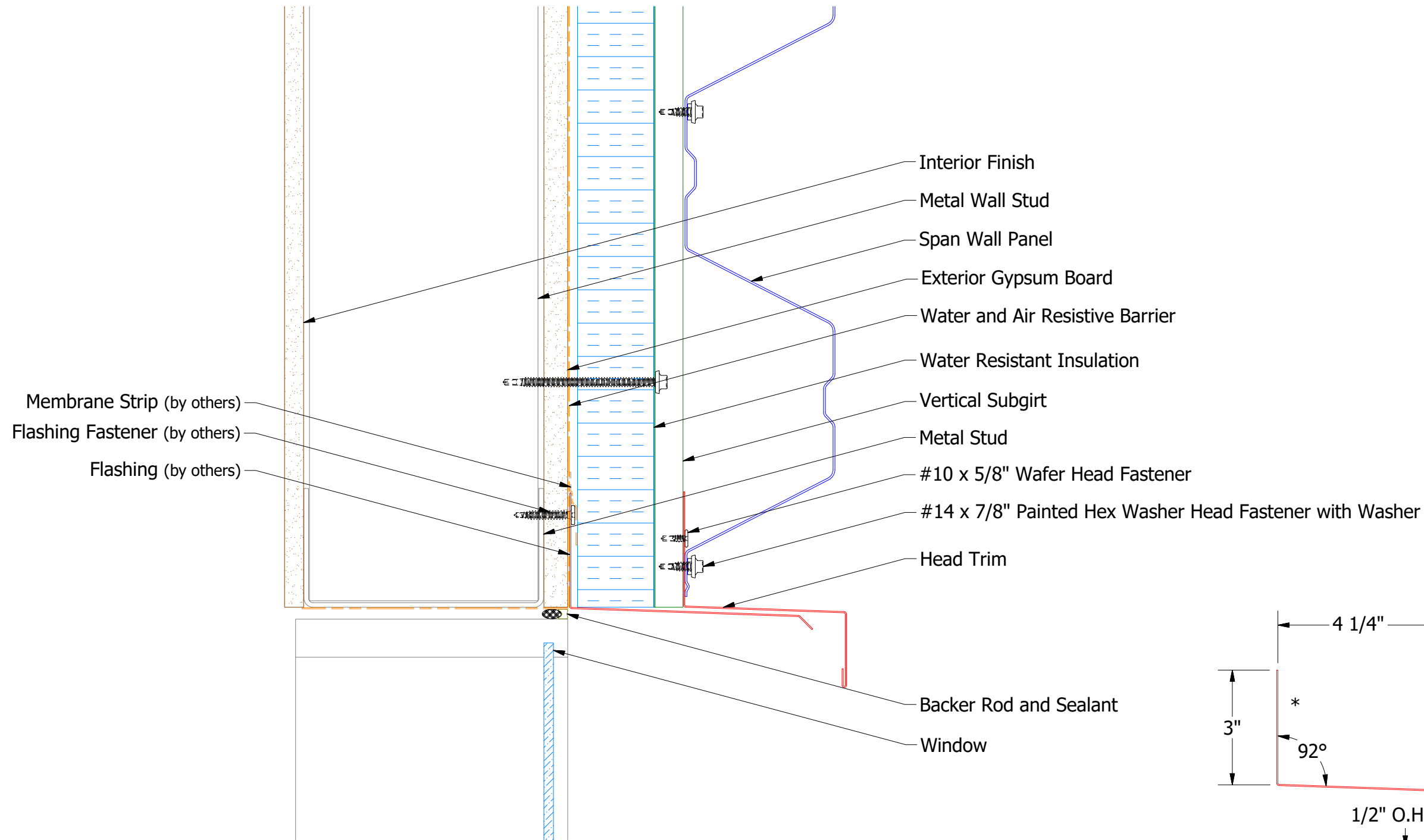

ATAS INTERNATIONAL, INC
 Allentown PA
 610-395-8445
 Mesa AZ
 480-558-7210

TITLE			
Span Wall Panel Head Detail			
DWG. NO.	DR	DATE	
	KRK	3/6/2015	
MATERIAL	APP	DATE	
REV. NO.	DATE	DESCRIPTION OF REVISION	BY APP
	SH. SIZE	B	SCALE X:X