

BOM per 12'		
Component	QTY (4"-12")	QTY (12"-32")
Coping Cover	1	1
20 GA 12" Intermediate Cleat Assembly	2	3
20 GA 12" Splice Cleat Assembly	1	1
10-13 x 1" GP Fastener	12	16
1 1/2" Ring Shank Nail	6	8

Dimensions		
Coverage (C)	Height (H)	Width (W)
2-1/2"	4-1/2"	4"-32"
4"	6"	4"-32"
5-1/2"	7-1/2"	4"-32"

Standard Materials	
Materials	Available Gauges
Pre-Finished Steel	24 GA, 22 GA
Stainless Steel	24 GA, 22 GA
Pre-Finished Alum.	.040, .050, .063
Mill Alum.	.040, .050, .063

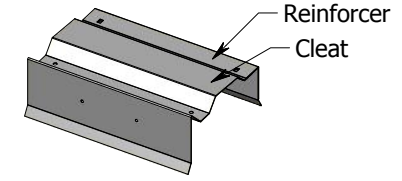
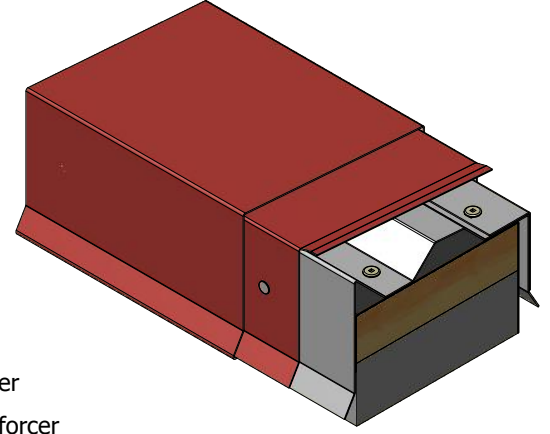
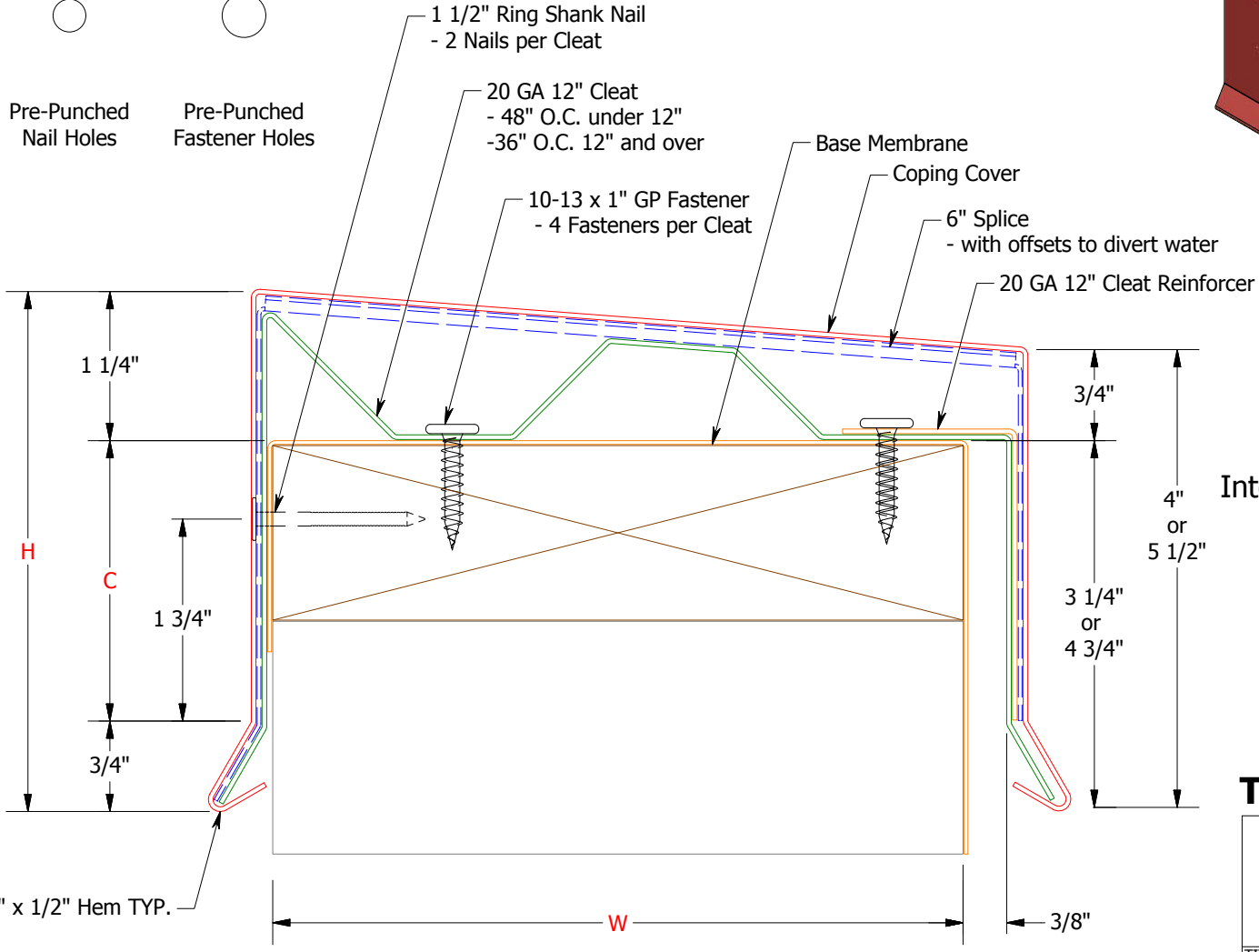
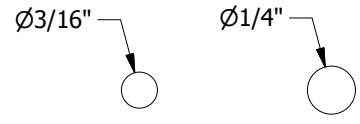

Intermediate Cleat Assembly

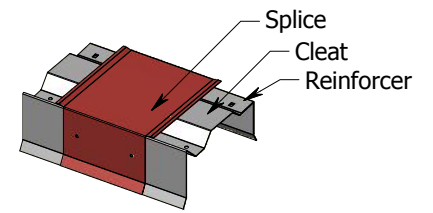

Splice Cleat Assembly

Tested per ANSI/SPRI ES-1

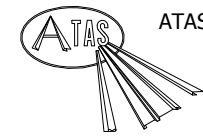

ATAS INTERNATIONAL, INC
 Allentown PA
 610-395-8445
 Mesa AZ
 480-558-7210

TITLE
Rapid Lok Coping Product Detail

02	12/7/2018	Updated Build of Materials Chart Cleat Designations	KRK	DWG. NO.	DR	PJR	DATE	08-21-15
01	7/6/2017	Updated Cleat Design	DMR	MATERIAL	APP		DATE	
REV. NO.	DATE	DESCRIPTION OF REVISION	BY	APP	SH. SIZE	A	SCALE	X:X