

Vertical Panel

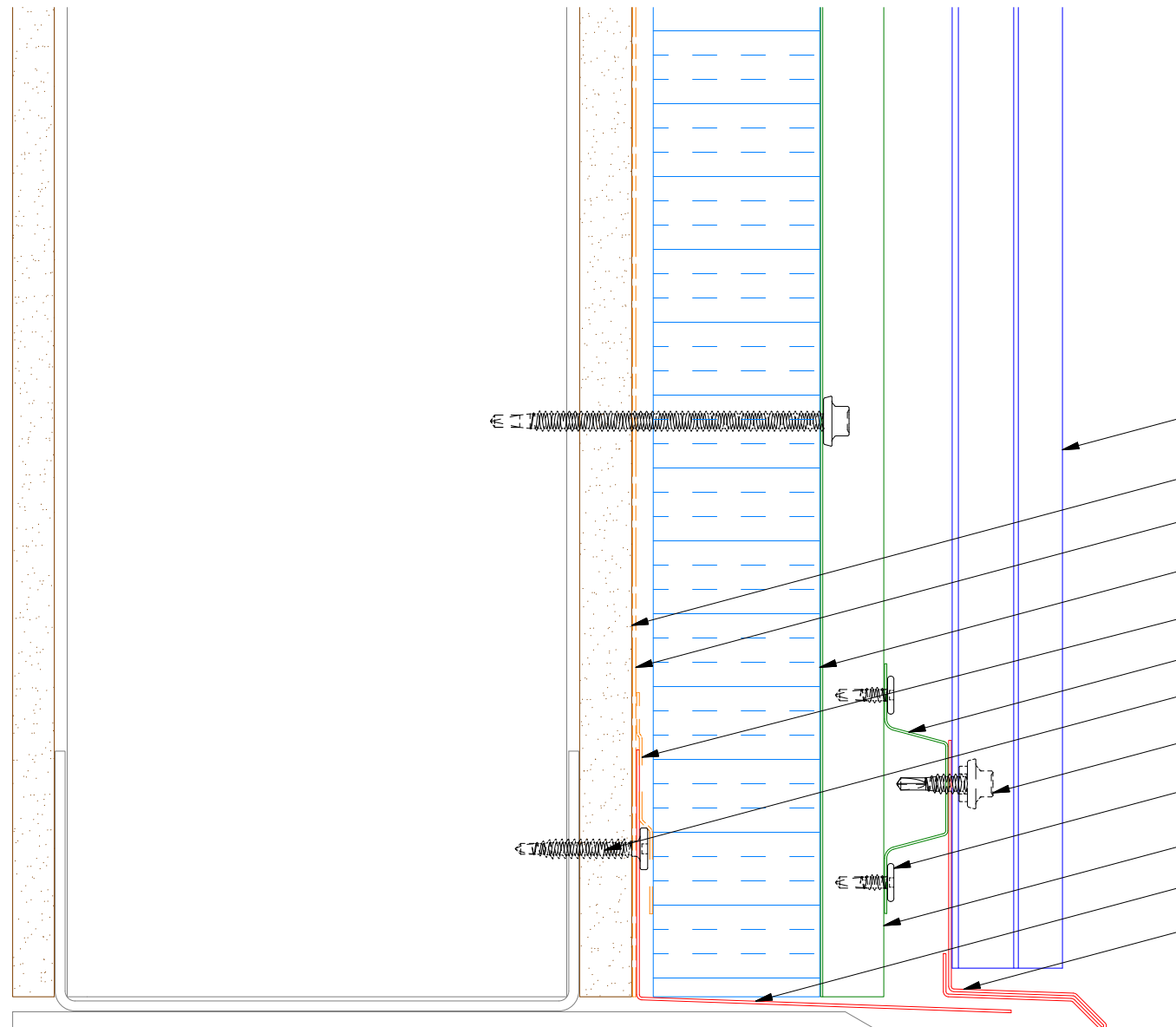

- PenumWall Panel
- Exterior Gypsum Board
- Water and Air Resistive Barrier
- Water Resistant Insulation
- Membrane Strip (by others)
- Horizontal Subgirt
- Flashing Fastener (by others)
- #14 x 7/8" Painted Hex Washer Head Fastener with Washer
- #10 x 5/8" Wafer Head Fastener
- Vertical Subgirt
- Flashing (by others)
- Base Trim

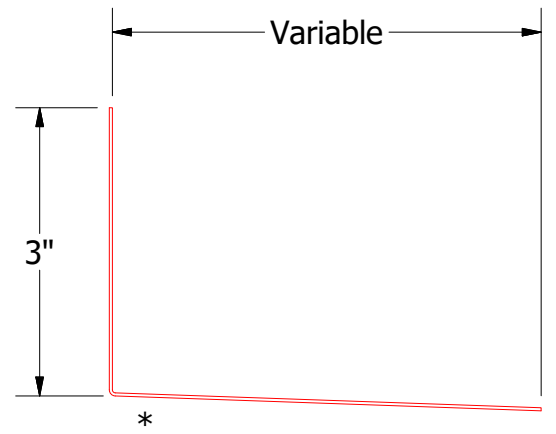
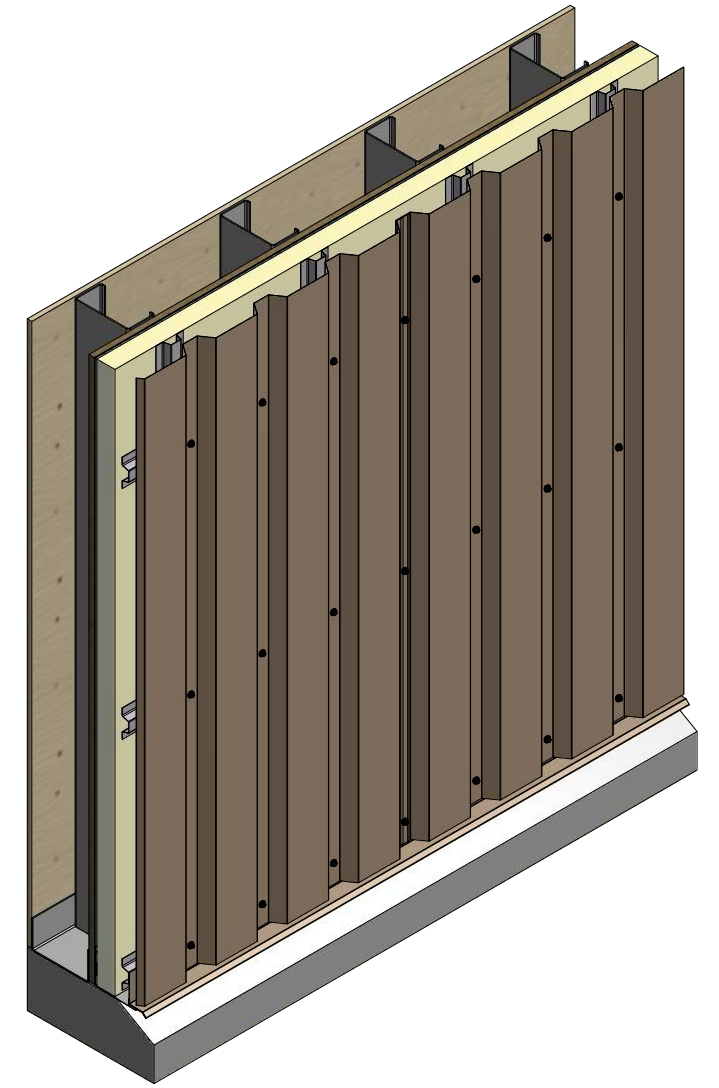

Flashing
(Field Fabricated From Color Matched Flat Stock)

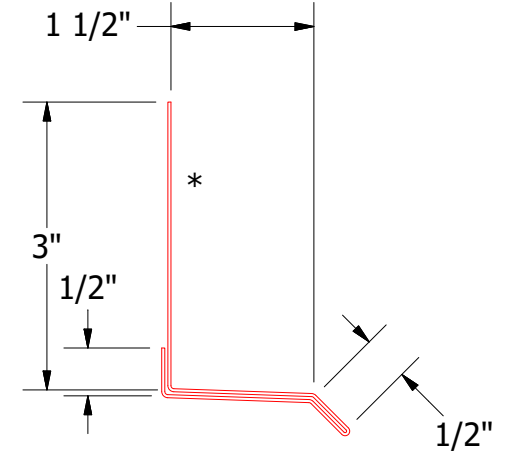

BPA661-Base Trim

Note: * denotes color side.

ATAS ATAS INTERNATIONAL, INC
 Allentown PA
 610-395-8445
 Mesa AZ
 480-558-7210

TITLE				DR		DATE	
PenumWall Open Base Detail				DMR	4/18/2017		
DWG. NO.				APP	DATE		
MATERIAL				SH. SIZE	B	SCALE	X:X
REV. NO.	DATE	DESCRIPTION OF REVISION	BY	APP			
01	4/12/2021	Added color side note.	KRK				