

Horizontal Panel

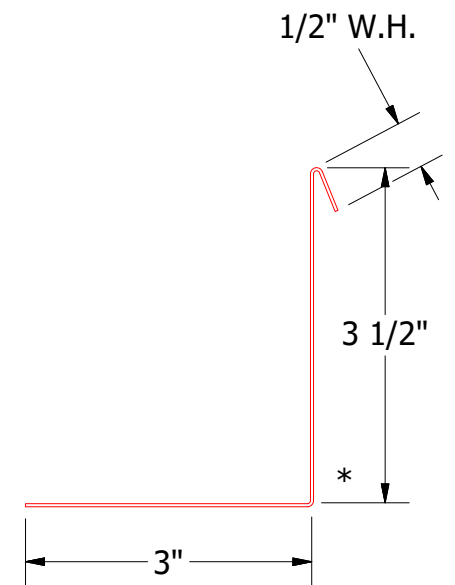

OPA683 - Angle Trim With Return

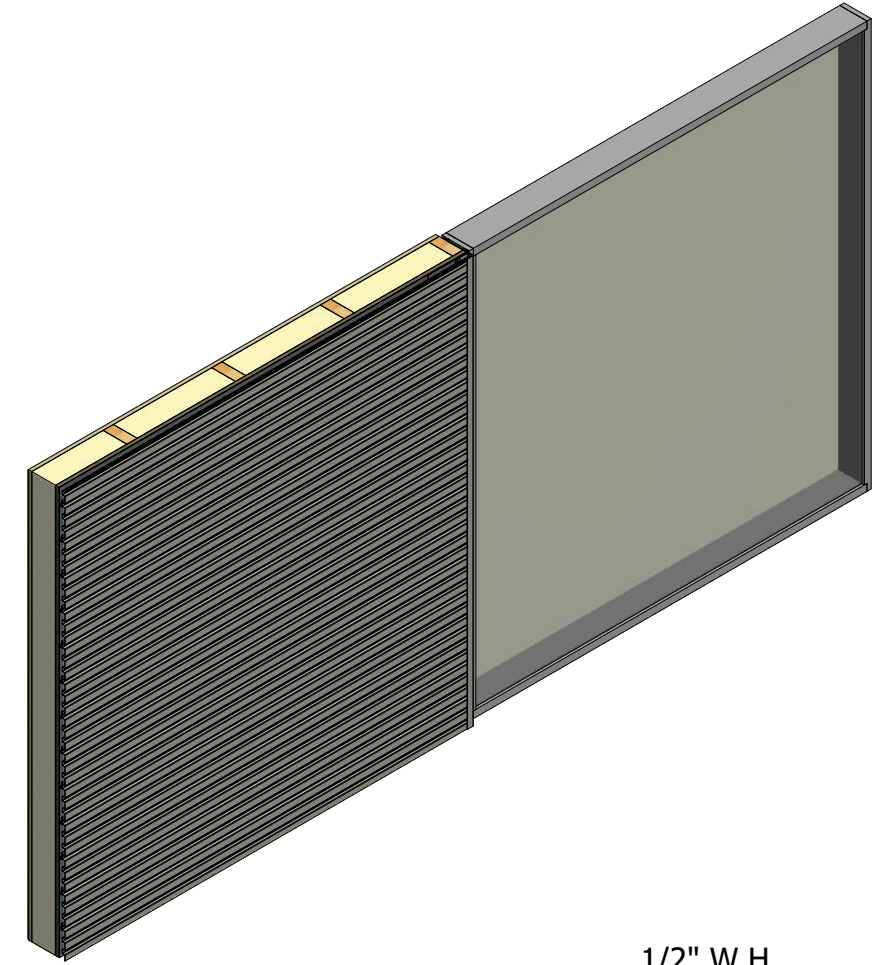
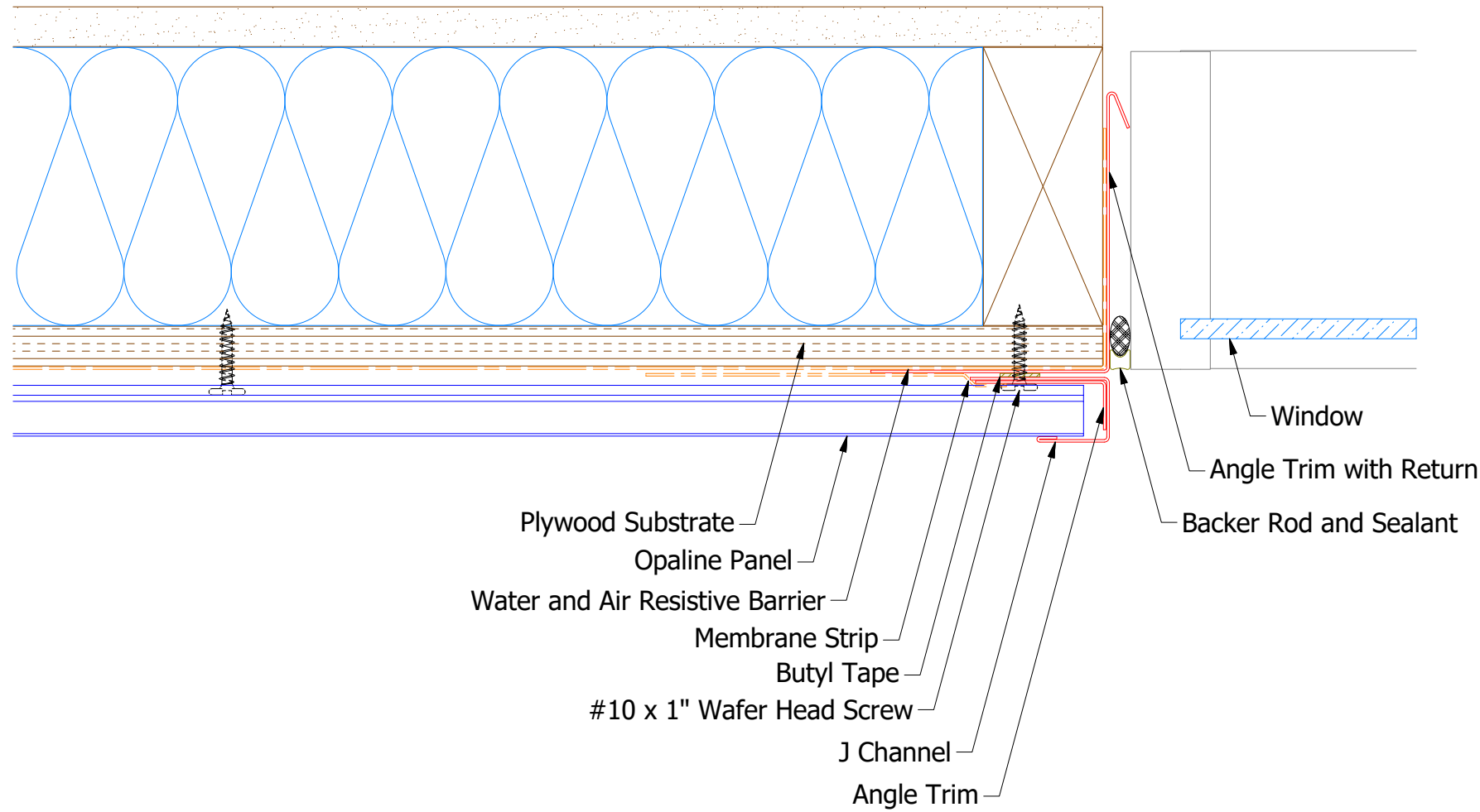
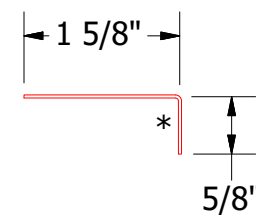

OPA680 - Angle Trim

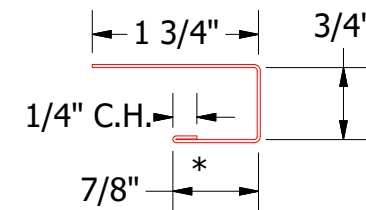

OPA034 - J Channel

Note: * denotes color side.

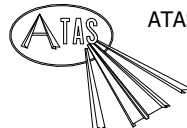
 ATAS INTERNATIONAL, INC Allentown PA 610-395-8445 Mesa AZ 480-558-7210		TITLE	
		Opaline Jamb Detail	
DWG. NO.	DR MBP	DATE	7/6/2016
	APP DAS	DATE	7/28/16
MATERIAL	SH. SIZE	SCALE	X:X
	B		

REV. NO.	DATE	DESCRIPTION OF REVISION	BY	APP