

Vertical Panel

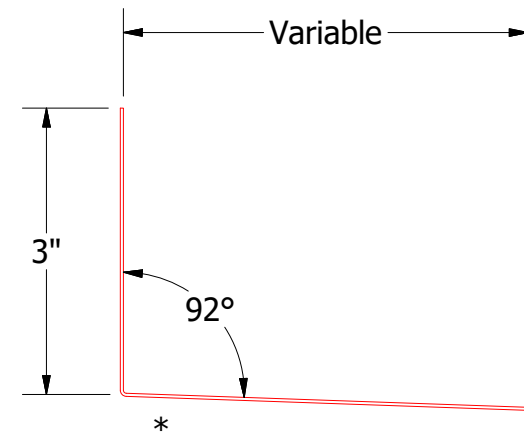

Flashing
(Field Fabricated From Color Matched Flat Stock)

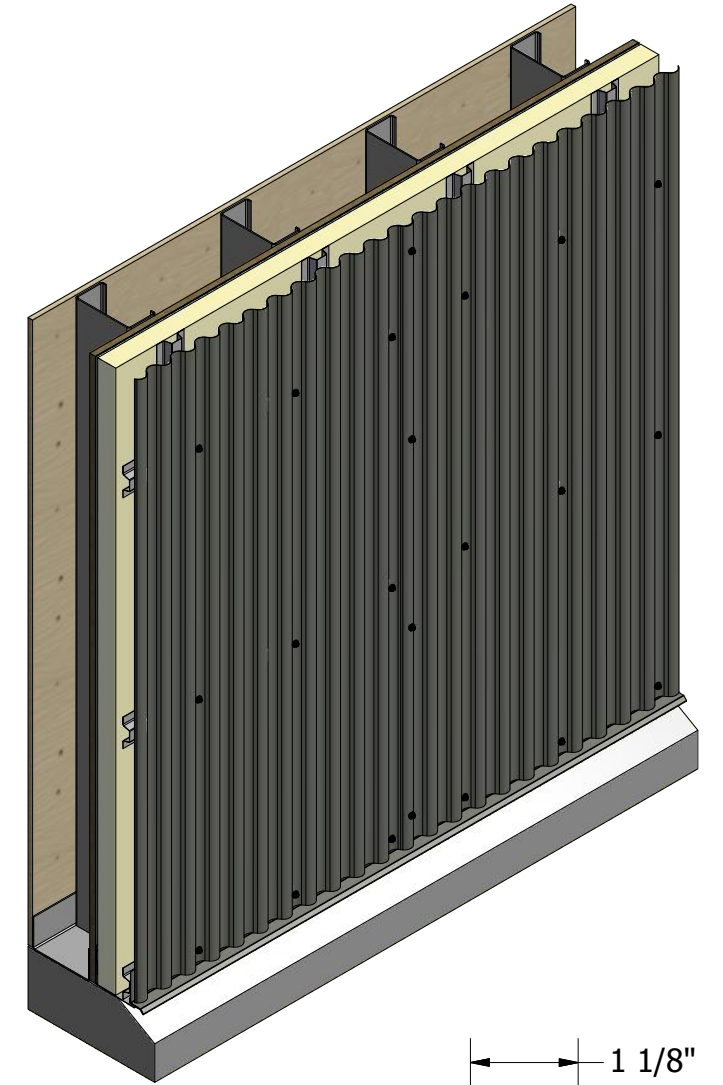
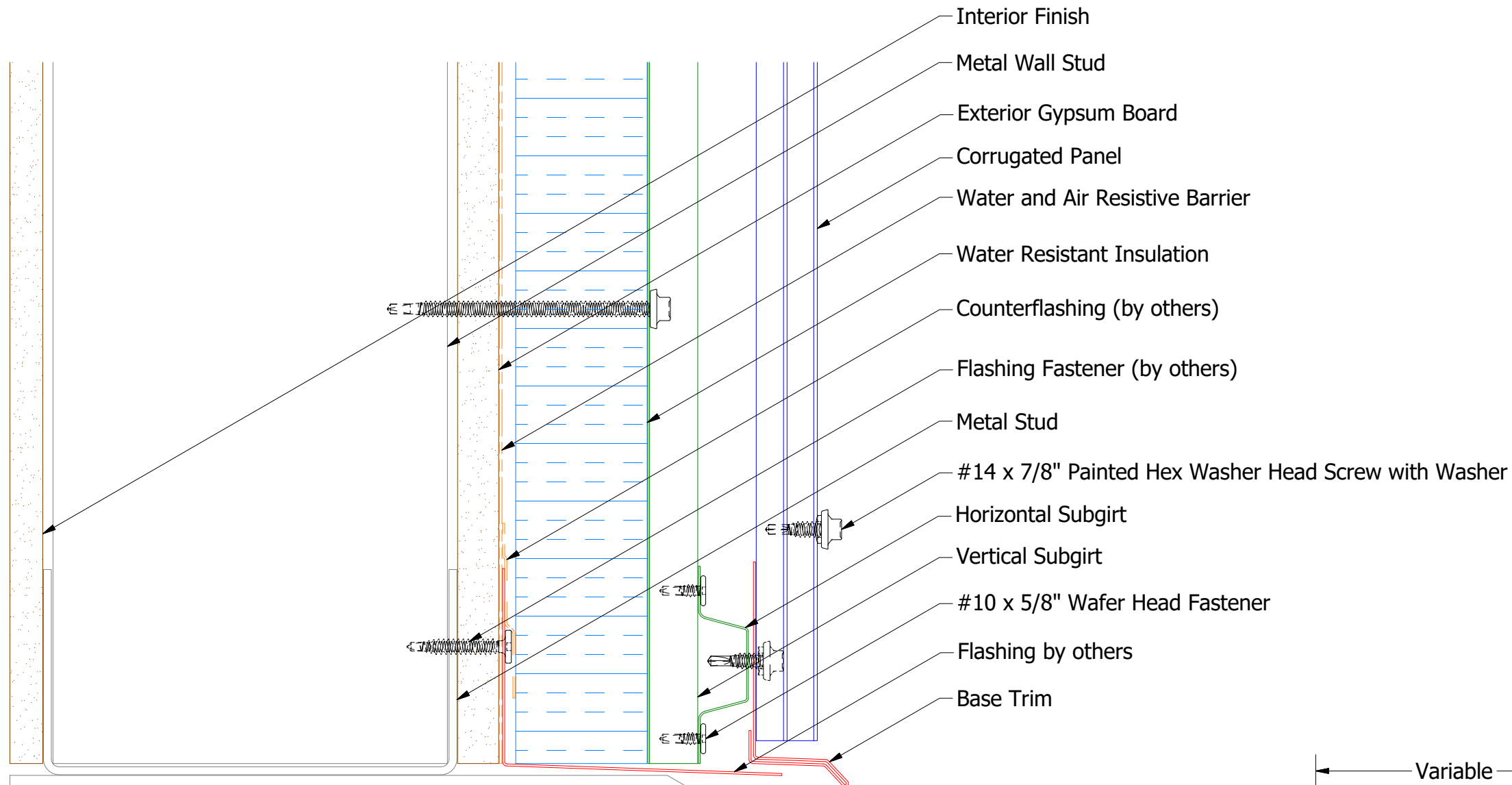
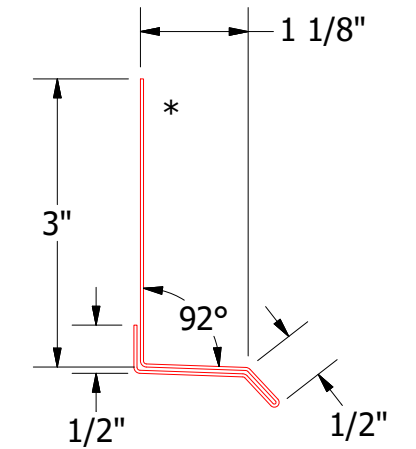

BCA661-Base Trim

2 Stage Method of Weather Proofing



ATAS INTERNATIONAL, INC
 Allentown PA
 610-395-8445
 Mesa AZ
 480-558-7210

TITLE		Corrugated Panel Base Detail	
DWG. NO.	DR	KRK	DATE
	APP		DATE
MATERIAL	SH. SIZE	B	SCALE
			X:X

REV. NO.	DATE	DESCRIPTION OF REVISION	BY	APP