

BOM per 12'	
Component	Quantity
Coping Cover	1
Splice	1
Continuous 22 GA Cleat	1
9-15 x 1 1/2" HHSS Fast.	9
1 1/2" Ring Shank Nail	17

Standard Materials	
Material	Available Gauges
Pre-Finished Steel	24 GA, 22 GA
Stainless Steel	24 GA, 22 GA
Pre-Finished Alum.	.040, .050, .063
Mill Alum.	.040, .050, .063

Dimensions		
Coverage (C)	Height (H)	Width (W)
2 1/2"	4"	4" - 10"
4"	5 1/2"	4" - 10"

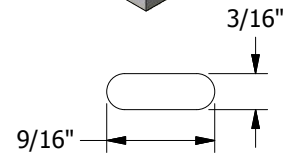
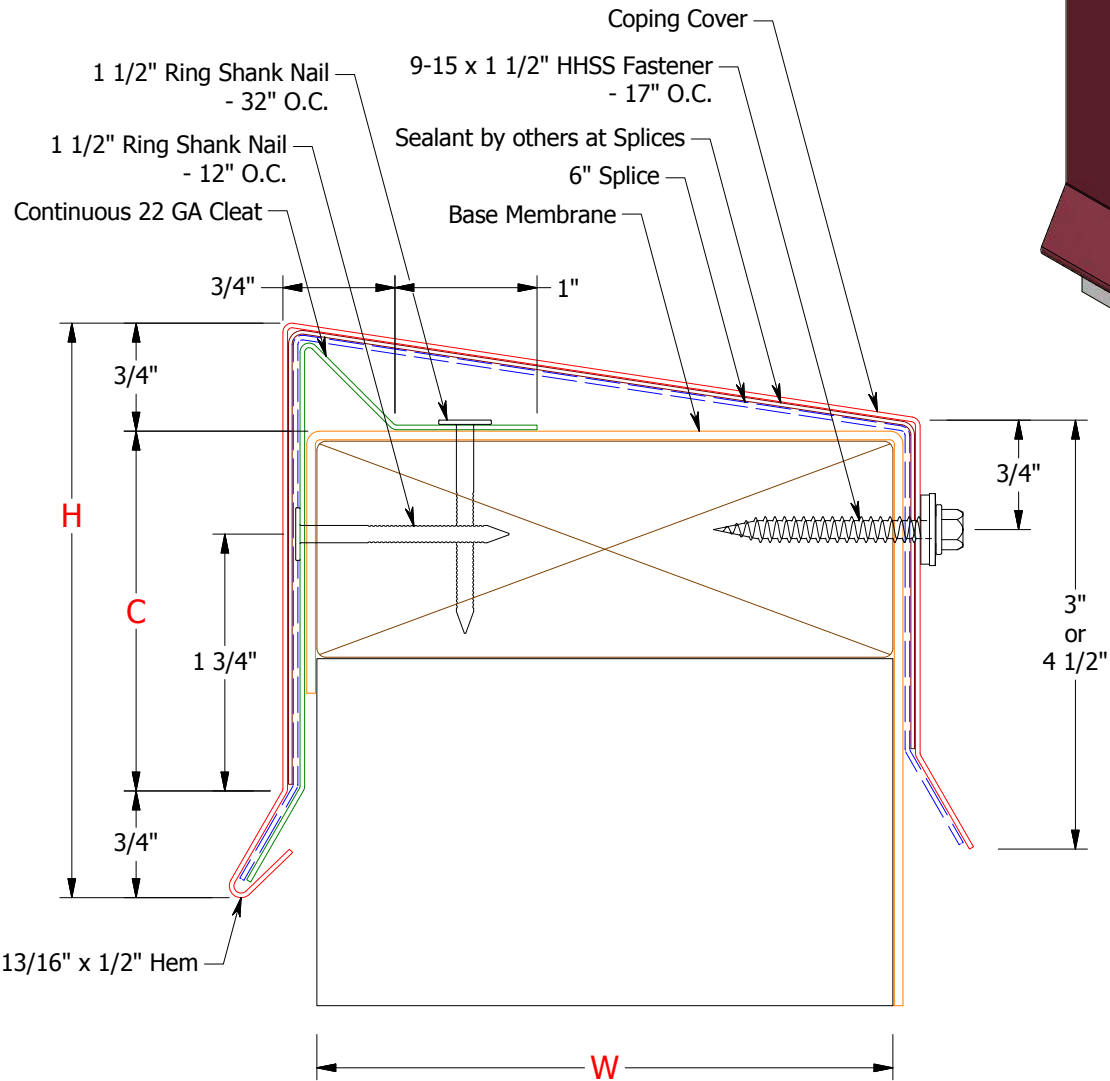
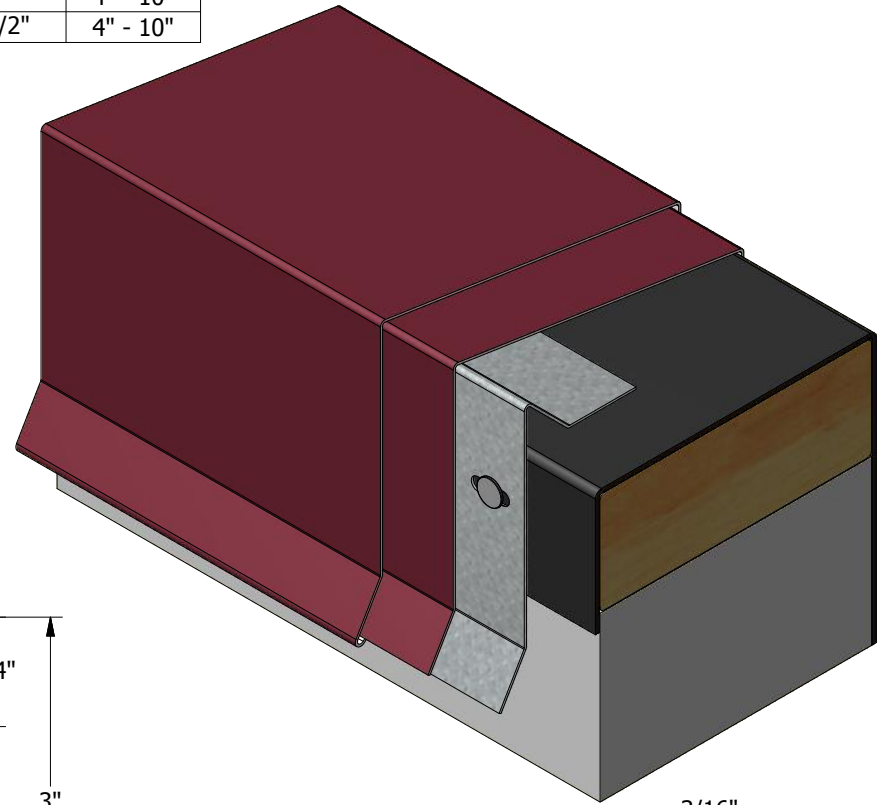

Slotted Fastener and Nail Holes

**Tested per ANSI/SPRI ES-1**

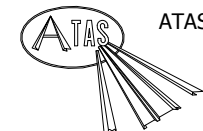

ATAS INTERNATIONAL, INC  
 Allentown PA  
 610-395-8445  
 Mesa AZ  
 480-558-7210

REV. NO.	DATE	DESCRIPTION OF REVISION	BY	APP

TITLE Continuous Cleat Coping Product Detail		
DWG. NO.	DR PJR	DATE 08-27-15
MATERIAL	APP	DATE
SH. SIZE A	SCALE X:X	

BOM per 12'	
Component	Quantity
Coping Cover	1
Splice	1
Continuous 22 GA Cleat	1
9-15 x 1 1/2" HHSS Fast.	9
1 1/2" Ring Shank Nail	17

Standard Materials	
Material	Available Gauges
Pre-Finished Steel	24 GA, 22 GA
Stainless Steel	24 GA, 22 GA
Pre-Finished Alum.	.040, .050, .063
Mill Alum.	.040, .050, .063

Dimensions		
Coverage (C)	Height (H)	Width (W)
2 1/2"	4"	10" - 24"
4"	5 1/2"	10" - 24"

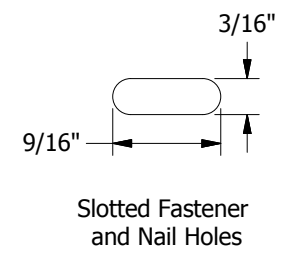
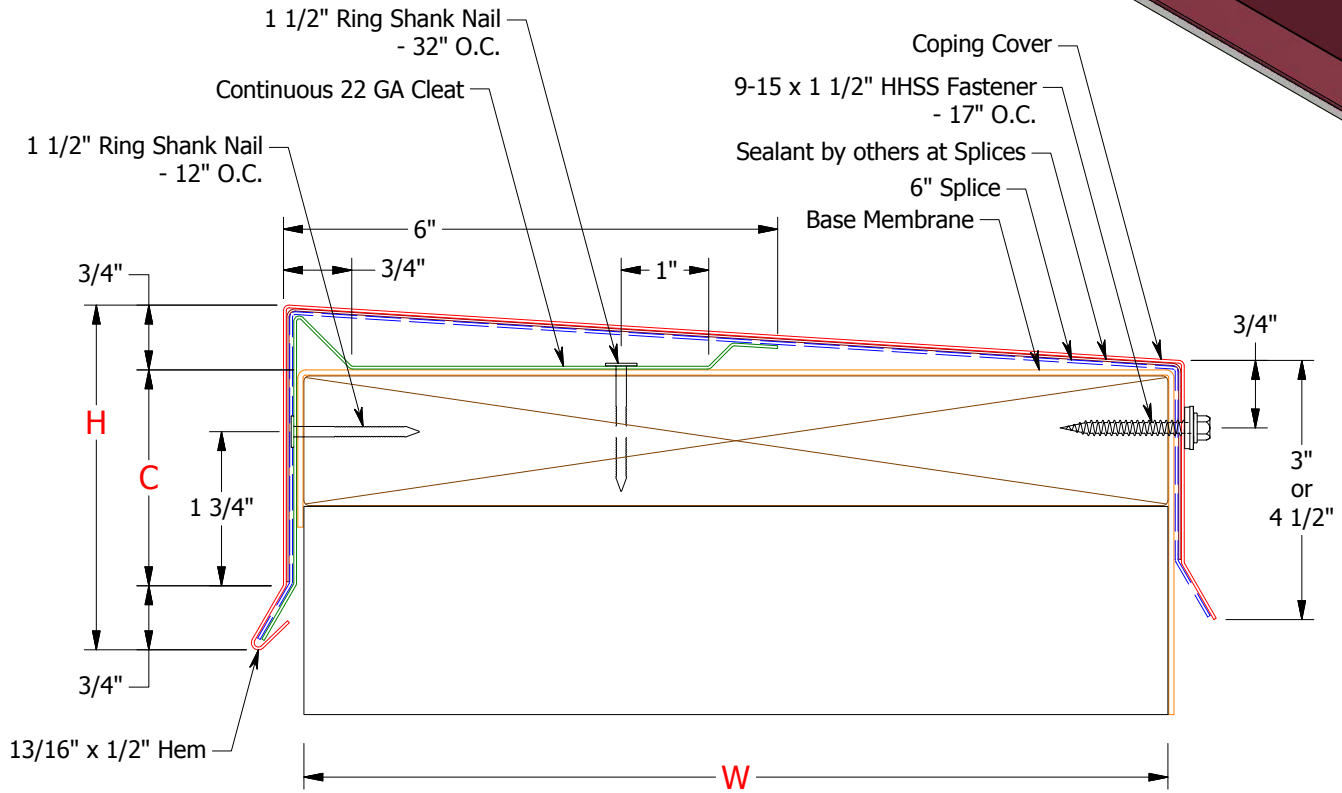
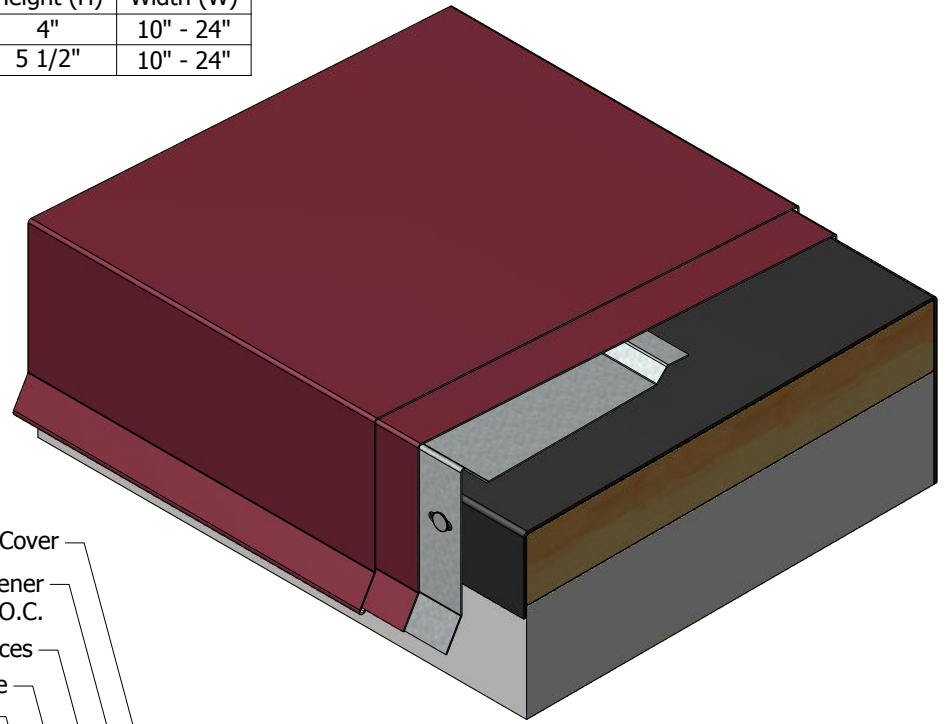

**Tested per ANSI/SPRI ES-1**

**ATAS** INTERNATIONAL, INC  
 Allentown PA  
 610-395-8445  
 Mesa AZ  
 480-558-7210

TITLE					Continuous Cleat Coping Product Detail		
DWG. NO.					DR	PJR	DATE
					APP		08-27-15
MATERIAL					SH. SIZE	A	SCALE
							X:X
REV. NO.	DATE	DESCRIPTION OF REVISION	BY	APP			