

# Installation Guide

Permashake panels are simulated wood shakes manufactured from 29 gauge G90 galvanized steel. They are available in 6 standard colors with a Hylar 500<sup>®</sup> and/or Kynar 5000<sup>®</sup> finish. They measure 10 5/8" (nom.) x 61" (nom.) Minimum recommended roof pitch is 4:12.

There are twelve (12) Permashake panels packaged per carton. Approximately twenty-four (24) panels equal a square. Panels are always installed left to right and should have a minimum of three (3) anchor clips.

**Review and understand complete guide before beginning installation.**

This guide has been prepared as suggested details to particular design conditions. Each condition has certain limitations to performance, aesthetics or economics. Professionals qualified to assess this information for a specific project, should determine that the selection and installation are made to their requirements. ATAS **cannot** assume any responsibility for the actual selection and/or installation of materials. The panels, flashings and trim shown in this guide, illustrated over solid and plumb substrate, assume that the structure has been designed and prepared in accordance with local building codes.

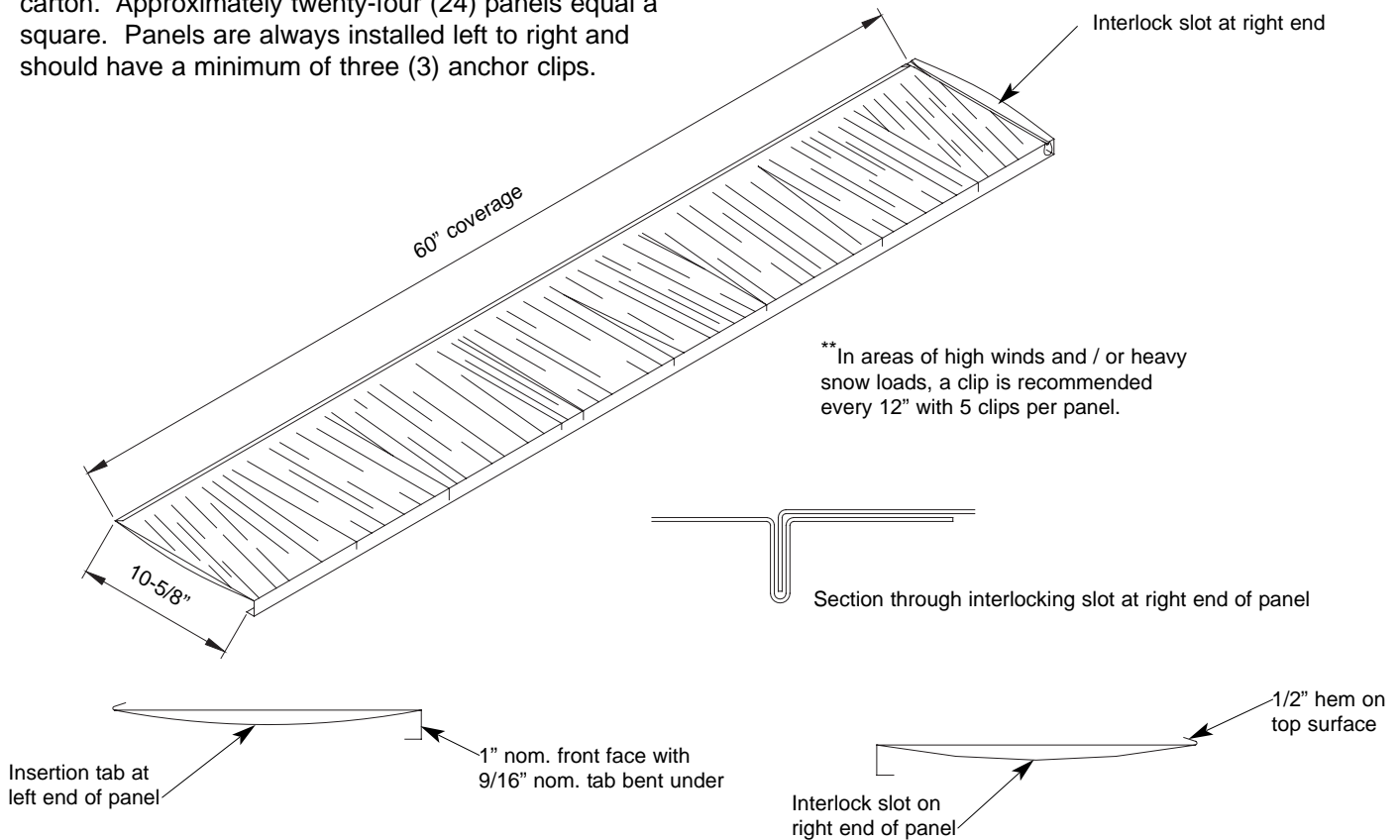

**PANEL INSTALLATION** - In environments where ice and water may dam, apply ATA Shield<sup>™</sup> underlayment over entire substrate. Begin installation over solid deck by applying ATA Shield<sup>™</sup> around perimeters of roof with a minimum of 36" coverage. Then apply ATA Guard<sup>™</sup> or appropriate underlayment over roof deck. Snap a vertical and horizontal line to square up the plane with the eave line. Start at the bottom left hand corner of the roof plane with a full length panel. Install shingles in a left to right manner from eave to ridge. See below for stagger methods of installation. Fasten panels to solid substrate with galvanized steel clips using a minimum of three (3) to a panel. Manufacturer recommends the use of 1" wafer head screws.

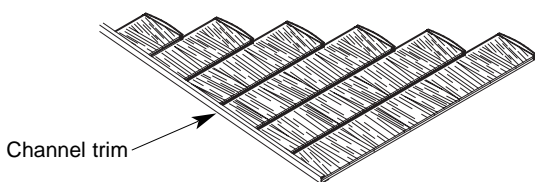

**STEP STAGGER METHOD**  
Each course 10" to the left of the lower course.

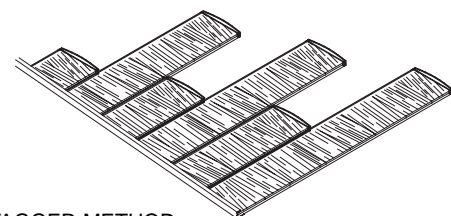

**RANDOM STAGGER METHOD**  
Cut and start each course as follows beginning at the lower left edge of the roof.

# Eave Detail

1. When applying a re-roof application, cut back existing shingles and drip edging to be flush with eave and gable lines.
2. Apply ATA-Shield\*\* in areas where ice & water damming can occur. Extend underlayment over fascia board. Install drip edge as tight as possible against the fascia trim. Space fasteners at maximum of 12" o.c. Overlap eave trim a minimum of 3".
3. Lay a full width of ATA-Guard\* over the eave trim. Apply butyl tape on top of drip edge and fasten starter cleat through eave trim into substrate with front face up as shown to right.
4. Install panel only after the gable closure is installed (see below). Install by sliding lower flanged edge between starter cleat and drip edge. Square the panel in the J channel at the gable edge and fasten with clips and a 1" wafer head screw.

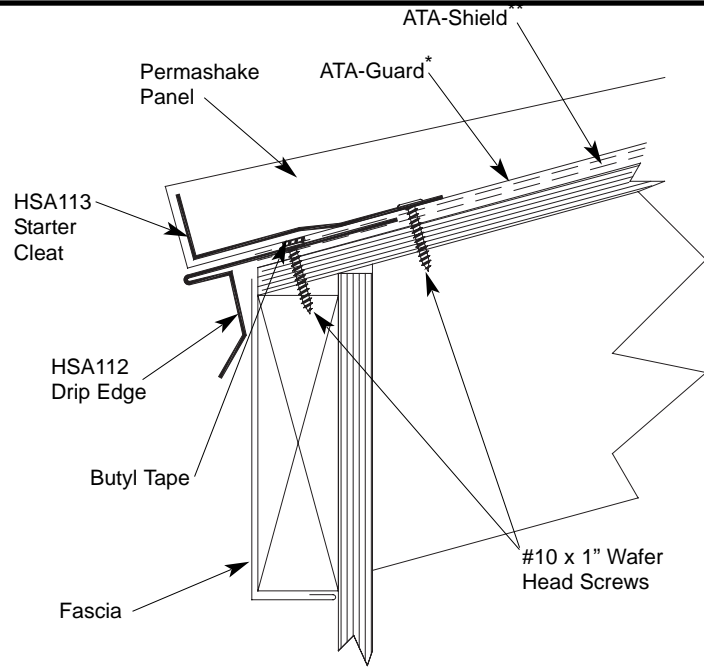

# Gable Detail

1. Install drip edge over ATA-Guard\*
2. Apply sealant along drip edge as shown to the right. Lay the channel trim along the gable edge. Overlap channel at a minimum of 2" to 4".
3. Align the first shingle into the J channel and snap a line across the roof plane. (See panel installation section)

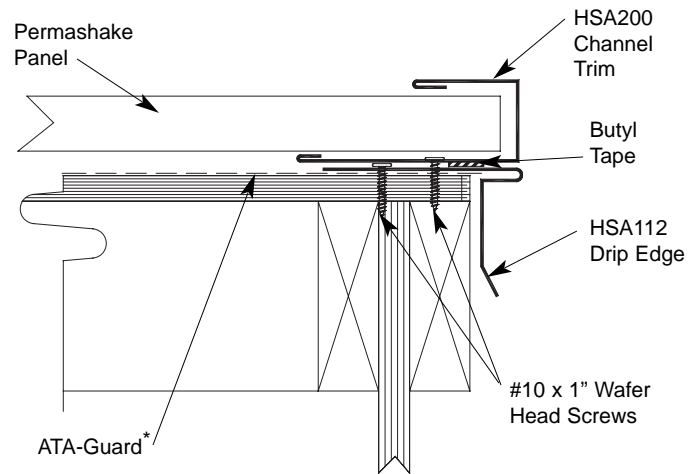

# Valley Detail

1. Install ATA-Shield\*\* 18" up both sides of the valley line.
2. Install the valley pan and clip fasten through the substrate at 24"-0" o.c.
3. Lay shingles onto the valley pan maintaining at least 3" clearance from the valley's center.

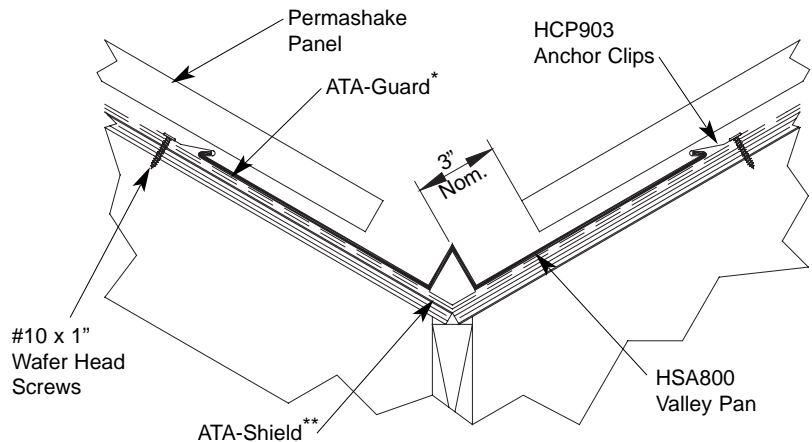

**Underlayments:** ATA-Guard\* is a polyolefin based, 100% asphalt free, high strength reinforced roofing underlayment for use beneath metal roofing on steep slope applications. 1000 sq. ft. per roll at 48" wide.

**Underlayments:** ATA-Shield\*\* is the recommended self adhesive underlayment for eaves, sidewall and any critical areas exposed to ice damming and extensive water run off. Available in 65'-8" x 39-3/8" rolls (2000 sq. ft. per roll).

# Hip & Ridge Detail

*Hip and ridge applications are handled in the same manner.*

1. Install roof panels to meet at hip or ridge. (Depending on roof geometry and run of roof, the top panel may have to be cut along the length of panel.
2. Lay a 6" strip of closure tape across hip/ridge line.
3. Lay cap on roof and chalk a line to mark placement of butyl sealant tape.
4. Secure the cap with a 2" x 5/16" painted/gasketed screw approx. 2'-0" o.c.

*Ridge caps can accommodate standard ridge venting products. Refer to venting manufacturer's instructions and local building code requirements.*

*Note: For hip applications, fasten the caps to the high point on the shingle in order to avoid dimpling, and make sure the screw penetrates the cap through the butyl sealant tape into the solid substrate.*

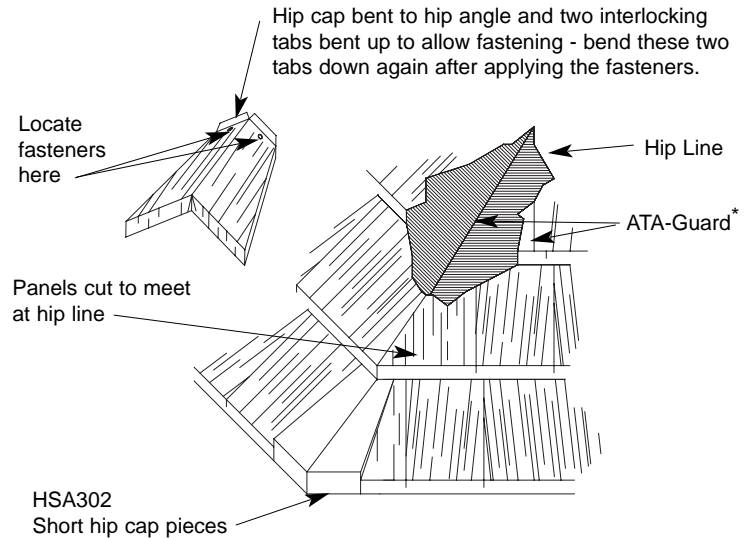
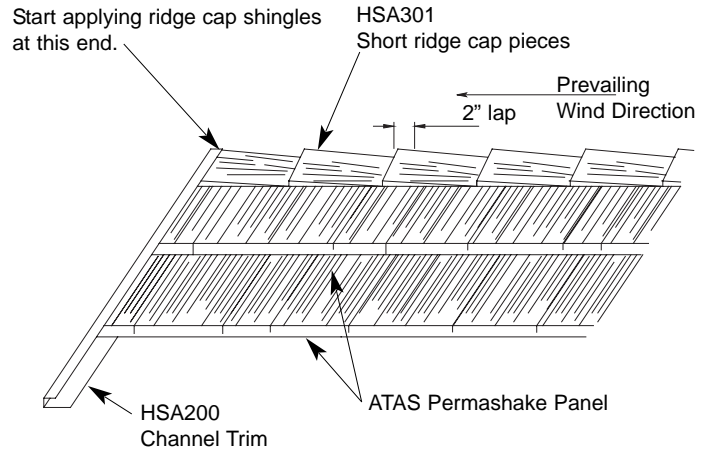

# Headwall Detail

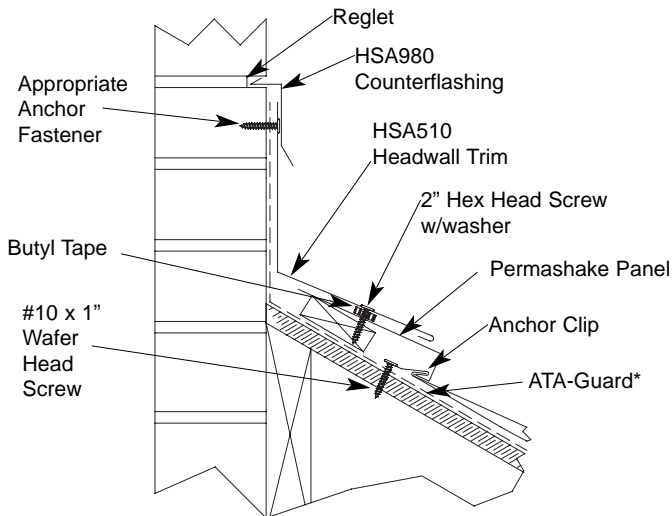

1. Install metal shingles up to the headwall. Shim the panel if necessary as shown above..
2. Lay headwall trim over the shingles while insuring that the perpendicular section is flush against the headwall. use double faced caulk tape between the panel and trim assemblies.
3. Apply counterflashing over the headwall trim as required, or install wall paneling.

# Shed Ridge Detail

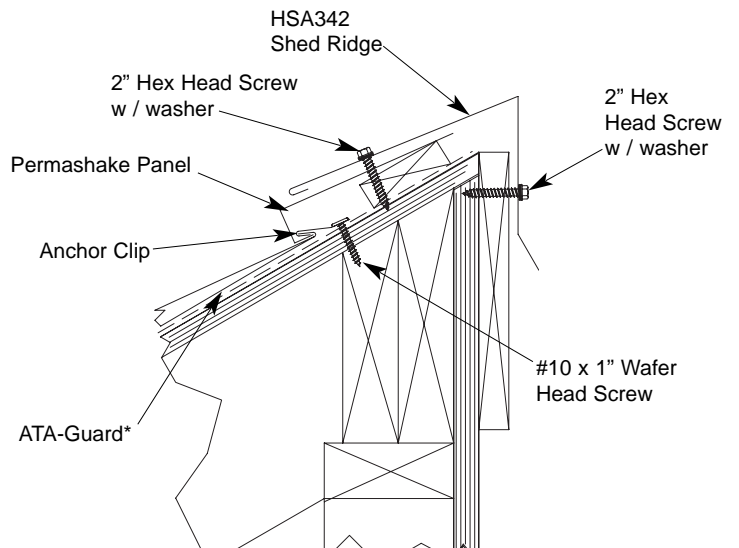

1. Install metal shingles up to the shed ridge peak. Shim panel if necessary as shown above.
2. Place double faced caulk tape just inside hem of Shed Ridge Trim. Fit trim to peak. Fasten through tape and shingle into solid substrate. Use 2" x 5/16" painted / gasketed screws.
3. Front face fasten Shed Ridge Peak Trim to facade.

# Sidewall Detail

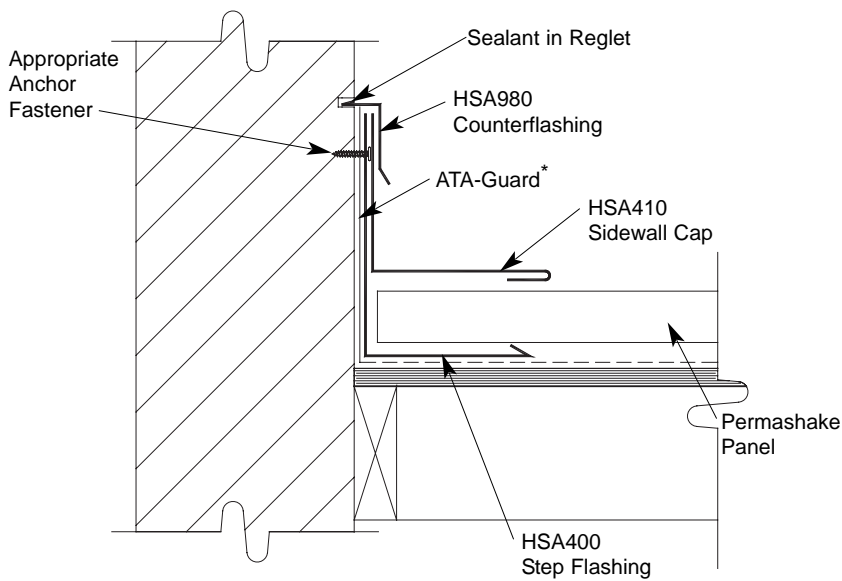

1. Install ATA-Shield\*\* along roof plane and up side-wall.
2. Install step flashing tight against the sidewall.
3. Install the panel up to the wall. Fasten the panel as close to the wall as possible without penetrating the step flashing.
4. Install the sidewall cap and fasten in place.
5. If the wall treatment is siding, it should lay over the sidewall trim. If brick or stucco, a reglet should be used with counterflashing to seal. Be sure to seal reglet.

*Note: Step flashing is designed to drain onto the top side of lower panel. The panel that overlaps step flashing should be notched to allow water to drain out.*

## Note Regarding Trim Details

The application of flashing and trim requires a detailed approach. Consideration should be given to the roof's geometry and course it creates for water run-off. Location of gutters and the use of snow retention systems should also be considered. Proper planning regarding the sequence of material overlap is critical. Sealants, such as butyl tapes and tripolymers, should be used at overlapping trim edges, in conjunction with exposed fasteners, and to seal flashings. All fasteners should be properly tightened and not over driven at an angle. Fasteners that are too loose can "back out" over time. An overdriven fastener may cause a depression in the material, which becomes a collection point for standing water.

# Pipe Detail

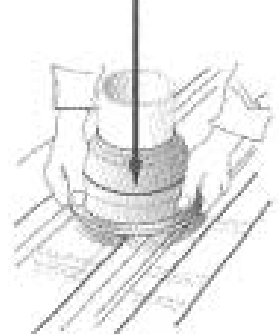
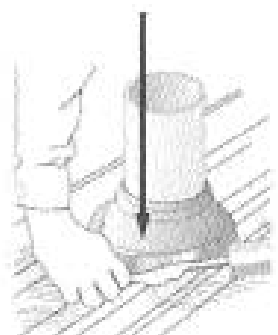
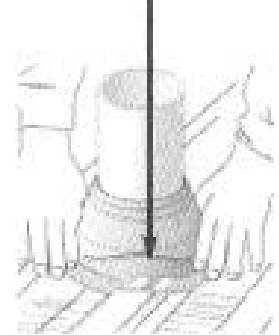
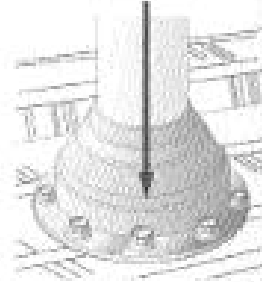
<p><b>Step 1</b> Cut on the proper pipe diameter marked on the flashing.</p> 	<p><b>Step 2</b> Position over pipe and slide down the pipe.</p> 	<p><b>Step 3</b> Apply polyurethane sealant to the bottom of the base.</p> 	<p><b>Step 4</b> Mold the flexible base to the panel contours.</p> 	<p><b>Step 5</b> Fasten with 1/4" x 1-1/8" drilling fastener every 1-1/2" around the base.</p> 
---	--	--	--	--

Pipe drawings provided by Triangle Fasteners

### Tools and Rules:

**Basic Equipment Required:**  
Tie-off ropes, safety harness, long level, ladders, scaffolding with approved planking, extension cords with approved ground plugs and services.

**Additional Tools:**  
Metal folding tool, hammer, chalk line, measuring tape, metal cutting tools - nibblers, drills, hacksaw, utility knife, pop-rivet gun, caulking guns, layout and combination square, C clamps, sheet metal shears (including RH, LH, straight and overhand). Power driven screw gun with proper bits, depth-setting nosepiece, variable speed.

**Choose the correct equipment and tools to do the job in a safe manner. Wear safety gear and follow OSHA requirements.**

### Follow these simple rules:

1. Never cut the panels with an abrasive cut-off wheel or torch, as this will damage the finish.
2. Do not weld the trim or panels.
3. Remove any small burrs left by cutting, screwing or drilling.
4. Remove protective masking immediately after trim is installed.
5. Caution should be taken when unloading the panels to prevent damage.
6. Use appropriate screws for the type of underlayment and long enough to fully penetrate and secure the panel.
7. The stored materials should be kept dry.
8. Do not cut on finished roof. Remove all drill spirals, chips and dust immediately.
9. Seal neoprene closures and soft cell foam by applying appropriate sealant to both surfaces.
10. Put appropriate sealant/butyl tape between overlapping trims.
11. Overlap trims in a manner not to impede the flow of water.

**For further information or assistance, contact our Residential Product Support at 877-286-3320**