



# Edge-Lok Fascia - Order/Specification Form

(FOR SINGLE-PLY MEMBRANE)

## ATAS International, Inc.

Allentown, PA ~ Mesa, AZ ~ Maryville, TN  
800.468.1441 ~ info@atas.com ~ www.atas.com  
Fax: Allentown-610.395.9342 ~ Mesa-480.558.7217

COMPANY NAME: \_\_\_\_\_

PROJECT NAME: \_\_\_\_\_

CONTACT NAME: \_\_\_\_\_

LOCATION: \_\_\_\_\_

PHONE: \_\_\_\_\_

SHIP TO: \_\_\_\_\_

FAX: \_\_\_\_\_

DATE: \_\_\_\_\_

**FACTORY MUTUAL APPROVED  
ANSI/SPRI ES-1 TESTED**

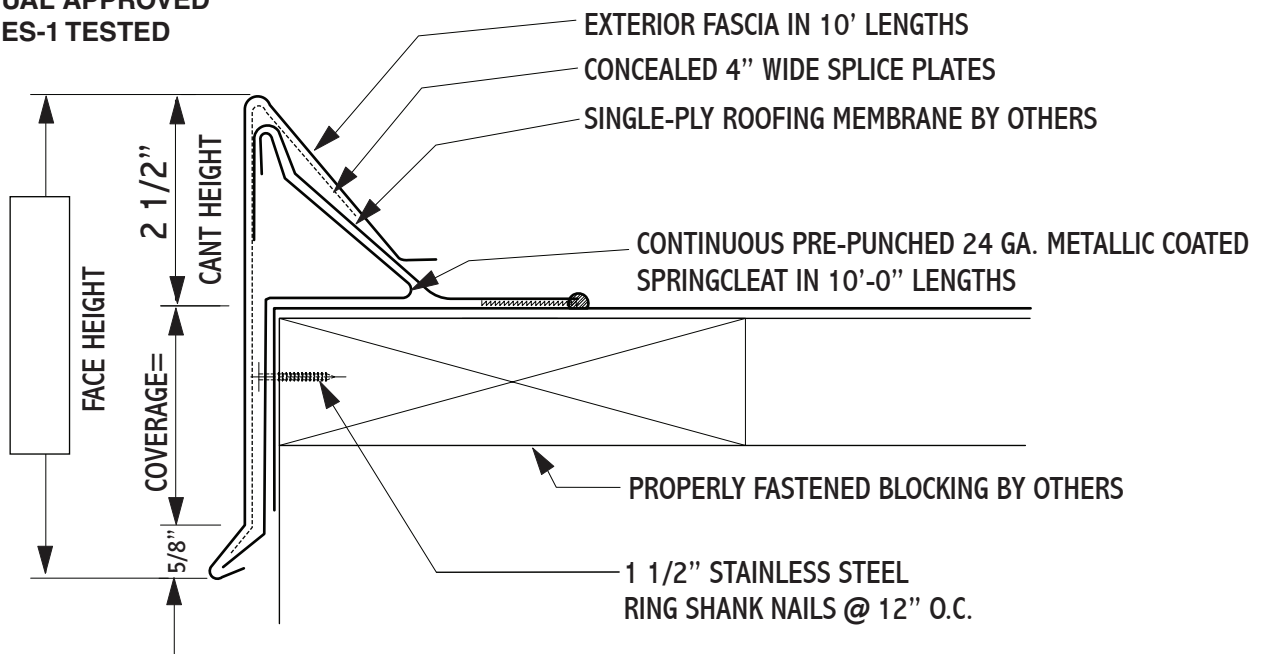

### QUANTITY

- \_\_\_\_\_ NUMBER OF PIECES
- \_\_\_\_\_ OUTSIDE CORNERS
- \_\_\_\_\_ INSIDE CORNERS
- \_\_\_\_\_ END CAP - L
- \_\_\_\_\_ END CAP - R
- \_\_\_\_\_ END TERM - L
- \_\_\_\_\_ END TERM - R
- \_\_\_\_\_ RADIUS LF
- \_\_\_\_\_ SUMPS
- \_\_\_\_\_ SPILLOUTS

### TRANSMITTAL

- REQUEST FOR QUOTATION
- SUBMIT FOR APPROVAL
- REQUEST FOR INFORMATION
- CONFIRMING TELECONFERENCE
- FOR YOUR FILES

BY \_\_\_\_\_ DATE \_\_\_\_\_

### MATERIALS

- ALUMINUM
- METALLIC COATED STEEL

### THICKNESS

- .050
- 24 GA.

### ACCESSORY TYPE

- WELDED (AL ONLY)
- METAL-LOK

\* IF ACCESSORY TYPE IS NOT CHECKED, WE WILL ASSUME "METAL-LOK"

COLOR \_\_\_\_\_

### FINISH

- PREFINISHED KYNAR
- PREFINISHED CLEAR ANODIZED (Aluminum Only)

### CUSTOMER APPROVAL

\_\_\_\_\_  
AUTHORIZED CUSTOMER SIGNATURE

\_\_\_\_\_  
PRINT NAME

\_\_\_\_\_  
TITLE

\_\_\_\_\_  
DATE

# Edge-Lok Fascia for Single-Ply Roofing

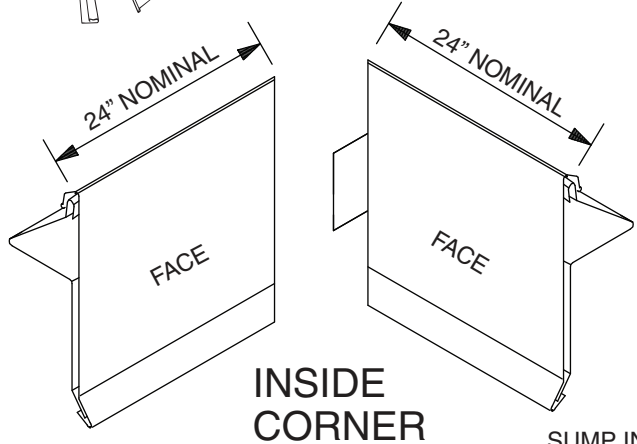

**INSIDE CORNER**

SKU	FACE HEIGHT IN.	MAX. NAILER THICKNESS COVERED IN.
<input type="checkbox"/> MAE550	5 1/2	2 1/4
<input type="checkbox"/> MAE700	7	3 3/4
<input type="checkbox"/> MAE850	8 1/2	5 1/4

SUMP INCLUDES A 1" STARTER HOLE TO ALLOW FOR FIELD CUTTING TO CORRECT SIZE OF OUTLET TUBE.

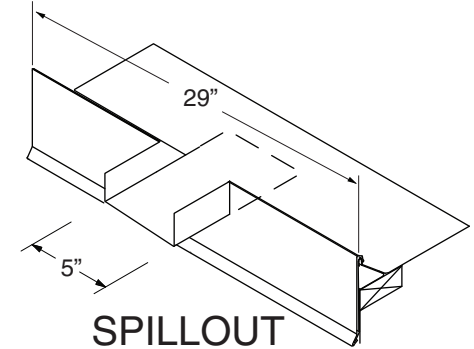

**SPILLOUT SCUPPER**

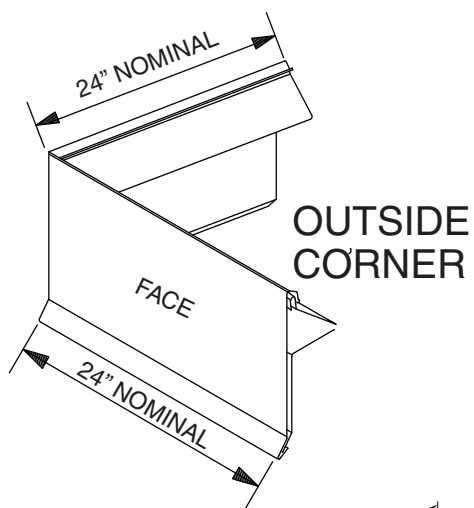

**OUTSIDE CORNER**

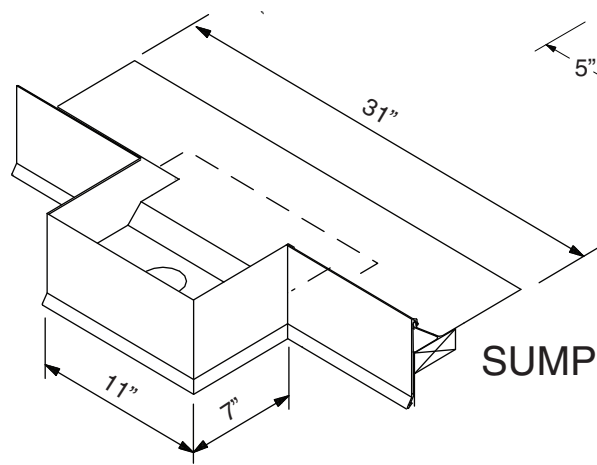

**SUMP**

SUMP AND SPILLOUT PROVIDED IN TWO PIECES FOR ON-SITE ASSEMBLY

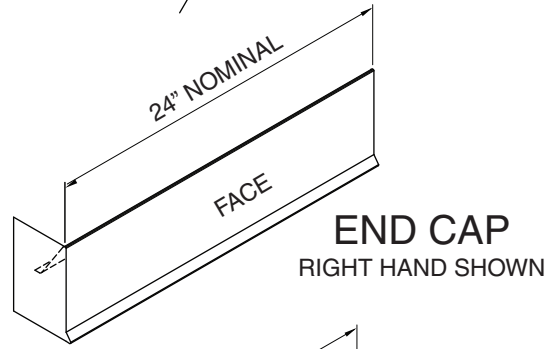

**END CAP**  
RIGHT HAND SHOWN

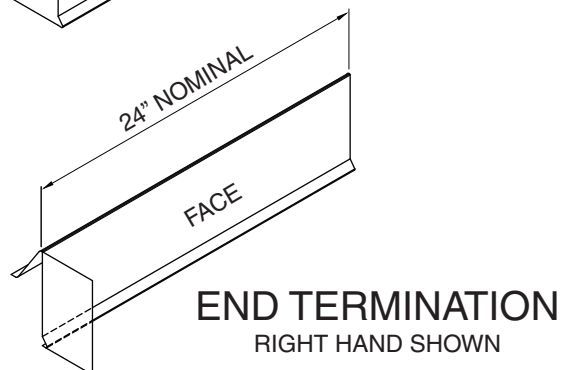

**END TERMINATION**  
RIGHT HAND SHOWN

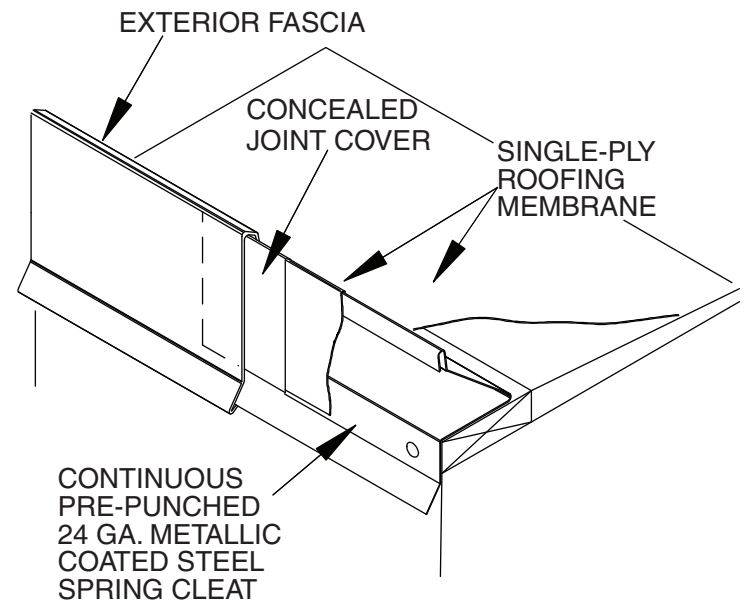

NOTE: VERIFY ALL INSTALLATION DETAILS FOR ACCEPTANCE BY MEMBRANE MANUFACTURER

## ATAS International, Inc.

Allentown, PA ~ Mesa, AZ ~ Maryville, TN  
 800.468.1441 ~ info@atas.com ~ www.atas.com  
 Fax: Allentown-610.395.9342 ~ Mesa-480.558.7217

KYNAR 500® PVDF is a trademark of Arkema.