

HEAD TRIM

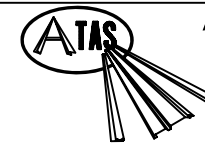

ATAS INTERNATIONAL, INC.

Allentown PA
610-395-8445
Mesa AZ
480-558-7210

TITLE BWC374 Head Deatil - panel horizontal

DWG NO. / FILE NO. BWC374 Head Horizontal SCALE 3"=1'-0"

DRAWN BY LDS DATE 8-3-07 APPR. BY DAS DATE 8-3-07

REVISION NO. XXXX REVISION DATE MM/DD/YY APPR. BY XXXX APPR. DATE MM/DD/YY

Rev. No.	Revision Date	Drawn By	Description of Revision
0	8-3-07	LDS	BWC374 Head Deatil - panel horizontal

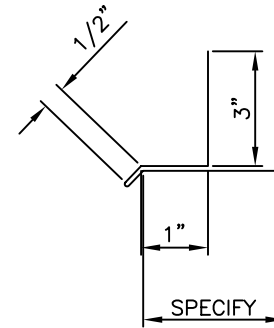
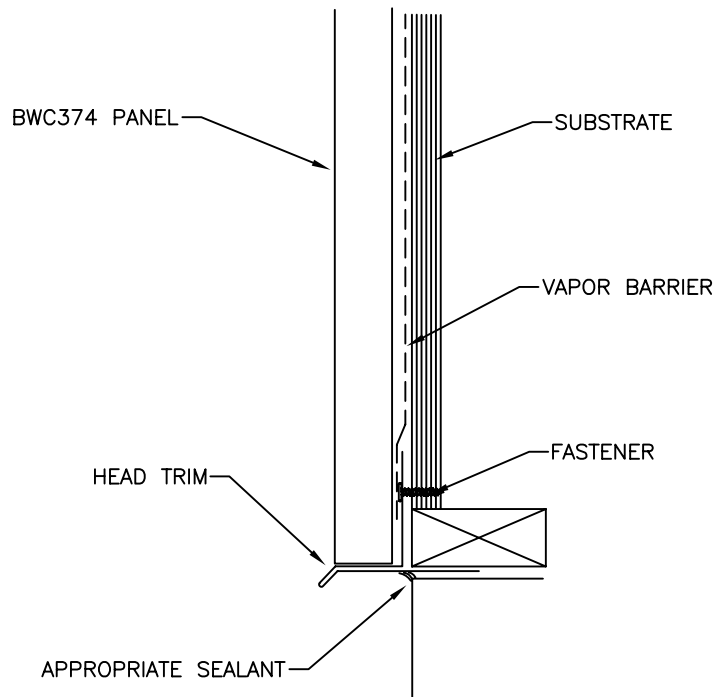

HEAD TRIM

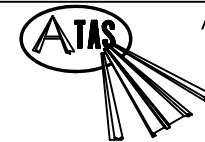

ATAS INTERNATIONAL, INC.

Allentown PA
610-395-8445
Mesa AZ
480-558-7210

TITLE		BWC374 Head Detail - panel vertical					
DWG NO. / FILE NO.		BWC Head Vertical				SCALE	3"=1'-0"
DRAWN BY	LDS	DATE	8-3-07	APPR. BY	DAS	DATE	8-3-07
REVISION NO.	XXXX	REVISION DATE	MM/DD/YY	APPR. BY	XXXX	APPR. DATE	MM/DD/YY

Rev. No.	Revision Date	Drawn By	Description of Revision
0	8-3-07	LDS	BWC374 Head Detail - panel vertical

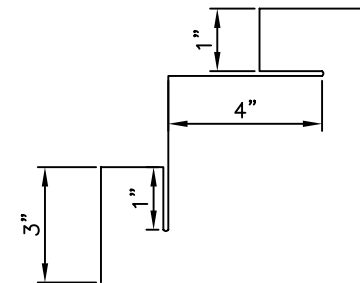
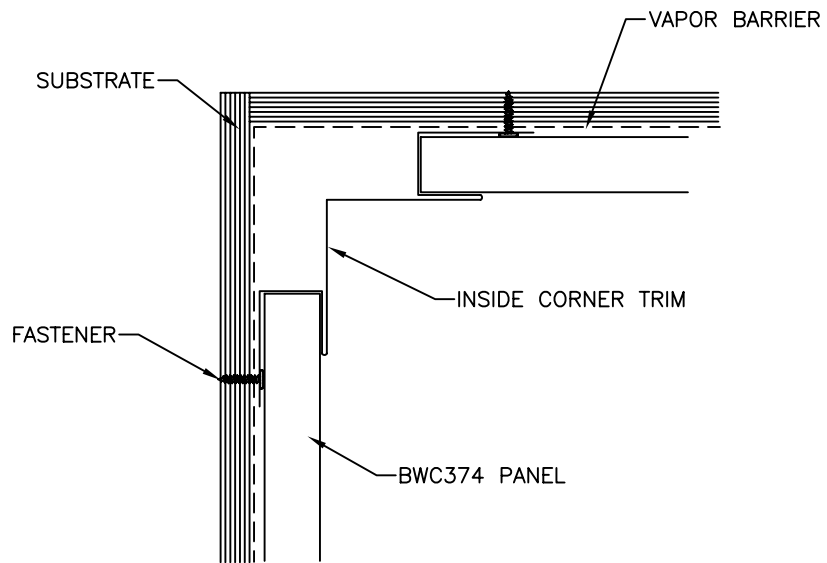

INSIDE CORNER TRIM

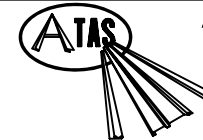

ATAS INTERNATIONAL, INC.
 Allentown PA
 610-395-8445
 Mesa AZ
 480-558-7210

TITLE BWC374 Inside Corner - panel horizontal

DWG NO. / FILE NO. BWC Inside Corner Horizontal SCALE 3"=1'-0"

DRAWN BY LDS DATE 8-3-07 APPR. BY DAS DATE 8-3-07

REVISION NO. XXXX REVISION DATE MM/DD/YY APPR. BY XXXX APPR. DATE MM/DD/YY

Rev. No.	Revision Date	Drawn By	Description of Revision
0	8-3-07	LDS	BWC374 Inside Corner - panel horizontal

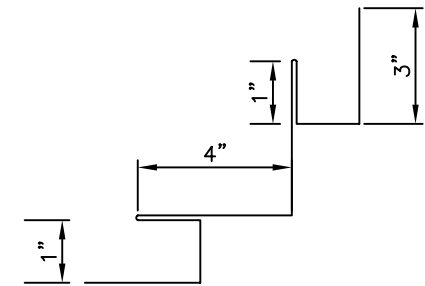
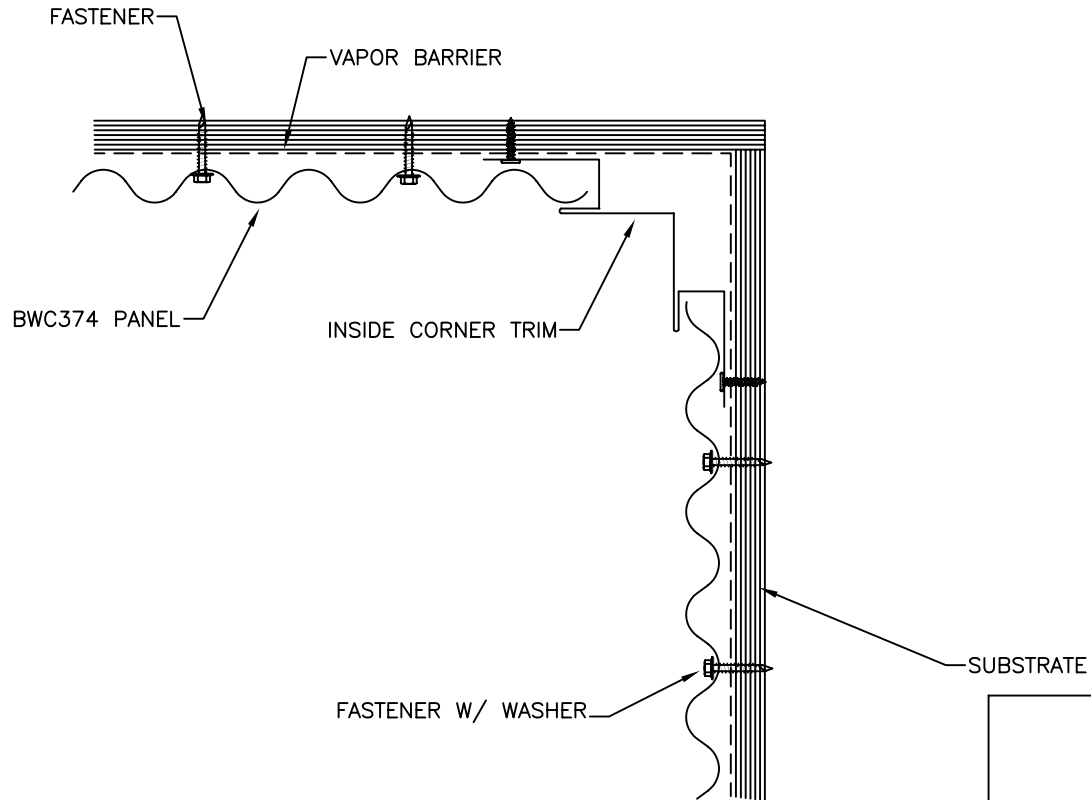

INSIDE CORNER TRIM

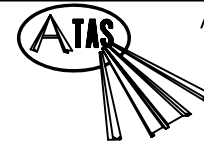

ATAS INTERNATIONAL, INC.
 Allentown PA
 610-395-8445
 Mesa AZ
 480-558-7210

TITLE BWC374 Inside Corner - panel vertical

DWG NO. / FILE NO. BWC Inside Comer Vertical SCALE 3"=1'-0"

DRAWN BY LDS DATE 8-3-07 APPR. BY DAS DATE 8-3-07

REVISION NO. XXXX REVISION DATE MM/DD/YY APPR. BY XXXX APPR. DATE MM/DD/YY

Rev. No.	Revision Date	Drawn By	Description of Revision
0	8-3-07	LDS	BWC374 Inside Corner - panel vertical

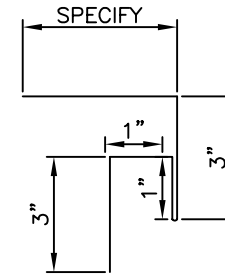
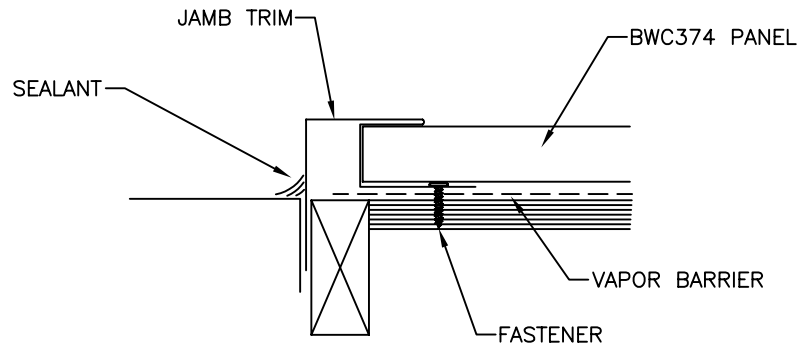

JAMB TRIM

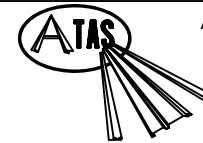

ATAS INTERNATIONAL, INC.

Allentown PA
610-395-8445
Mesa AZ
480-558-7210

TITLE		BWC374 Jamb Detail - panel horizontal			
-------	--	---------------------------------------	--	--	--

DWG NO. / FILE NO.		BWC Jamb Horizontal			SCALE	3"=1'-0"
--------------------	--	---------------------	--	--	-------	----------

DRAWN BY	LDS	DATE	8-3-07	APPR. BY	DAS	DATE	8-3-07
----------	-----	------	--------	----------	-----	------	--------

REVISION NO.	XXXX	REVISION DATE	MM/DD/YY	APPR. BY	XXXX	APPR. DATE	MM/DD/YY
--------------	------	---------------	----------	----------	------	------------	----------

Rev. No.	Revision Date	Drawn By	Description of Revision
0	8-3-07	LDS	BWC374 Jamb Detail - panel horizontal

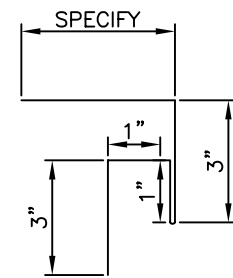
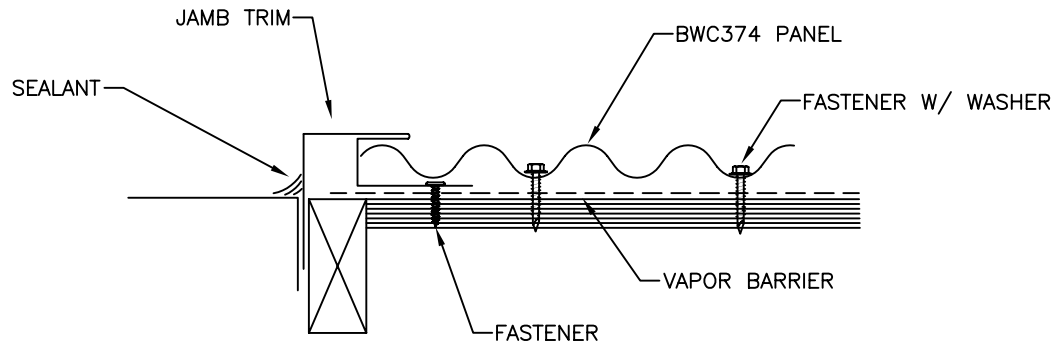

JAMB TRIM

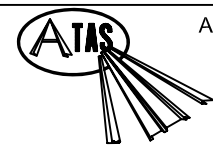

ATAS INTERNATIONAL, INC.
 Allentown PA
 610-395-8445
 Mesa AZ
 480-558-7210

TITLE		BWC374 Jamb Detail - panel vertical					
DWG NO. / FILE NO.		BWC Jamb vertical				SCALE	3"=1'-0"
DRAWN BY	LDS	DATE	8-3-07	APPR. BY	DAS	DATE	8-3-07
REVISION NO.	XXXX	REVISION DATE	MM/DD/YY	APPR. BY	XXXX	APPR. DATE	MM/DD/YY

Rev. No.	Revision Date	Drawn By	Description of Revision
0	8-3-07	LDS	BWC374 Jamb Detail - panel vertical

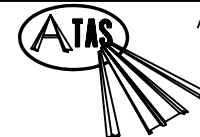
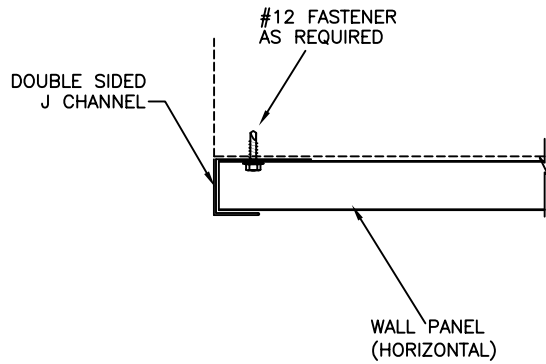

ATAS INTERNATIONAL, INC.
 Allentown PA
 610-395-8445
 Mesa AZ
 480-558-7210

TITLE **BWC J - horizontal**

DWG NO. / FILE NO. **BWC J - horizontal**

SCALE **3"=1'-0"**

Rev. No.	Revision Date	Drawn By	Description of Revision	DRAWN BY	DAS	DATE	3-6-06	APPR. BY	JEB	DATE	5-30-06
0	5-30-06	DAS	BWC J - Horizontal	REVISION NO.	XXXX	REVISION DATE	MM/DD/YY	APPR. BY	XXXX	APPR. DATE	MM/DD/YY

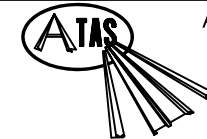
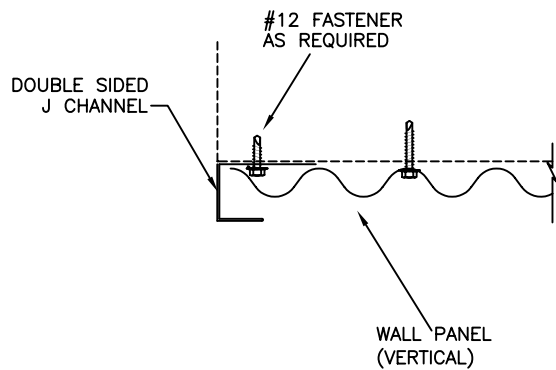

ATAS INTERNATIONAL, INC.
 Allentown PA
 610-395-8445
 Mesa AZ
 480-558-7210

TITLE		BWC J - Vertical					
DWG NO. / FILE NO.		BWC J - Vertical				SCALE	3"=1'-0"
DRAWN BY	DAS	DATE	3-6-06	APPR. BY	JEB	DATE	5-30-06
REVISION NO.	XXXX	REVISION DATE	MM/DD/YY	APPR. BY	XXXX	APPR. DATE	MM/DD/YY

Rev. No.	Revision Date	Drawn By	Description of Revision
0	5-30-06	DAS	BWC J - Vertical

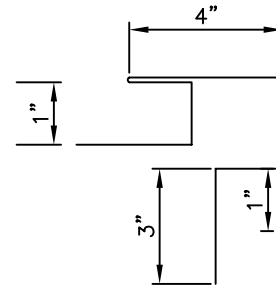
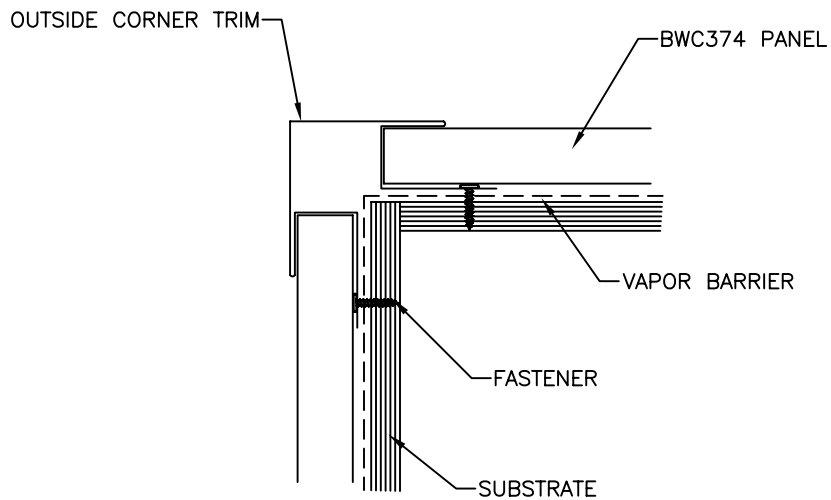

OUTSIDE CORNER TRIM

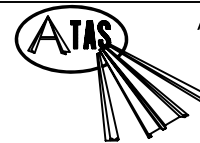

ATAS INTERNATIONAL, INC.

Allentown PA
610-395-8445
Mesa AZ
480-558-7210

TITLE BWC374 Outside Corner - panel horizontal

DWG NO. / FILE NO. BWC Outside Corner Horizontal SCALE 3"=1'-0"

DRAWN BY LDS DATE 8-3-07 APPR. BY DAS DATE 8-3-07

REVISION NO. XXXX REVISION DATE MM/DD/YY APPR. BY XXXX APPR. DATE MM/DD/YY

Rev. No.	Revision Date	Drawn By	Description of Revision
0	8-3-07	LDS	BWC374 Outside Corner - panel horizontal

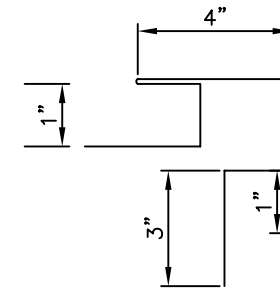
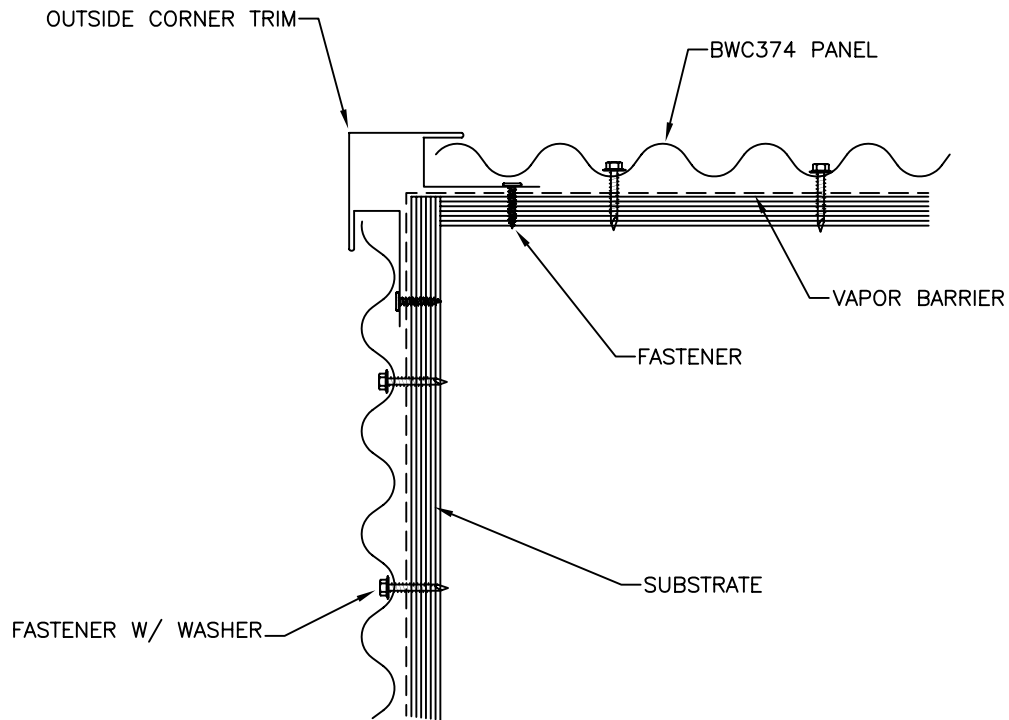

OUTSIDE CORNER TRIM

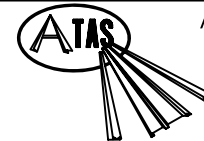

ATAS INTERNATIONAL, INC.
 Allentown PA
 610-395-8445
 Mesa AZ
 480-558-7210

TITLE BWC374 Outside Corner - panel vertical

DWG NO. / FILE NO. BWC Outside Corner Vertical SCALE 3"=1'-0"

DRAWN BY LDS DATE 8-3-07 APPR. BY DAS DATE 8-3-07

REVISION NO. XXXX REVISION DATE MM/DD/YY APPR. BY XXXX APPR. DATE MM/DD/YY

Rev. No.	Revision Date	Drawn By	Description of Revision
0	8-3-07	LDS	BWC374 Outside Corner - panel vertical

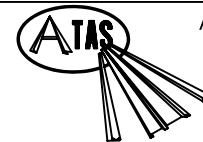
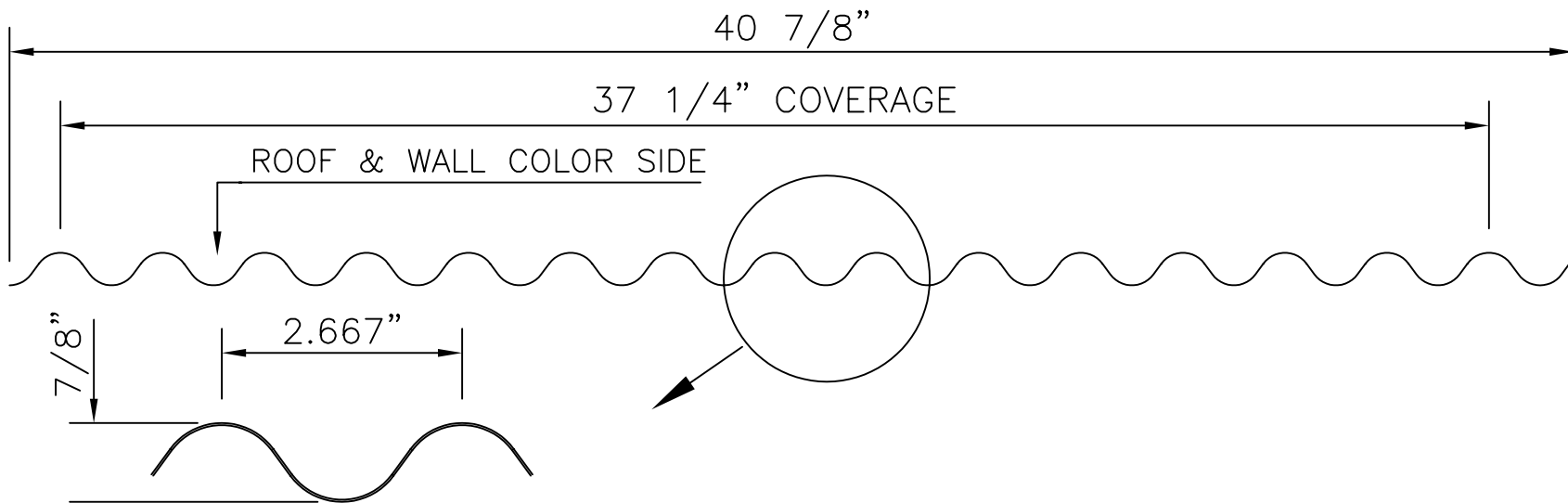

ATAS INTERNATIONAL, INC.
 Allentown PA
 610-395-8445
 Mesa AZ
 480-558-7210

TITLE		BWC Profile					
DWG NO. / FILE NO.		BWC Profile				SCALE	3"=1'-0"
DRAWN BY	DAS	DATE	8-3-07	APPR. BY	JEB	DATE	8-3-07
REVISION NO.	XXXX	REVISION DATE	MM/DD/YY	APPR. BY	XXXX	APPR. DATE	MM/DD/YY

Rev. No.	Revision Date	Drawn By	Description of Revision
0	8-3-07	DAS	BWC Profile

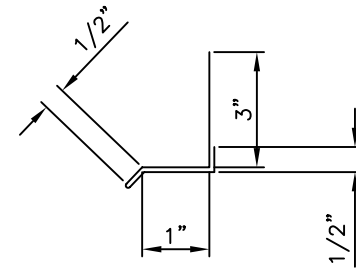
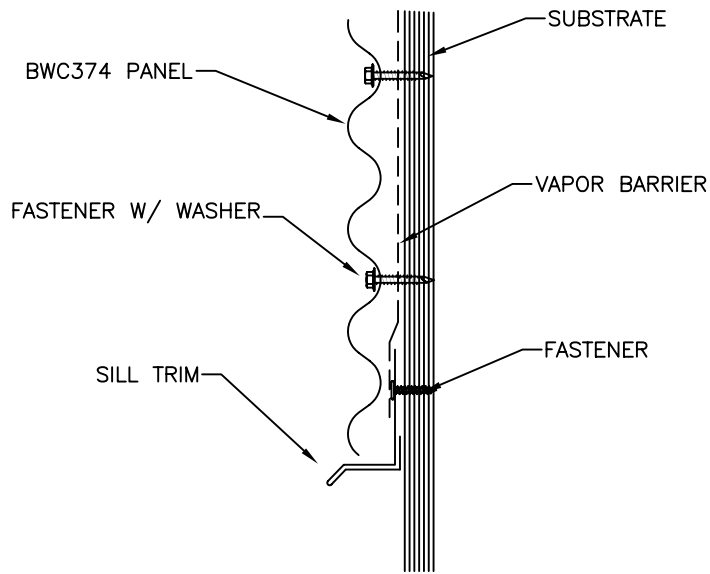

SILL TRIM

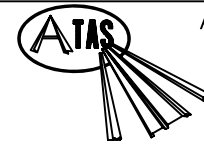

ATAS INTERNATIONAL, INC.
 Allentown PA
 610-395-8445
 Mesa AZ
 480-558-7210

TITLE								BWC374 Sill Deatil - panel horizontal							
DWG NO. / FILE NO.						BWC374 Sill Horizontal				SCALE		3"=1'-0"			
DRAWN BY		LDS		DATE		8-3-07		APPR. BY		DAS		DATE		8-3-07	
REVISION NO.		XXXX		REVISION DATE		MM/DD/YY		APPR. BY		XXXX		APPR. DATE		MM/DD/YY	

Rev. No.	Revision Date	Drawn By	Description of Revision
0	8-3-07	LDS	BWC374 Sill Deatil - panel horizontal

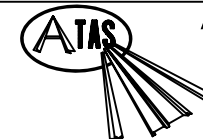
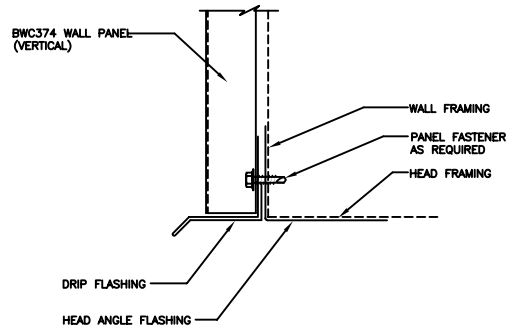

ATAS INTERNATIONAL, INC.
 Allentown PA
 610-395-8445
 Mesa AZ
 480-558-7210

TITLE										BWC sill - vertical							
DWG NO. / FILE NO.										BWC sill - vertical				SCALE		3"=1'-0"	
DRAWN BY		DAS		DATE		3-6-06		APPR. BY		JEB		DATE		5-30-06			
REVISION NO.		XXXX		REVISION DATE		MM/DD/YY		APPR. BY		XXXX		APPR. DATE		MM/DD/YY			

Rev. No.	Revision Date	Drawn By	Description of Revision
0	5-30-06	DAS	BWC sill - vertical

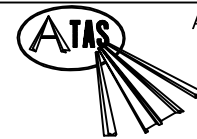
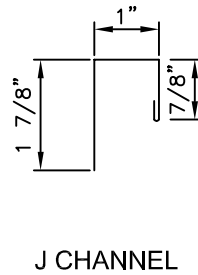
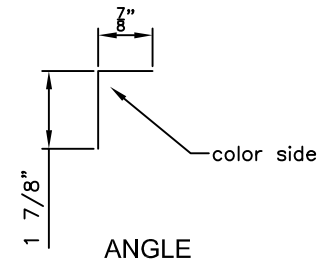
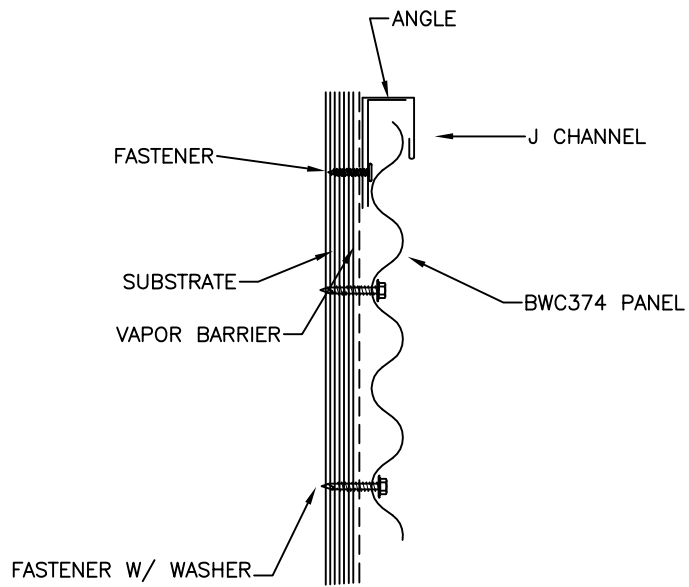

ATAS INTERNATIONAL, INC.
 Allentown PA
 610-395-8445
 Mesa AZ
 480-558-7210

TITLE		BWC374 Top Detail - panel horizontal					
DWG NO. / FILE NO.		BWC Top Horizontal				SCALE	3"=1'-0"
DRAWN BY	LDS	DATE	8-3-07	APPR. BY	DAS	DATE	8-3-07
REVISION NO.	XXXX	REVISION DATE	MM/DD/YY	APPR. BY	XXXX	APPR. DATE	MM/DD/YY

Rev. No.	Revision Date	Drawn By	Description of Revision
0	8-3-07	LDS	BWC374 Top Detail - panel horizontal

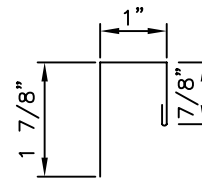
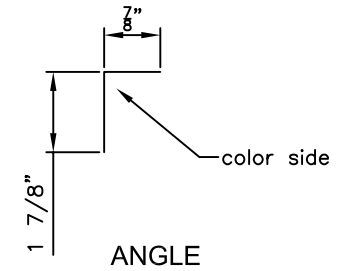
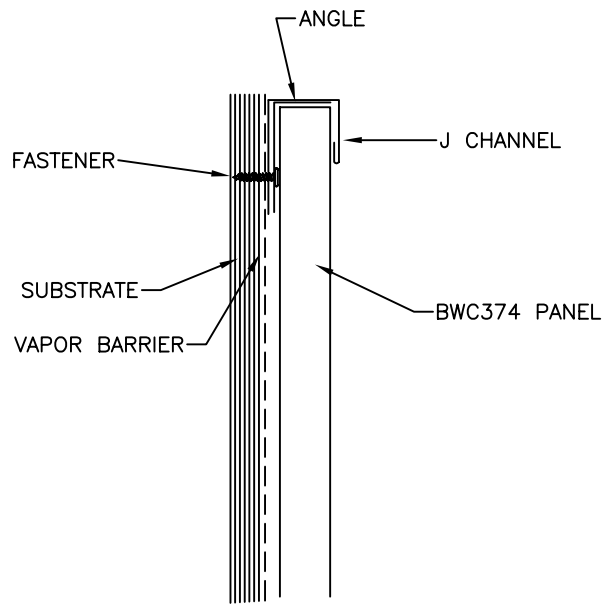

J CHANNEL (DSA158)

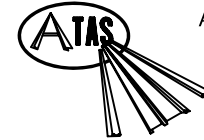

ATAS INTERNATIONAL, INC.
Allentown PA
610-395-8445
Mesa AZ
480-558-7210

TITLE		BWC374 Top Detail - panel vertical					
DWG NO. / FILE NO.		BWC Top Vertical				SCALE	3"=1'-0"
DRAWN BY	LDS	DATE	8-3-07	APPR. BY	DAS	DATE	8-3-07
REVISION NO.	XXXX	REVISION DATE	MM/DD/YY	APPR. BY	XXXX	APPR. DATE	MM/DD/YY

Rev. No.	Revision Date	Drawn By	Description of Revision
0	8-3-07	LDS	BWC374 Top Detail - panel vertical

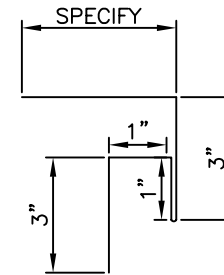
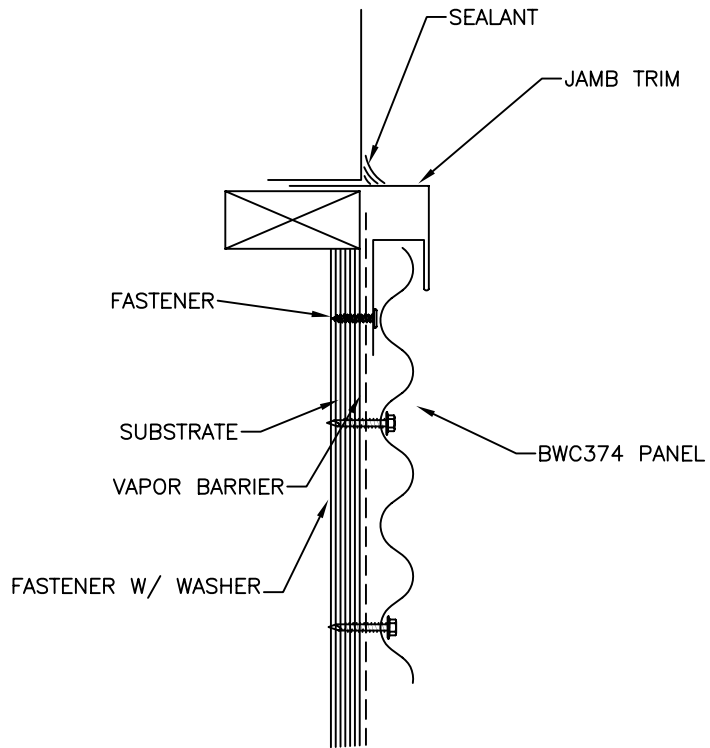

JAMB TRIM

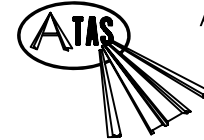

ATAS INTERNATIONAL, INC.
 Allentown PA
 610-395-8445
 Mesa AZ
 480-558-7210

TITLE BWC374 Window Sill Detail - panel horizontal

DWG NO. / FILE NO. BWC Window Sill Horizontal SCALE 3"=1'-0"

DRAWN BY LDS DATE 8-3-07 APPR. BY DAS DATE 8-3-07

REVISION NO. XXXX REVISION DATE MM/DD/YY APPR. BY XXXX APPR. DATE MM/DD/YY

Rev. No.	Revision Date	Drawn By	Description of Revision
0	8-3-07	LDS	BWC374 Window Sill Detail - panel horizontal

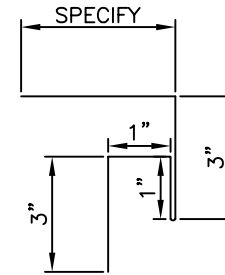
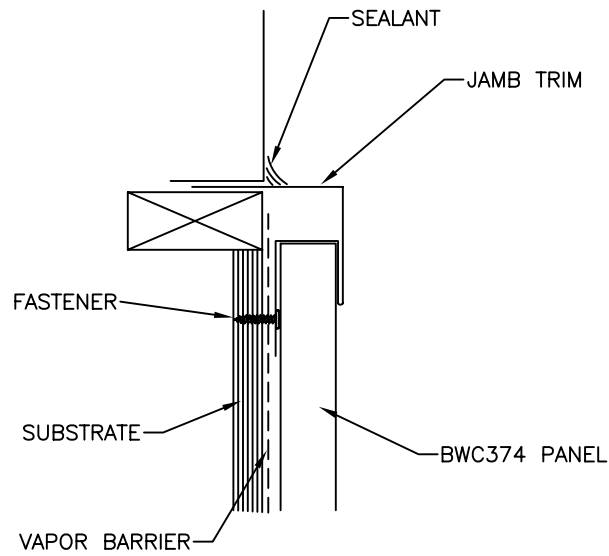

JAMB TRIM

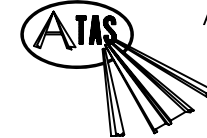

ATAS INTERNATIONAL, INC.
 Allentown PA
 610-395-8445
 Mesa AZ
 480-558-7210

TITLE		BWC374 Window Sill Detail - panel Vertical					
DWG NO. / FILE NO.		BWC Window Sill Vertical				SCALE	3"=1'-0"
DRAWN BY	LDS	DATE	8-3-07	APPR. BY	DAS	DATE	8-3-07
REVISION NO.	XXXX	REVISION DATE	MM/DD/YY	APPR. BY	XXXX	APPR. DATE	MM/DD/YY

Rev. No.	Revision Date	Drawn By	Description of Revision
0	8-3-07	LDS	BWC374 Window Sill Detail - panel Vertical