

ATAS INTERNATIONAL, INC.  
 Allentown PA  
 610-395-8445  
 Mesa AZ  
 480-558-7210

TITLE		DWF Inside Corner					
DWG NO. / FILE NO.		DWF Inside Corner				SCALE	3"=1'-0"
DRAWN BY	DAS	DATE	3-6-06	APPR. BY	JEB	DATE	5-30-06
REVISION NO.	XXXX	REVISION DATE	MM/DD/YY	APPR. BY	XXXX	APPR. DATE	MM/DD/YY

Rev. No.	Revision Date	Drawn By	Description of Revision
0	5-30-06	DAS	DWF Inside Corner

FIELD BEND PANEL FOR  
COMPRESSION FIT IN  
POCKET OF CORNER.

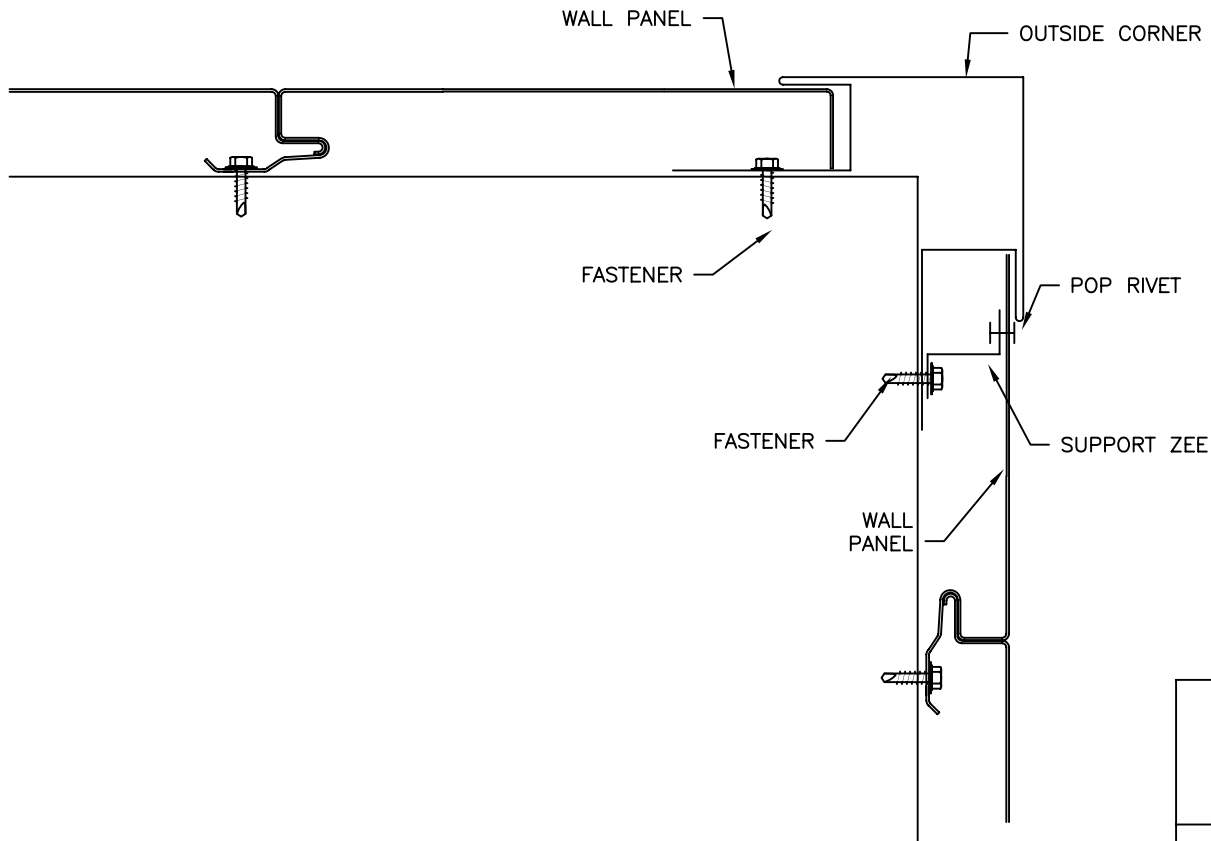

USE ZEE CHANNEL  
AS REQUIRED TO COMPRESSION  
FIT PANEL IN POCKET OF  
CORNER FLASHING. POP  
RIVET AS NECESSARY.

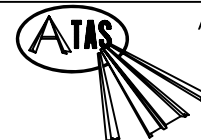

ATAS INTERNATIONAL, INC.  
Allentown PA  
610-395-8445  
Mesa AZ  
480-558-7210

TITLE DWF Outside Corner

DWG NO. / FILE NO. DWF Outside Corner SCALE 3"=1'-0"

DRAWN BY DAS DATE 3-6-06 APPR. BY JEB DATE 5-30-06

REVISION NO. XXXX REVISION DATE MM/DD/YY APPR. BY XXXX DATE MM/DD/YY

Rev. No.	Revision Date	Drawn By	Description of Revision
0	5-30-06	DAS	DWF Outside Corner

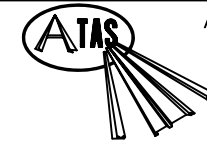
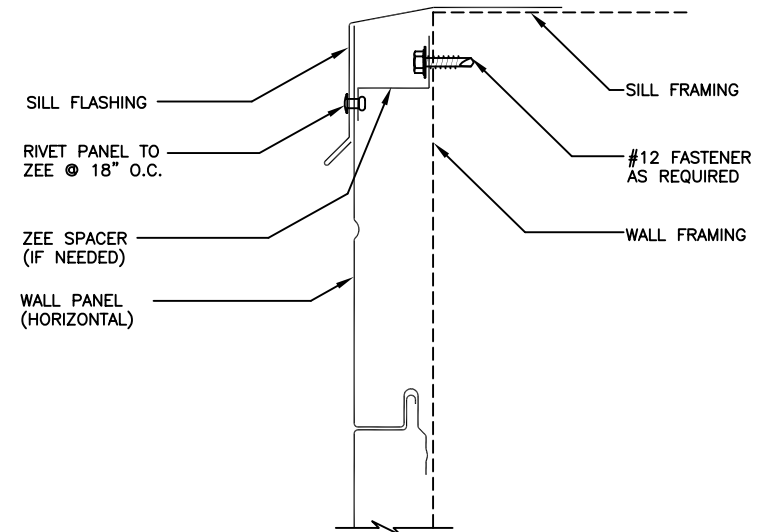
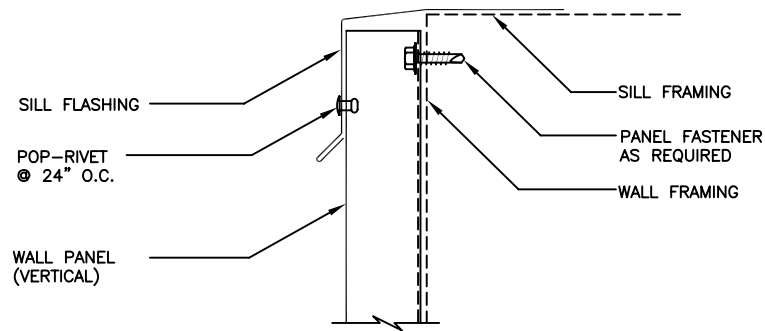

ATAS INTERNATIONAL, INC.  
 Allentown PA  
 610-395-8445  
 Mesa AZ  
 480-558-7210

TITLE		DWF Sill					
DWG NO. / FILE NO.		DWF Sill				SCALE	3"=1'-0"
DRAWN BY	DAS	DATE	3-6-06	APPR. BY	JEB	DATE	5-30-06
REVISION NO.	XXXX	REVISION DATE	MM/DD/YY	APPR. BY	XXXX	APPR. DATE	MM/DD/YY

Rev. No.	Revision Date	Drawn By	Description of Revision
0	5-30-06	DAS	DWF Sill

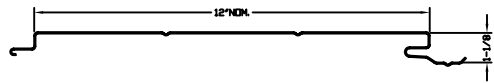

DWF120

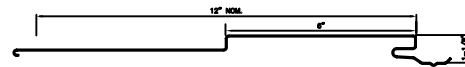

DWH120

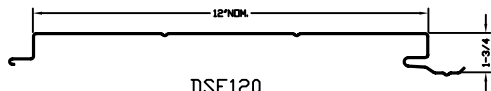

DSF120

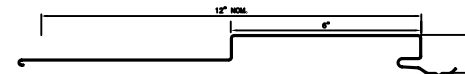

DSH120

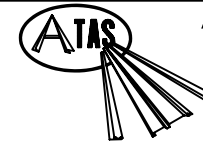
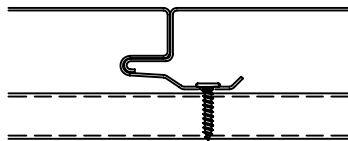
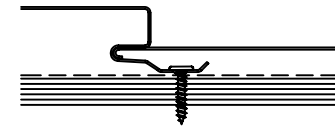

ATAS INTERNATIONAL, INC.

Allentown PA  
610-395-8445  
Mesa AZ  
480-558-7210

TITLE Design Wall Profile

DWG NO. / FILE NO. Design Wall Profile SCALE 3"=1'-0"

DRAWN BY DAS DATE 7-25-07 APPR. BY JEB DATE 7-25-07

REVISION NO. XXXX REVISION DATE MM/DD/YY APPR. BY XXXX APPR. DATE MM/DD/YY

Rev. No.	Revision Date	Drawn By	Description of Revision
0	7-25-07	DAS	Design Wall Profile

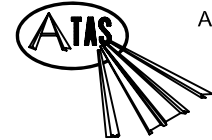
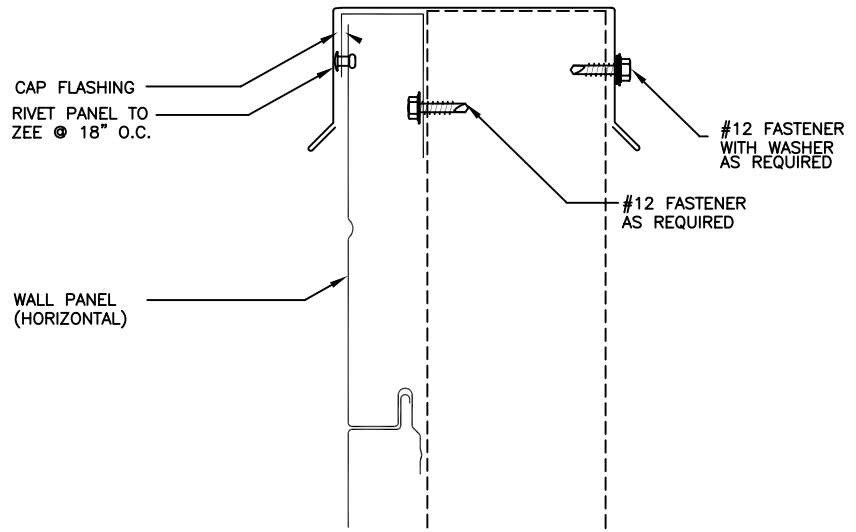

ATAS INTERNATIONAL, INC.  
 Allentown PA  
 610-395-8445  
 Mesa AZ  
 480-558-7210

TITLE		DWF Cap					
DWG NO. / FILE NO.		DWF Cap				SCALE	3"=1'-0"
DRAWN BY	DAS	DATE	3-6-06	APPR. BY	JEB	DATE	5-30-06
REVISION NO.	XXXX	REVISION DATE	MM/DD/YY	APPR. BY	XXXX	APPR. DATE	MM/DD/YY

Rev. No.	Revision Date	Drawn By	Description of Revision
0	5-30-06	DAS	DWF Cap

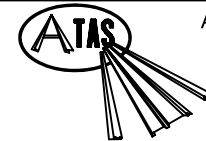
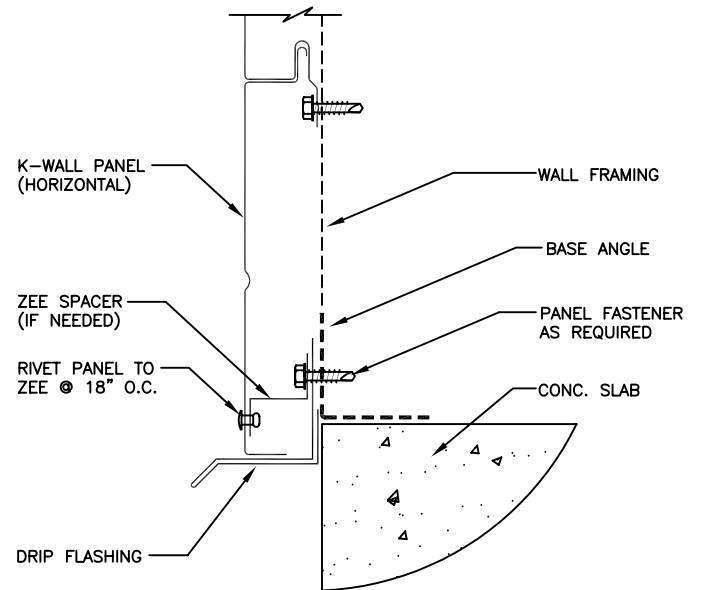
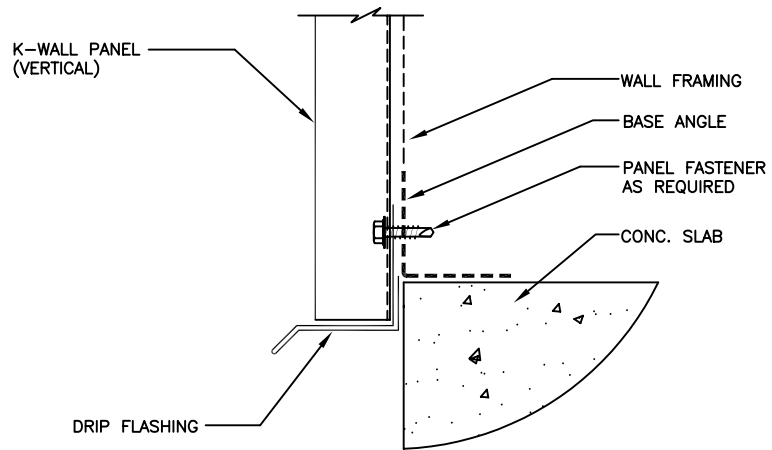

ATAS INTERNATIONAL, INC.  
 Allentown PA  
 610-395-8445  
 Mesa AZ  
 480-558-7210

TITLE		DWF Base					
DWG NO. / FILE NO.		DWF Base				SCALE	3"=1'-0"
DRAWN BY	DAS	DATE	3-6-06	APPR. BY	JEB	DATE	5-30-06
REVISION NO.	XXXX	REVISION DATE	MM/DD/YY	APPR. BY	XXXX	APPR. DATE	MM/DD/YY

Rev. No.	Revision Date	Drawn By	Description of Revision
0	5-30-06	DAS	DWF Base

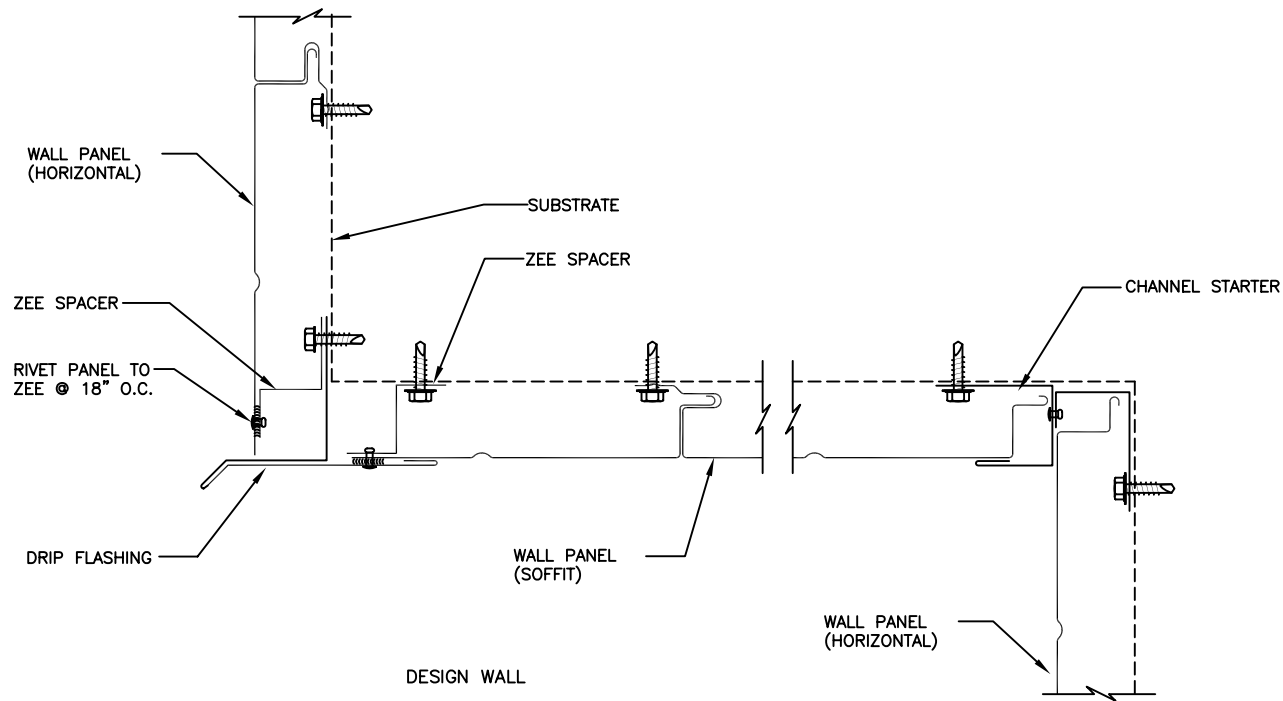

SOFFIT TO WALL DETAIL

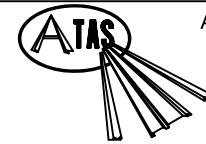

ATAS INTERNATIONAL, INC.  
 Allentown PA  
 610-395-8445  
 Mesa AZ  
 480-558-7210

TITLE		DWF Soffit to Wall					
DWG NO. / FILE NO.		DWF Soffit to Wall				SCALE	3"=1'-0"
DRAWN BY	DAS	DATE	3-6-06	APPR. BY	JEB	DATE	5-30-06
REVISION NO.	XXXX	REVISION DATE	MM/DD/YY	APPR. BY	XXXX	APPR. DATE	MM/DD/YY

Rev. No.	Revision Date	Drawn By	Description of Revision
0	5-30-06	DAS	DWF Soffit to Wall