



# Rapid-Lok Fascia - Order/Specification Form

(FOR SINGLE-PLY MEMBRANE)

## ATAS International, Inc.

Allentown, PA ~ Mesa, AZ ~ Maryville, TN  
800.468.1441 ~ info@atas.com ~ www.atas.com  
Fax: Allentown-610.395.9342 ~ Mesa-480.558.7217

COMPANY NAME: \_\_\_\_\_

PROJECT NAME: \_\_\_\_\_

CONTACT NAME: \_\_\_\_\_

LOCATION: \_\_\_\_\_

PHONE: \_\_\_\_\_

SHIP TO: \_\_\_\_\_

FAX: \_\_\_\_\_

DATE: \_\_\_\_\_

**FACTORY MUTUAL APPROVED  
ANSI/SPRI ES-1 TESTED**

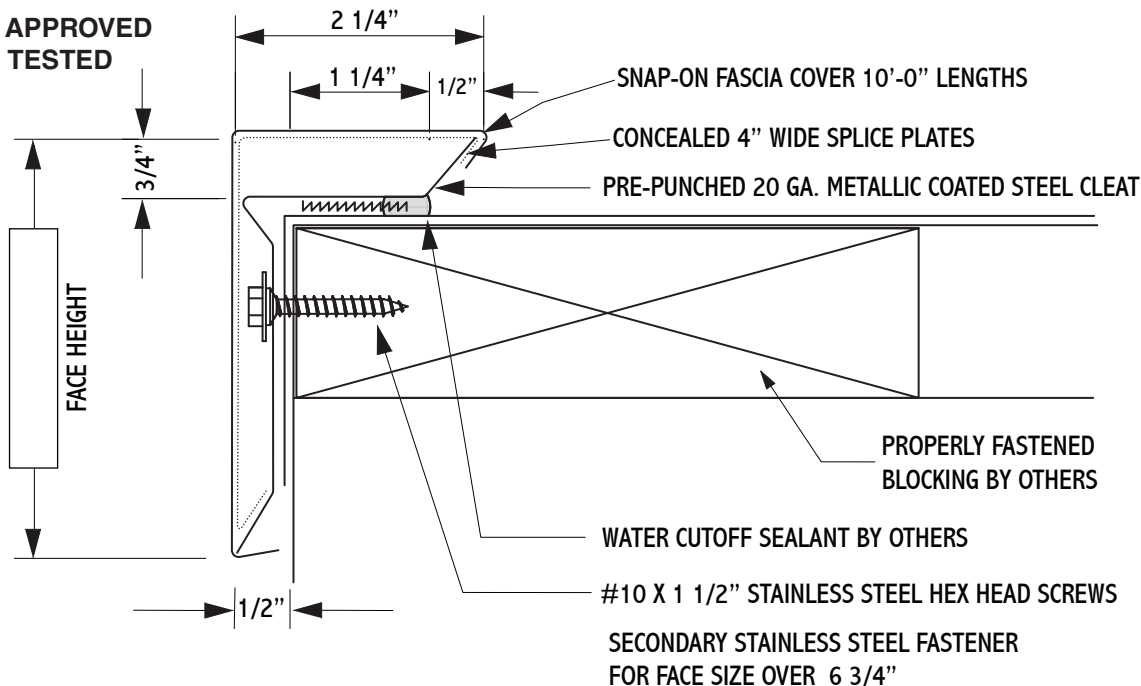

### QUANTITY

- \_\_\_\_\_ NUMBER OF PIECES
- \_\_\_\_\_ OUTSIDE CORNERS
- \_\_\_\_\_ INSIDE CORNERS
- \_\_\_\_\_ END CAP - L
- \_\_\_\_\_ END CAP - R
- \_\_\_\_\_ SUMPS
- \_\_\_\_\_ SPILLOUTS

### MATERIALS

- ALUMINUM
- METALLIC COATED STEEL

### THICKNESS

- .040
- .050
- 24 GA.

### ACCESSORY TYPE

- METAL-LOK

COLOR \_\_\_\_\_

### FINISH

- PREFINISHED KYNAR 500® PVDF
- PREFINISHED CLEAR ANODIZED (Aluminum Only)

### TRANSMITTAL

- REQUEST FOR QUOTATION
- SUBMIT FOR APPROVAL
- REQUEST FOR INFORMATION
- CONFIRMING TELECONFERENCE
- FOR YOUR FILES

BY \_\_\_\_\_ DATE \_\_\_\_\_

### CUSTOMER APPROVAL

\_\_\_\_\_  
AUTHORIZED CUSTOMER SIGNATURE

\_\_\_\_\_  
PRINT NAME

\_\_\_\_\_  
TITLE

\_\_\_\_\_  
DATE

SKU	FACE HEIGHT IN.	COVERAGE IN.
<input type="checkbox"/> MAF370	3 3/4	2 1/16
<input type="checkbox"/> MAF520	5 1/4	3 9/16
<input type="checkbox"/> MAF670	6 3/4	5 11/16
<input type="checkbox"/> MAF820	8 1/4	6 9/16

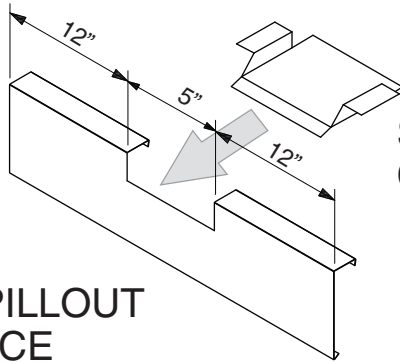

**SPILLOUT CORE**

**SPILLOUT FACE**

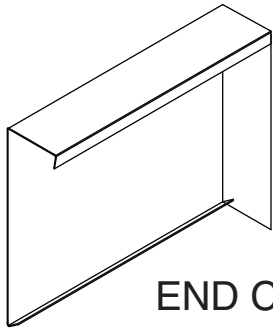

**END CAP**

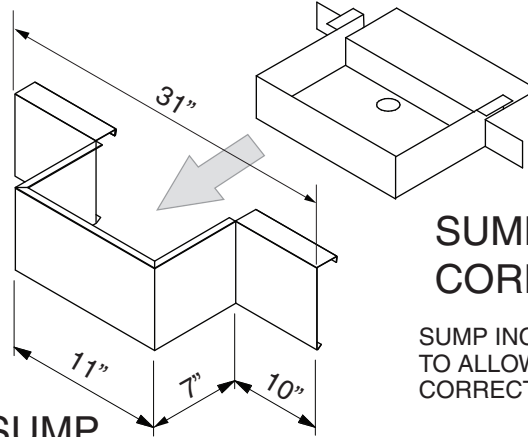

**SUMP CORE**

SUMP INCLUDES A 1" STARTER HOLE TO ALLOW FOR FIELD CUTTING TO CORRECT SIZE OF OUTLET TUBE.

**SUMP FACE**

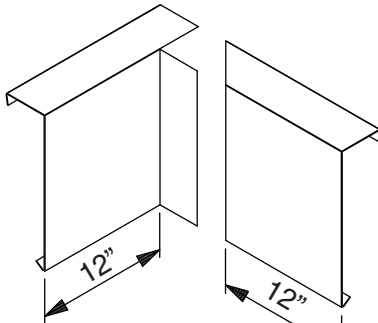

**INSIDE CORNER**

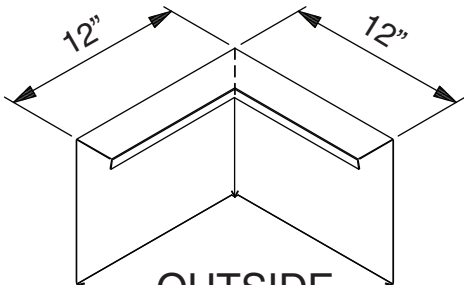

**OUTSIDE CORNER**

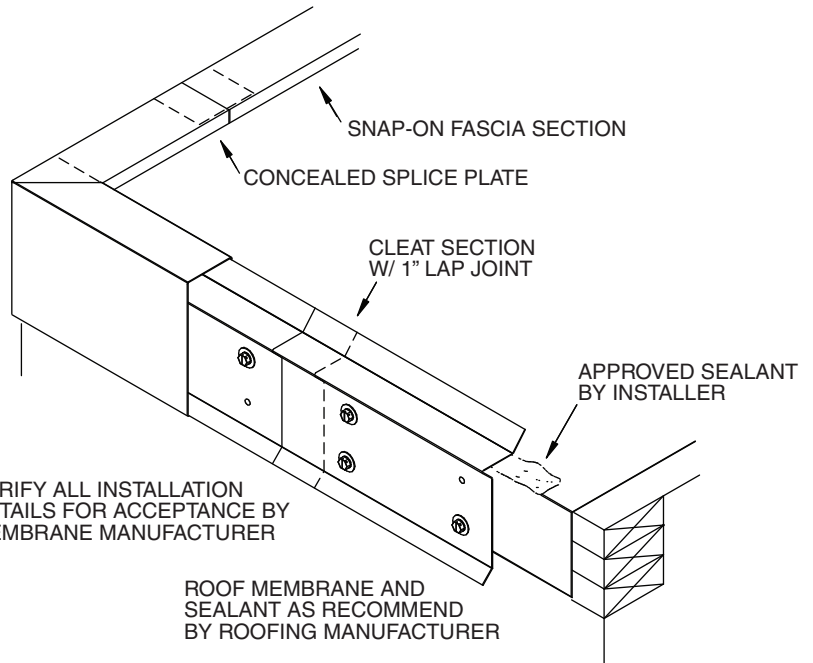

WHEN FACE SIZE EXCEEDS 6", ADDITIONAL FASTENERS ARE REQUIRED ON THE FACE OF THE CLEAT.

**ATAS International, Inc.**

Allentown, PA ~ Mesa, AZ ~ Maryville, TN  
 800.468.1441 ~ info@atas.com ~ www.atas.com  
 Fax: Allentown-610.395.9342 ~ Mesa-480.558.7217

KYNAR 500® PVDF is a trademark of Arkema.