

# PC PANEL

## Installation Guide

The PC roof panel is available in three widths ( 11-1/4", 12-5/8", and 15-1/4" with 1" Standing Seam or a 1" or 2" Batten Seam. The panels are roll formed from 16 oz. copper, .032 and .040 aluminum and 24 ga. Metallic Coated steel, smooth or stucco embossed. 22 ga. Metallic Coated steel is available, subject to minimum quantity. The material has a KYNAR 500® and/or HYLAR 5000® quality finish, in 30 standard colors. The minimum panel length is 3'-0", the maximum is determined by shipping considerations. Minimum recommended pitch is 3:12.

**Review and understand complete guide before beginning installation.**

This guide has been prepared as suggested details to particular design conditions. Each condition has certain limitations to performance, aesthetics or economics. Professionals qualified to assess this information for a specific project, should determine that the selection and installation are made to their requirements. ATAS **cannot** assume any responsibility for the actual selection and/or installation of materials. The panels, flashings and trim shown in this guide, illustrated over solid and plumb substrate, assume that the structure has been designed and prepared in accordance with local building codes.

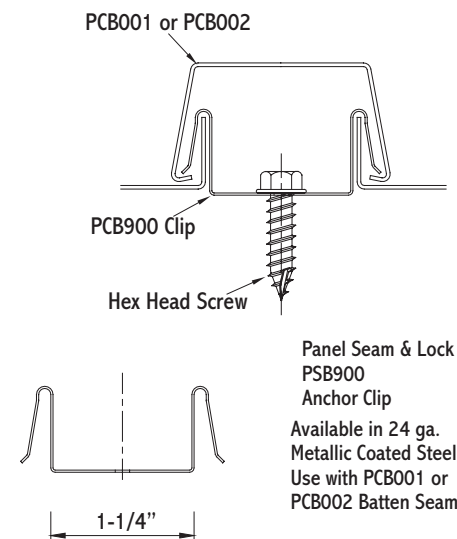
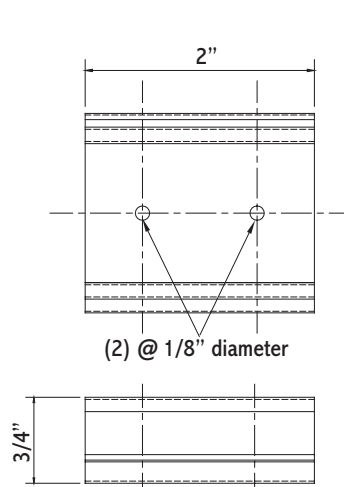
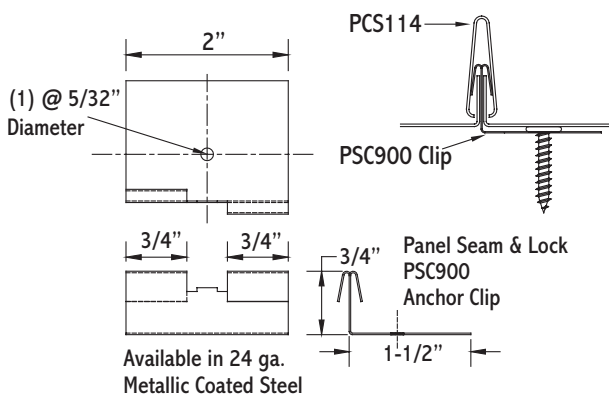
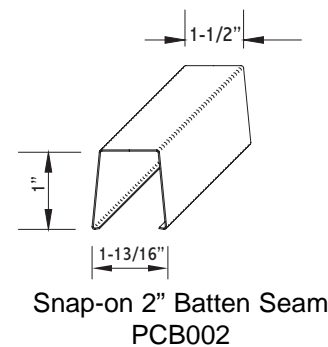
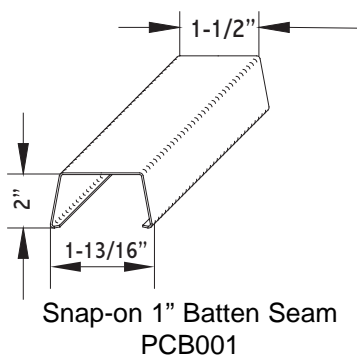
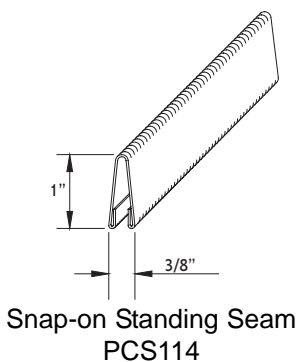
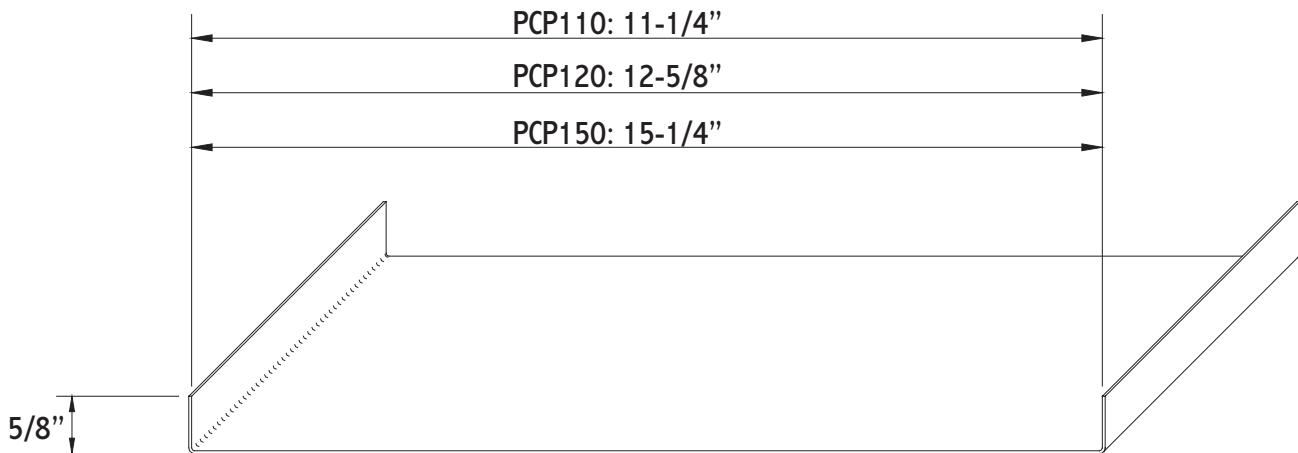

# Eave Detail

1. In re-roofing applications: cut back and remove existing shingles and drip edge to be flush with the eave and gable lines, or as required to install underlayment.
2. In all applications: apply ATA-Shield\*\* along eave and up the roof to a point at least 24" beyond outside face of exterior wall.
3. Install drip edge against fascia trim. Lay ATA-Guard\* over eave trim.
4. Trim panel and water leg back to allow for turn down. Install panel by sliding lower flanged edge over drip edge. Place clips at water leg.
5. Snap seam or batten over clips after two adjacent panels are in installed

*General Note: Before any installation be sure to lay ATA-Shield\*\* in all areas where ice & water can occur. 30# felt or appropriate underlayment should be installed over the entire roof. When asphalt based felt underlayment is used install a separate sheet, such as rosin paper, to minimize friction.*

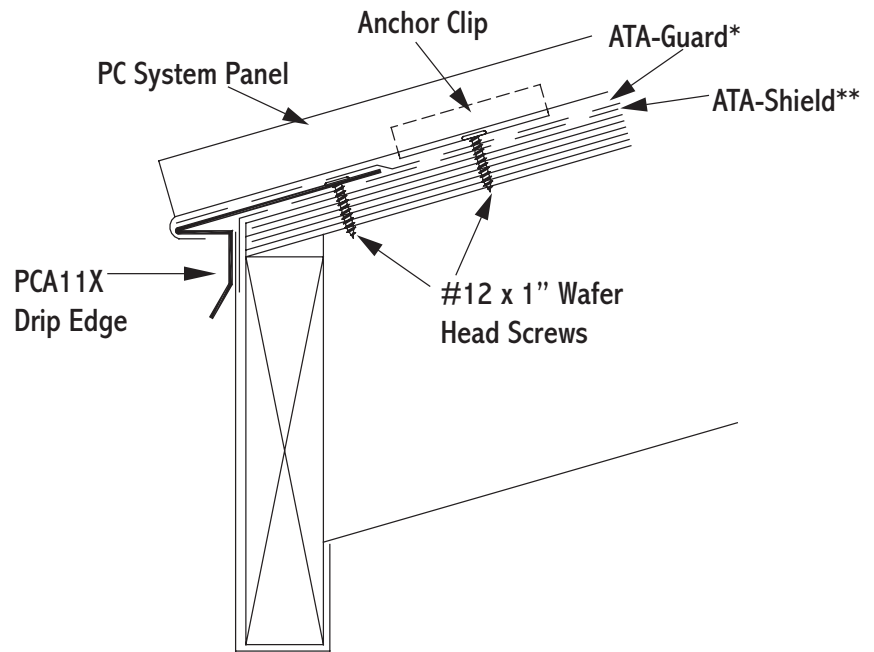

# Gable Detail

1. At gable start detail, install gable trim starter cleat with appropriate fasteners at 2'-0" into fascia board.
2. At end gable, install cut panel at end with clip. Bring other panel in and overlap under clip (see sketch). Be sure to butyl tape panel end at overlap.
3. Apply double-faced butyl sealant as circled in sketch. Fasten "Z" closure to panel with pop-rivets.
4. Install starter cleat at end detail same as start detail.
5. At both ends snap gable/rake trim over starter cleat and "Z" closure to lock into place. Pop-rivet these two pieces together with one pop-rivet per trim length.

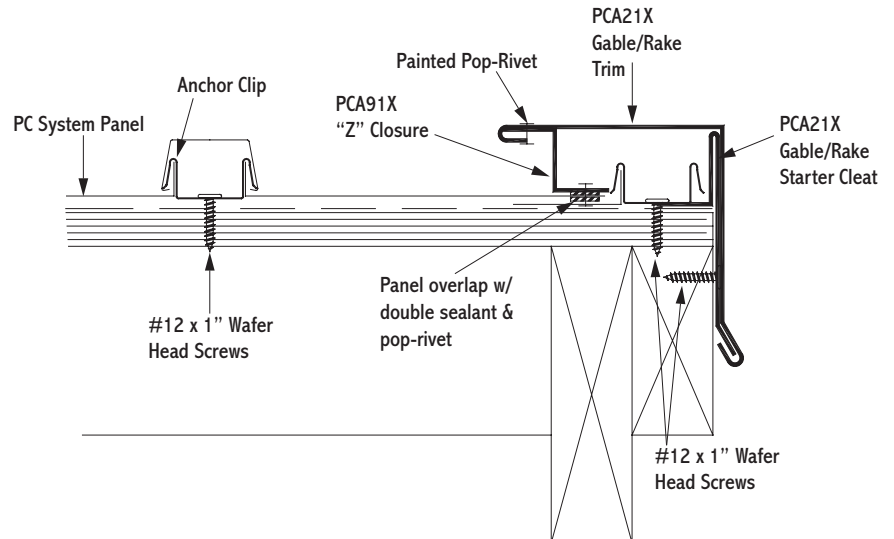

# Valley Detail

1. Install ATA-Shield\*\* approximately 18" up both side of the valley line.
2. Lay valley pan in valley center. Locate joggle cleat at 4" to 6" from valley center.
3. Install joggle cleat. Fasten 6" o.c. through butyl tape and pan into substrate.
4. Turn under edge of panel to slide into joggle cleat. Place clips at water leg.
5. Snap seam or batten over clips after two adjacent panels are in installed.

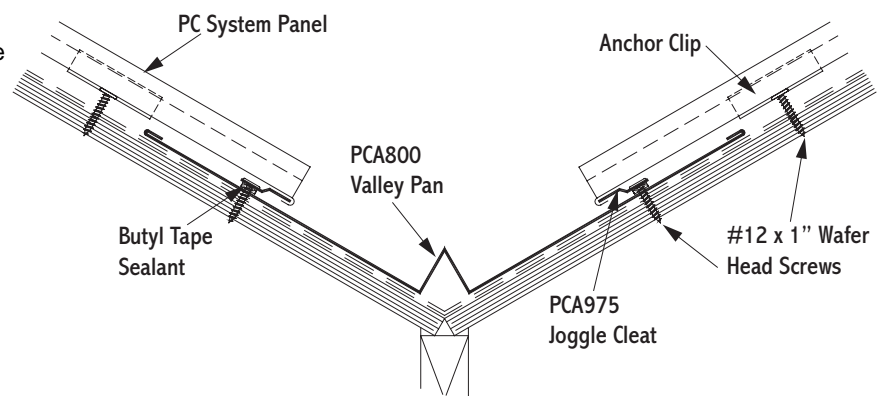

**Underlayments:** ATA-Guard\* is a polyolefin based, 100% asphalt free, high strength reinforced roofing underlayment for use on steep slopes beneath metal roofing. 1000 sq. ft. per roll at 48" wide.

**Underlayments:** ATA-Shield\*\* is the recommended self adhesive underlayment for eaves, sidewall and any critical areas exposed to ice damming and extensive water run off. Available in 65'-8" x 3' 3-8" rolls (200 sq. ft. per roll).

# Hip & Ridge Detail

Hip and ridge applications are handled in the same manner.

1. Cut "Z" closure to fit between seams and install in butyl tape.
2. Fasten "Z" closure in bed of sealant at top of panel. (Use 3 fasteners on 11 1/4" panel, 4 on 12 5/8", 5 on 15 1/4")
3. Seal neoprene strips into "Z" closures
4. Snap hip/ridge cap over "Z" closures for it to lock into place. Pop-riquet one side only to allow for expansion and contraction.

**Notes:**

- \* Trim must be pop-riqueted to Z in at least (1) location.
- \* Unless otherwise specified, all fasteners for trim components at 2'-0" o.c.
- \* Install splice plates at ridge cap joints. Pop rivet splice to one end of ridge cap to allow for expansion and contraction.

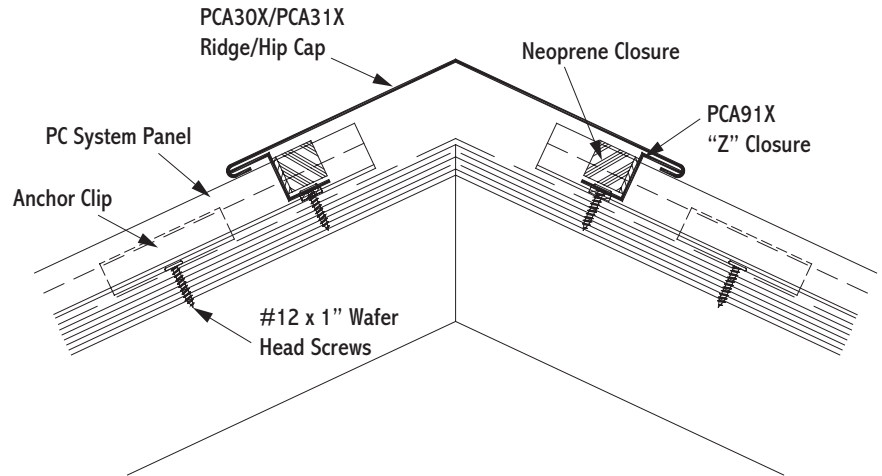

# Headwall Detail

Install appropriate underlayment to the edge.

1. In standard headwall situation (without venting), run underlayment from roof plane up headwall. Install panels up to headwall.
2. Cut "Z" closure to fit between seams and install in butyl tape.
3. Fasten "Z" closure in bed of sealant at top of panel. (Use 3 fasteners on 11 1/4" panel, 4 on 12 5/8", 5 on 15 1/4")
4. Seal formed neoprene closure into place in "Z" closure.
5. Install headwall transition over "Z" closure.
6. Apply counterflashing over the headwall trim, as required.

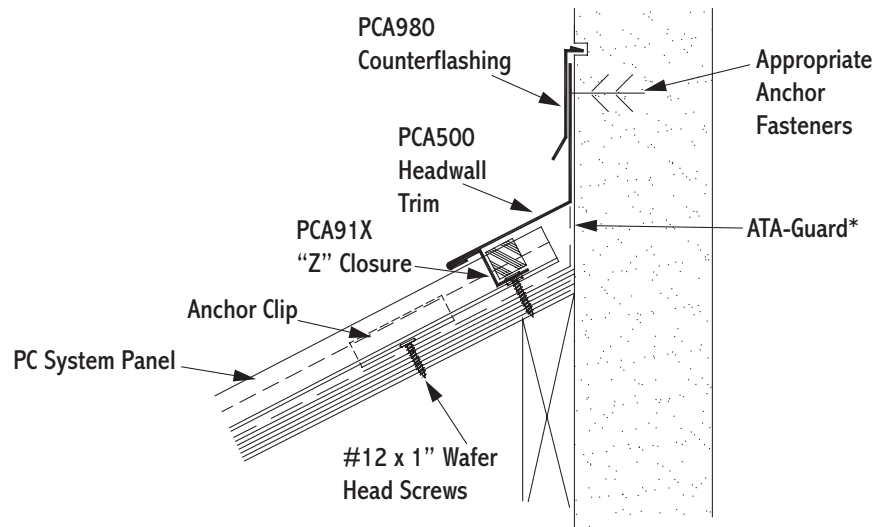

# Shed Ridge Detail

1. Install metal panel up to the roof peak.
2. Cut "Z" closure to fit between seams and install in butyl tape.
3. Fasten "Z" closure in bed of sealant at top of panel. (Use 3 fasteners on 11 1/4" panel, 4 on 12 5/8", 5 on 15 1/4")
4. Seal formed neoprene closure into place in "Z" closure.
5. Fasten starter cleat to face of trim boards at 2" below ridge line.
6. Install shed ridge cap trim over "Z" closure and starter cleat.

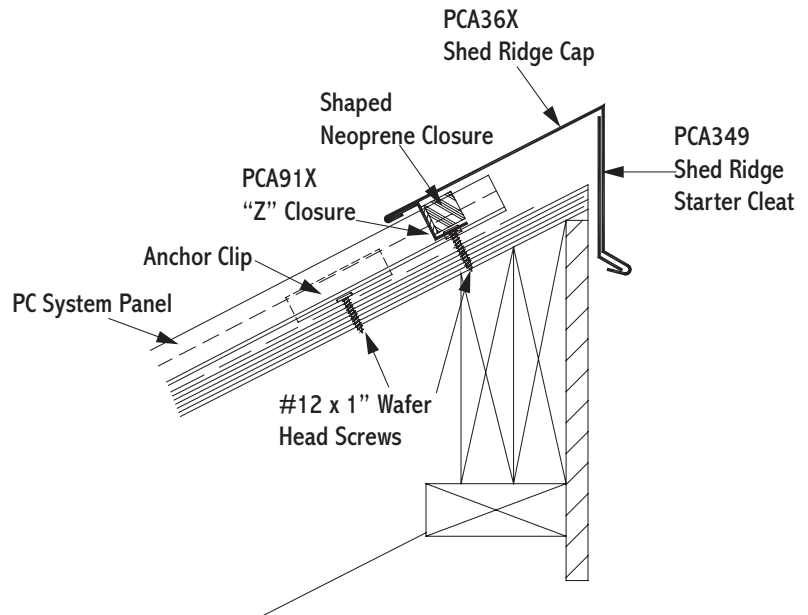

# Sidewall Detail

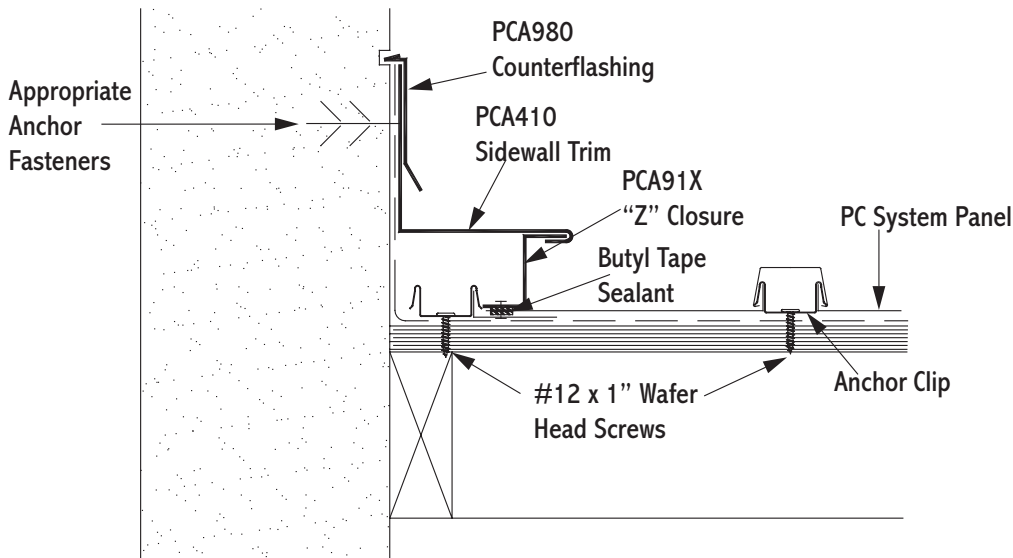

1. Install metal panel up to within 1" of the sidewall.
2. Fasten "Z" closure in bed of butyl sealant at top of panel with pop rivets.
3. Fasten sidewall trim over "Z" closure to face of sidewall.
4. Apply counterflashing over the sidewall trim, and seal into reglet.

## Note Regarding Trim Details

The application of flashing and trim requires a detailed approach. Consideration should be given to the roof's geometry and course it creates for water run-off. Location of gutters and the use of snow retention systems should also be considered. Proper planning regarding the sequence of material overlap is critical. Sealants, such as butyl tapes and tripolymers, should be used at overlapping trim edges, in conjunction with exposed fasteners, and to seal flashings and other ancillaries. All fasteners should be properly tightened and not overdriven at an angle. Fasteners that are too loose can "back out" over time. An overdriven fastener may cause a depression in the material, which becomes a collection point for standing water.

# Pipe Detail

- |   |   |   |   |   |
|---|---|---|---|---|
| <b>Step 1</b>   | <b>Step 2</b>                               | <b>Step 3</b>   | <b>Step 4</b>                                 | <b>Step 5</b>   |
| Cut on the proper pipe diameter marked on the flashing. | Position over pipe and slide down the pipe. | Apply polyurethane sealant to the bottom of the base. | Mold the flexible base to the panel contours. | Fasten with 1/4" x 1-1/8" drilling fastener every 1-1/2" around the base. |



Pipe drawings provided by Triangle Fasteners

### Tools and Rules:

**Basic Equipment Required:**  
Tie-off ropes, safety harness, long level, ladders, scaffolding with approved planking, extension cords with approved ground plugs and services.

**Additional Tools:**  
Metal folding tool, hammer, chalk line, measuring tape, metal cutting tools - nibblers, drills, hacksaw, utility knife, pop-rivet gun, caulking guns, layout and combination square, C clamps, sheet metal shears (including RH, LH, straight and overhand). Power driven screw gun with proper bits, depth setting nosepiece, variable speed.

**Choose the correct equipment and tools to do the job in a safe manner. Wear safety gear and follow OSHA requirements.**

### Follow of few simple rules:

1. Never cut the panels with an abrasive cut-off wheel or torch, as this will damage the finish.
2. Do not weld the trim or panels.
3. Remove any small burrs left by cutting, screwing or drilling.
4. Remove protective masking immediately after trim is installed.
5. Caution should be taken when unloading the panels to prevent damage.
6. Use appropriate screws for the type of underlayment and long enough to fully penetrate and secure the panel.
7. The stored materials should be kept dry.
8. Do not cut on finished roof. Remove all drill spirals, chips and dust immediately.
9. Seal neoprene closures and soft cell foam by applying appropriate sealant to both surfaces.
10. Put appropriate sealant/butyle tape between overlapping trims.
11. Overlap trims in a manner not to impede the flow of water.

**For further information or assistance, contact our Technical Product Support at 800-468-1441**