

FIELD-LOK

Low Slope Installation Guide

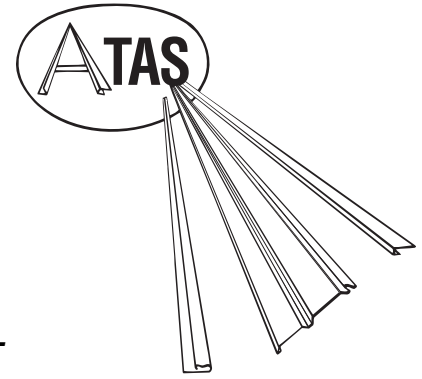

NOTE : This guide to be used for installations with a roof slope of 2:12 or less only on a solid substrate. Consult factory for all other installations.

Field Lock Panel has extra strength, extra height - field seamed panel. Installed with concealed clips and fasteners and a mechanical seamer in a tri-fold lock-in application. Panels are available in smooth or embossed texture in 29 standard ATAS colors are available with premium KYNAR 5000® or HYLAR 5000® finish. Stiffening ribs are optional.

Review and understand complete guide before beginning installation.

This guide has been prepared as suggested details to particular design conditions. Each condition has certain limitations to performance, aesthetics or economics. Professionals qualified to assess this information for a specific project, should determine that the selection and installation are made to their requirements. ATAS **cannot** assume any responsibility for the actual selection and/or installation of materials. The panels, flashings and trim shown in this guide are illustrated over solid and plumb substrate. It is assumed that the structure has been designed and prepared in accordance with local building codes.

FLS Panel

13 3/4" (FLS137) and 18" (FLS180) wide

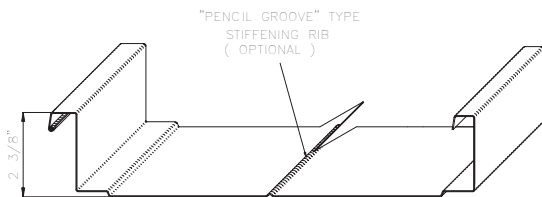

FLS137

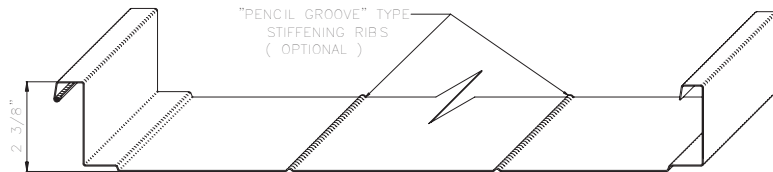
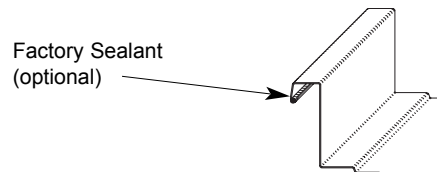

FLS180

Note: The appropriate fasteners must be sufficiently long enough to penetrate through a solid substrate.

Field-Lok Seam Panel Anchoring

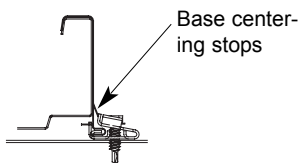

Step #1 - Locate the anchor clip over the right (male) leg of the previously laid panel to afford the proper clip spacing - note how the base centering stops positions and holds the movable section of the clip. DO NOT fully set the screw(s) until all have been located along this seam line.

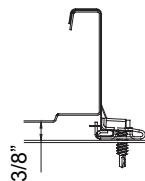

Step #2 - Fully set the screw(s) and note how this action now releases the movable section of the clip and allows for roof movement (expansion / contraction).

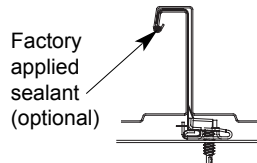

Step #3 - Hook the entire left (female) leg of the next panel over the right (male) leg of the previously installed panel making sure to fully engage the factory installed sealant (optional).

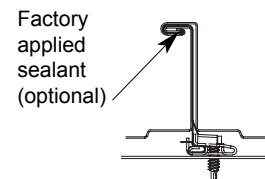

Step #4 - Roll seam the joint utilizing the joint seamer.

Eave Detail

1. Apply ATA-Shield** along eave and up the roof to a point at least 24" beyond outside face of exterior wall.
2. Install 3/8" shim at eave.
3. Install drip edge against fascia trim. Lay ATA-Guard* over eave trim.
4. Trim (cut) both seams back to allow for turn down. Install panel by sliding lower flanged edge over drip edge.
5. See below for proper panel sidelap installation.

*General Note: Before any installation be sure to lay ATA-Shield** in all areas where ice & water can occur. ATA-Guard or appropriate underlayment should be installed over the entire roof.*

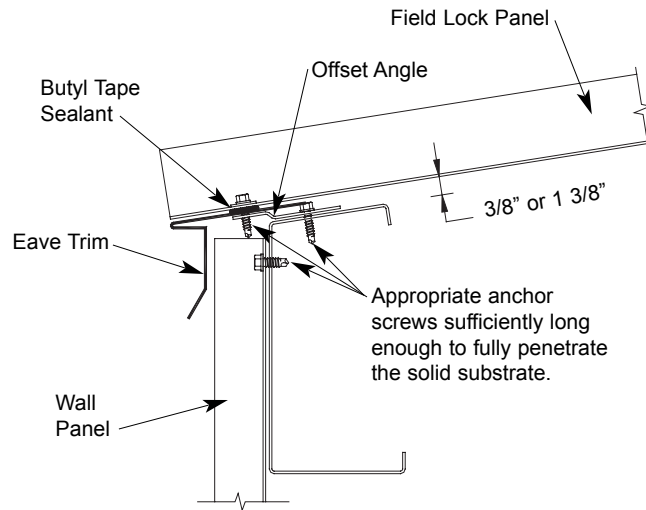

PANEL SIDELAP

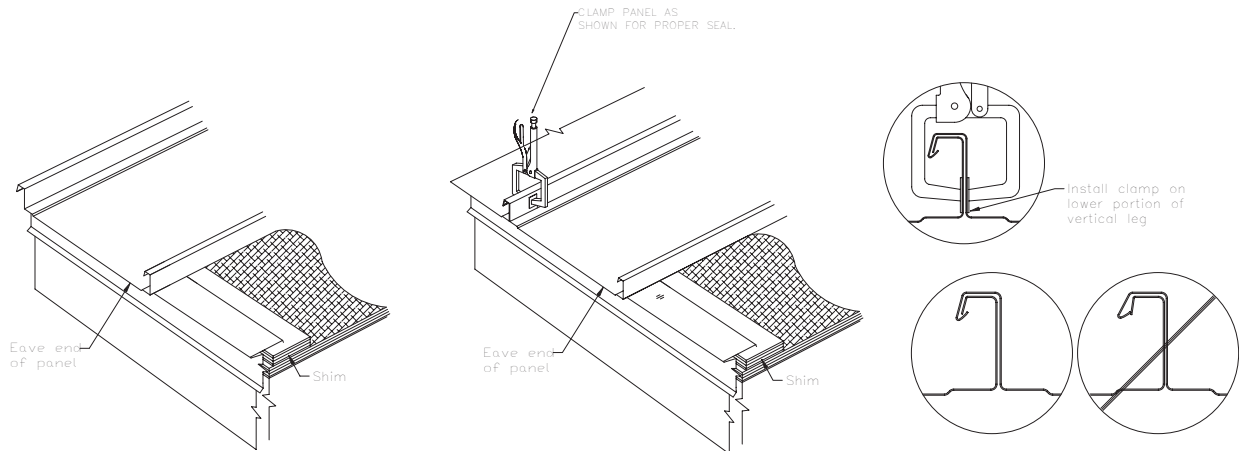

Gable Detail

1. Install underlayment to gable edge. Place 3/8" shim as shown.
2. At gable start detail, install gable trim starter cleat with appropriate fasteners at 2'-0" into fascia board.
3. At end gable, cut panel to appropriate width to allow room for clips at gable end. If panel cut off is 3" or wider install cut off portion of panel underneath last panel w/ butyl tape applied in between the two panels and install clips before installing gable assembly.
4. Apply double-faced butyl sealant as circled in sketch. Fasten "Z" closure to panel with pop-rivets.
5. Install starter cleat at end detail same as start detail.
6. At both ends snap gable/rake trim over starter cleat and "Z" closure to lock into place. Pop-rivet these two pieces together with one pop-rivet per trim length.

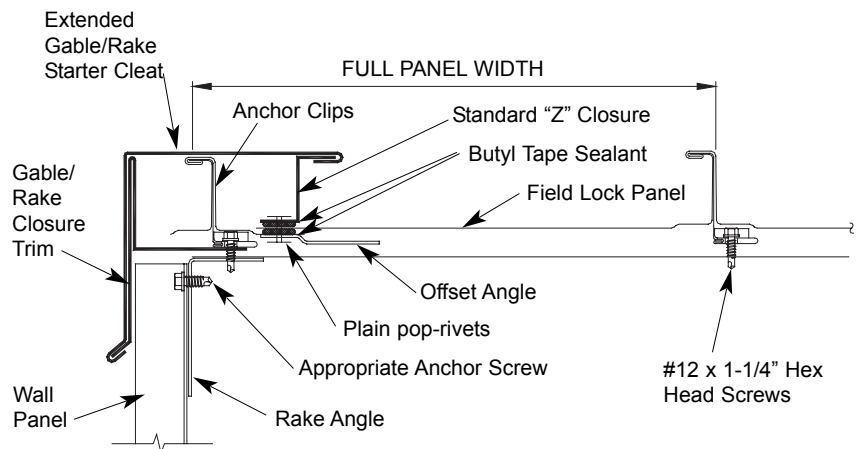

Underlayments: ATA-Guard* is a polyolefin based, 100% asphalt free, high strength reinforced roofing underlayment for use beneath metal roofing on steep slope applications. 1000 sq. ft. per roll at 48" wide.

Underlayments: ATA-Shield** is the recommended self adhesive underlayment for eaves, sidewall and any critical areas exposed to ice damming and extensive water run off. Available in 65'-8" x 39-3/8" rolls (200 sq. ft. per roll).

Hip & Ridge Detail

Hip and ridge applications are handled in the same manner.

1. Install underlayment to roof edge. Place 3/8" shim as shown.
2. Cut "Z" closure to fit between seams and install in butyl tape. Fasten through 3/8" shim to secure panel (use 4 fasteners on 13 3/4", 5 on 18")
3. Seal neoprene strips into "Z" closures .
4. Snap hip/ridge cap over "Z" closures for it to lock into place. Pop-riquet one side only to allow for expansion and contraction.

Notes:

- * Trim must be pop-riqueted to Z in at least one location to control thermal movement.
- * Unless otherwise specified, all fasteners for trim components should be spaced at 2'-0" o.c.
- * Install splice plates at ridge cap joints. Pop rivet splice to one end of ridge cap to allow for expansion and contraction.

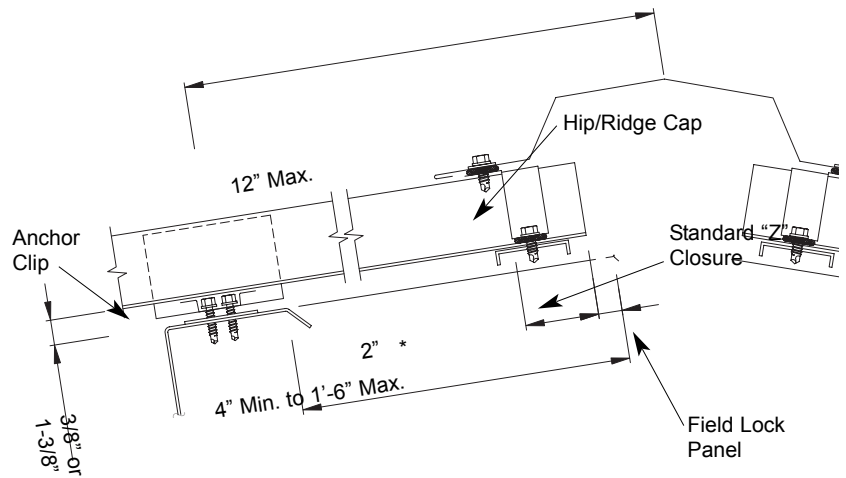

* Varies with roof pitch

Headwall Detail

1. Install underlayment to roof edge. Place 3/8" shim as shown.
2. In standard headwall situation (without venting), run underlayment from roof plane up headwall. Install panels up to headwall.
3. Fasten "Z" closure in bed of sealant at top of panel. Fasten through 3/8" shim to secure panel. (use 4 fasteners on 13 3/4", 5 on 18")
4. Seal neoprene closure into "Z" closure.
5. Install headwall transition over "Z" closure.
6. Apply counterflashing over the headwall trim, as required.

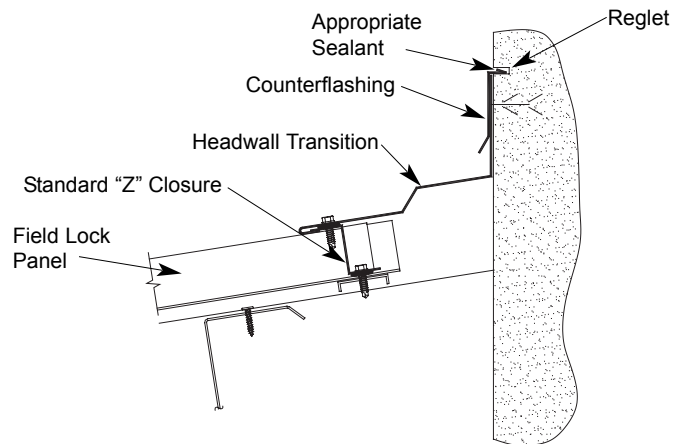

Valley Detail

1. Install ATA-Shield** approximately 18" up both sides of the valley line.
2. Place 3/8" shim as shown.
3. Lay valley pan in valley center. Locate joggle cleat at 4" to 6" from valley center.
4. Install joggle cleat. Fasten 6" o.c. through butyl tape and pan into 3/8" shim and substrate.
5. Turn under edge of panel to slide into joggle cleat. Fasten with clips at 2'-0" o.c.

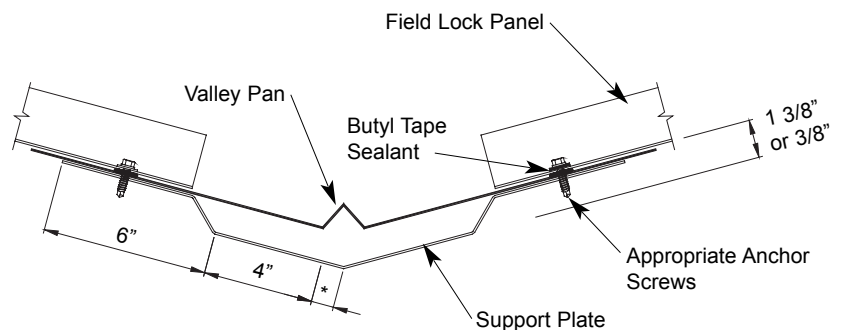

* Varies with roof pitch

Sidewall Detail

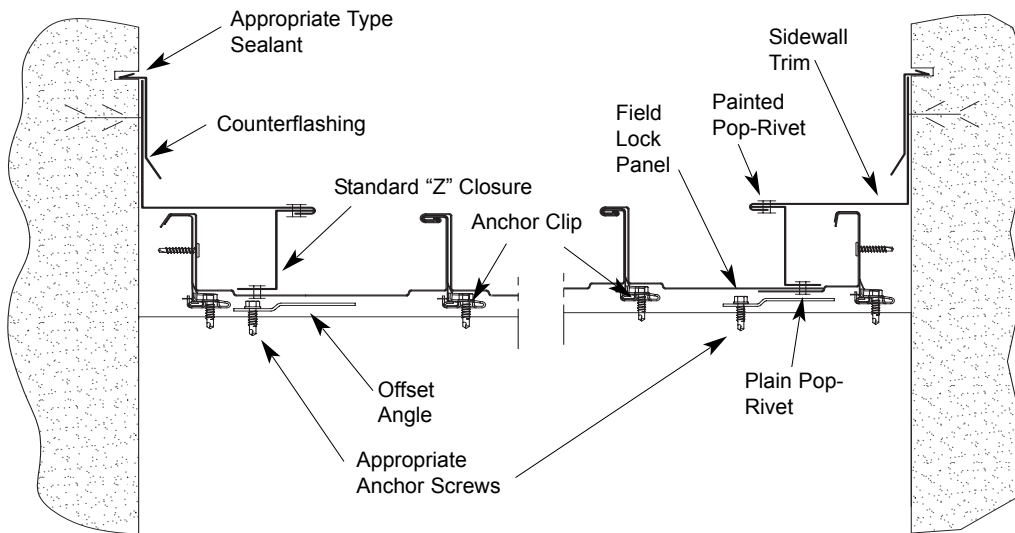

1. Install underlayment to sidewall. Place 3/8" shim as shown.
2. Install metal panel up to within 1" of the sidewall.
3. Fasten "Z" closure in bed of butyl sealant at top of panel as shown.
4. Fasten sidewall trim over "Z" closure to face of sidewall.
5. Apply counterflashing over the sidewall trim, and seal into reglet.

NOTE: Trims should be fastened to substrate and sidewall using a #12 x 1" wafer head screw.

Note Regarding Trim Details

The application of flashing and trim requires a detailed approach. Consideration should be given to the roof's geometry and course it creates for water run-off. Location of gutters and the use of snow retention systems should also be considered. Proper planning regarding the sequence of material overlap is critical. Sealants, such as butyl tapes and tripolymers, should be used at overlapping trim edges, in conjunction with exposed fasteners, and to seal flashings. All fasteners should be properly tightened and not overdriven at an angle. Fasteners that are too loose can "back out" over time. An overdriven fastener may cause a depression in the material, which becomes a collection point for standing water.

Pipe Detail

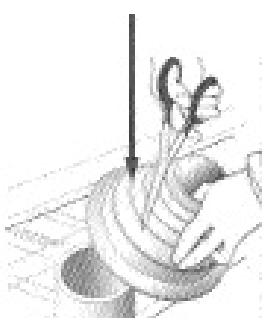
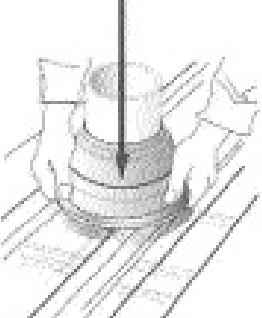
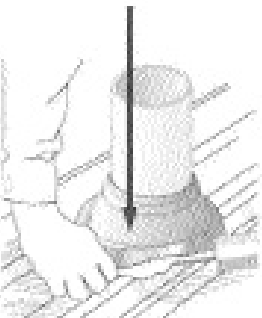
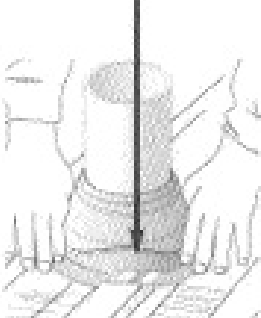
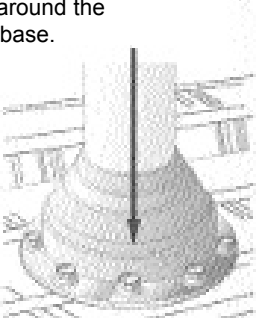
<p>Step 1 Cut on the proper pipe diameter marked on the flashing.</p> 	<p>Step 2 Position over pipe and slide down the pipe.</p> 	<p>Step 3 Apply polyurethane sealant to the bottom of the base.</p> 	<p>Step 4 Mold the flexible base to the panel contours.</p> 	<p>Step 5 Fasten with 1/4" x 1-1/8" drilling fastener every 1-1/2" around the base.</p> 
---	--	--	--	--

Pipe drawings provided by Triangle Fasteners

Tools and Rules:

Basic Equipment Required:
Tie-off ropes, safety harness, long level, ladders, scaffolding with approved planking, extension cords with approved ground plugs and services.

Additional Tools:
Metal folding tool, hammer, chalk line, measuring tape, metal cutting tools - nibblers, drills, hacksaw, utility knife, pop-rivet gun, caulking guns, layout and combination square, C clamps, sheet metal shears (including RH, LH, straight and overhand). Power driven screw gun with proper bits, depth-setting nosepiece, variable speed.

Choose the correct equipment and tools to do the job in a safe manner. Wear safety gear and follow OSHA requirements.

Follow of few simple rules:

1. Never cut the panels with an abrasive cut-off wheel or torch, as this will damage the finish.
2. Do not weld the trim or panels.
3. Remove any small burrs left by cutting, screwing or drilling.
4. Remove protective masking immediately after trim is installed.
5. Caution should be taken when unloading the panels to prevent damage.
6. Use appropriate screws for the type of underlayment and long enough to fully penetrate and secure the panel.
7. The stored materials should be kept dry.
8. Do not cut on finished roof. Remove all drill spirals, chips and dust immediately.
9. Seal neoprene closures and soft cell foam by applying appropriate sealant to both surfaces.
10. Put appropriate sealant/butyl tape between overlapping trims.
11. Overlap trims in a manner not to impede the flow of water.

For further information or assistance, contact our Technical Product Support at 800-468-1441