

FLL Panel System
Convex Curved Gable

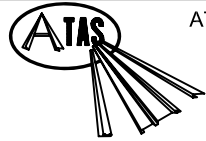

ATAS INTERNATIONAL, INC.
Allentown PA
610-395-8445
Mesa AZ
480-558-7210

TITLE **FLL Curved Gable**

DWG NO. / FILE NO. **FLL Curved Gable** SCALE 3"=1'-0"

DRAWN BY DAS DATE 3-6-06 APPR. BY JEB DATE 5-31-06

REVISION NO. XXXX REVISION DATE MM/DD/YY APPR. BY XXXX APPR. DATE MM/DD/YY

Rev. No.	Revision Date	Drawn By	Description of Revision
0	5-31-06	DAS	FLL Curved Gable

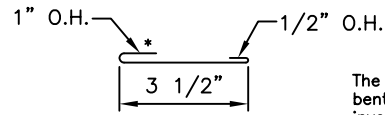

The utility cleat - part #40 - is bent in the field to suit the radii involved.

④① - FLA962 UTILITY CLEAT

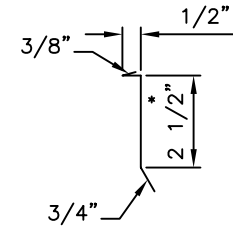

②② - FLA980 COUNTERFLASHING
Supplied in standard 12'-0" lengths - field cut to shorter lengths to suit curvature(s) involved.

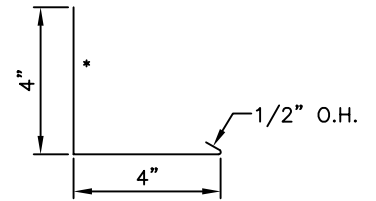
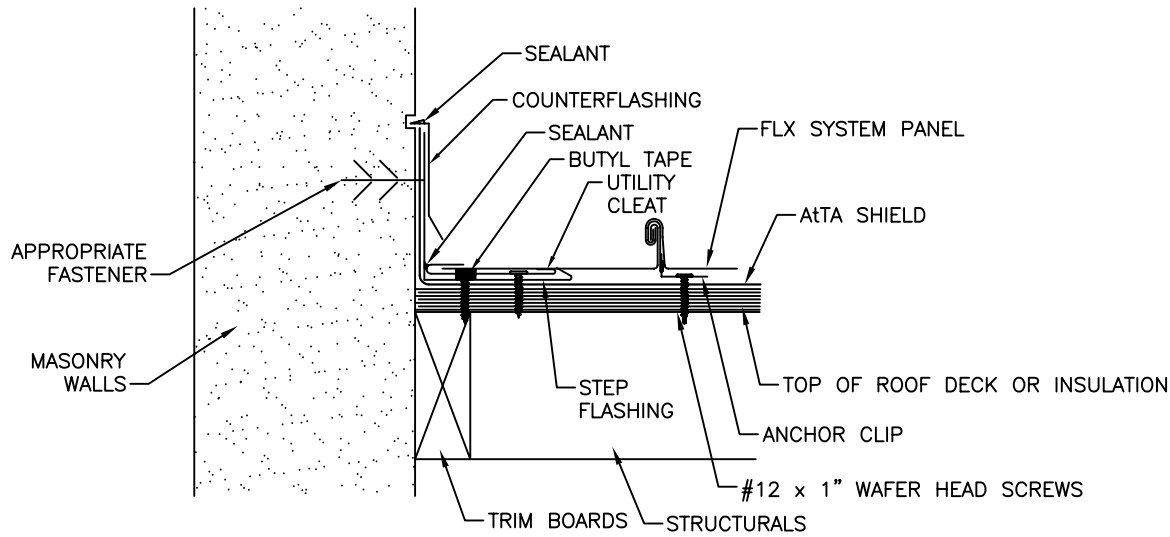

④⑦ - FLA415 STEP FLASHING
Supplied in standard 12'-0" lengths - field cut to shorter lengths to suit curvature(s) involved.

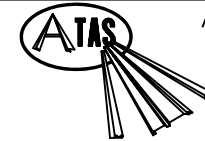

ATAS INTERNATIONAL, INC.
Allentown PA
610-395-8445
Mesa AZ
480-558-7210

TITLE **FLX Curved Rake Sidewall**

DWG NO. / FILE NO. **FLX Curved Rake Sidewall** SCALE 3"=1'-0"

DRAWN BY DAS DATE 3-6-06 APPR. BY JEB DATE 5-31-06

REVISION NO. XXXX REVISION DATE MM/DD/YY APPR. BY XXXX APPR. DATE MM/DD/YY

Rev. No.	Revision Date	Drawn By	Description of Revision
0	5-31-06	DAS	FLX Curved Rake Sidewall

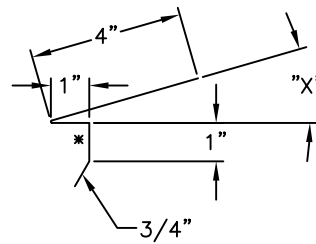
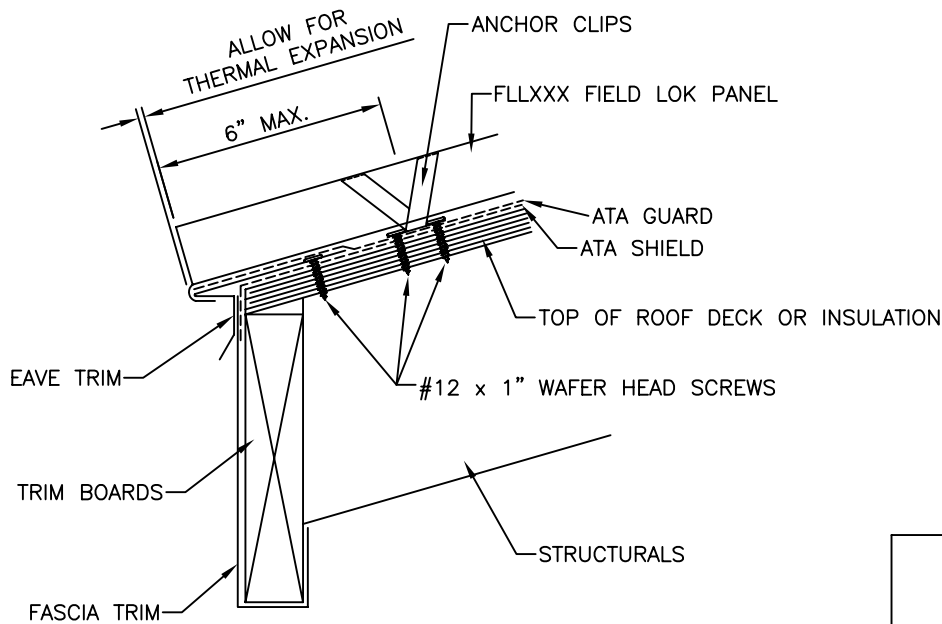

⑤ - EAVE TRIM
For roof slopes 2/12 to 4/12

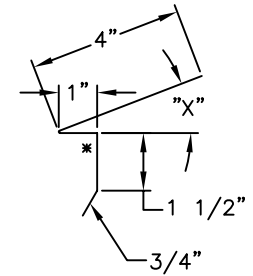

⑤ - EAVE TRIM
For roof slopes 4/12 to 8/12

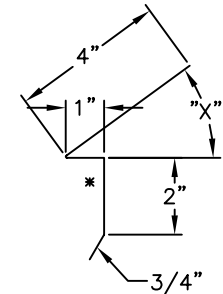

⑤ - EAVE TRIM
For roof slopes 8/12 to 12/12

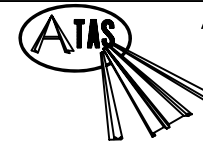

ATAS INTERNATIONAL, INC.
Allentown PA
610-395-8445
Mesa AZ
480-558-7210

TITLE **FLL Eave - Ply**

DWG NO. / FILE NO. **FLL Eave - Ply** SCALE **3"=1'-0"**

DRAWN BY **DAS** DATE **3-6-06** APPR. BY **JEB** DATE **5-31-06**

REVISION NO. **XXXX** REVISION DATE **MM/DD/YY** APPR. BY **XXXX** APPR. DATE **MM/DD/YY**

Rev. No.	Revision Date	Drawn By	Description of Revision
0	5-31-06	DAS	FLL Eave - Ply

FLL/FLX135 PANEL CLIPS

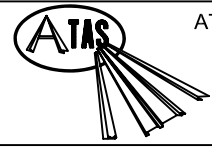
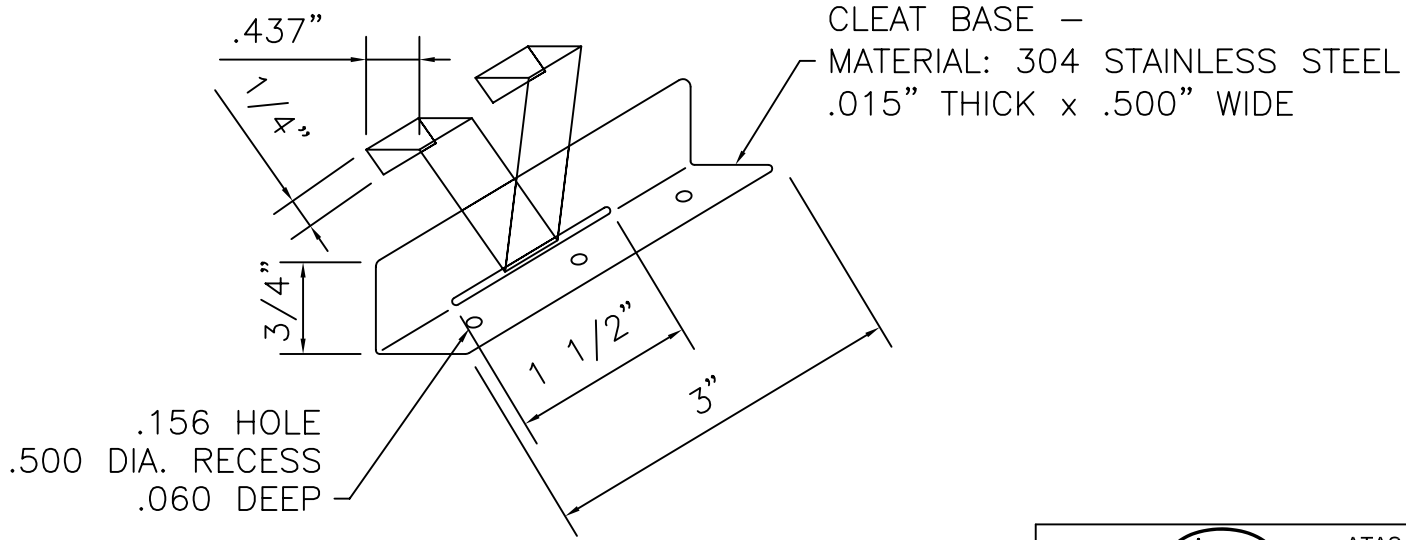

ATAS INTERNATIONAL, INC.
 Allentown PA
 610-395-8445
 Mesa AZ
 480-558-7210

TITLE		FLX FLL Panel Clips					
DWG NO. / FILE NO.		FLX FLL Panel Clips				SCALE	3"=1'-0"
DRAWN BY	DAS	DATE	3-6-06	APPR. BY	JEB	DATE	5-31-06
REVISION NO.	XXXX	REVISION DATE	MM/DD/YY	APPR. BY	XXXX	APPR. DATE	MM/DD/YY

Rev. No.	Revision Date	Drawn By	Description of Revision
0	5-31-06	DAS	FLX FLL Panel Clips

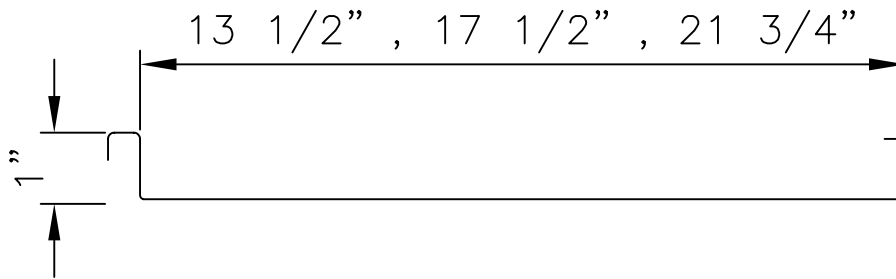

FLL - 1" Field Lok Panel
Panel Profile

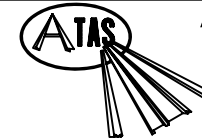

ATAS INTERNATIONAL, INC.
 Allentown PA
 610-395-8445
 Mesa AZ
 480-558-7210

TITLE		FLL Panel Profile					
DWG NO. / FILE NO.		FLL Panel Profile				SCALE	1"=1"
DRAWN BY	DAS	DATE	3-6-06	APPR. BY	JEB	DATE	5-31-06
REVISION NO.	XXXX	REVISION DATE	MM/DD/YY	APPR. BY	XXXX	APPR. DATE	MM/DD/YY

Rev. No.	Revision Date	Drawn By	Description of Revision
0	5-31-06	DAS	FLL Panel Profile

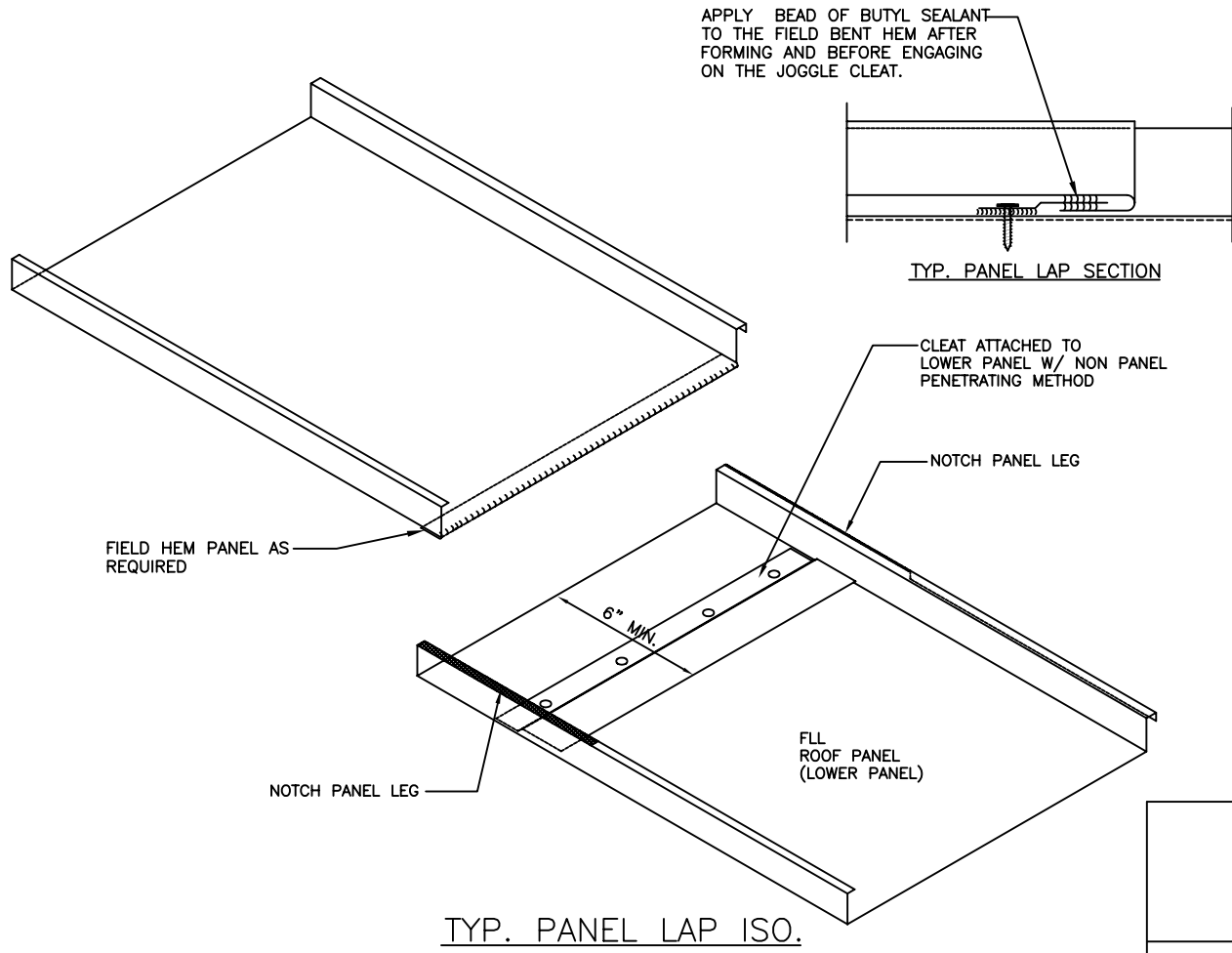

APPLY BEAD OF BUTYL SEALANT TO THE FIELD BENT HEM AFTER FORMING AND BEFORE ENGAGING ON THE JOGGLE CLEAT.

TYP. PANEL LAP SECTION

TYP. PANEL LAP ISO.

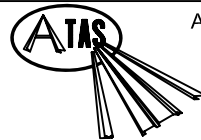

ATAS INTERNATIONAL, INC.
 Allentown PA
 610-395-8445
 Mesa AZ
 480-558-7210

TITLE		FLL Splice					
DWG NO. / FILE NO.		FLL Splice				SCALE	3"=1'-0"
DRAWN BY	DAS	DATE	3-6-06	APPR. BY	JEB	DATE	5-31-06
REVISION NO.	XXXX	REVISION DATE	MM/DD/YY	APPR. BY	XXXX	APPR. DATE	MM/DD/YY

Rev. No.	Revision Date	Drawn By	Description of Revision
0	5-31-06	DAS	FLL Splice

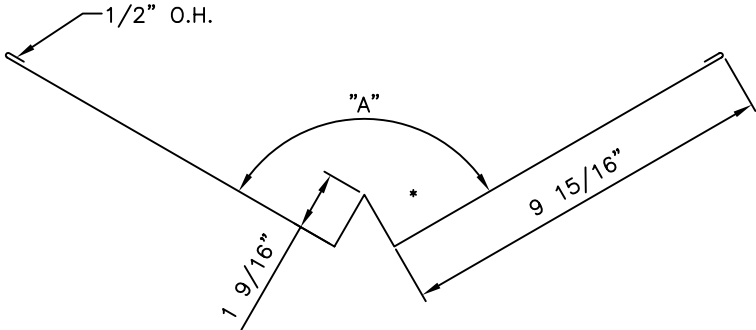

VALLEY PAN

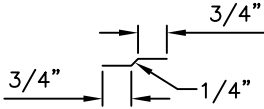

JOGGLE CLEAT

Will be furnished in either 24 ga. steel or .032 aluminum. No particular color.

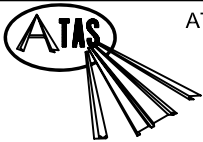
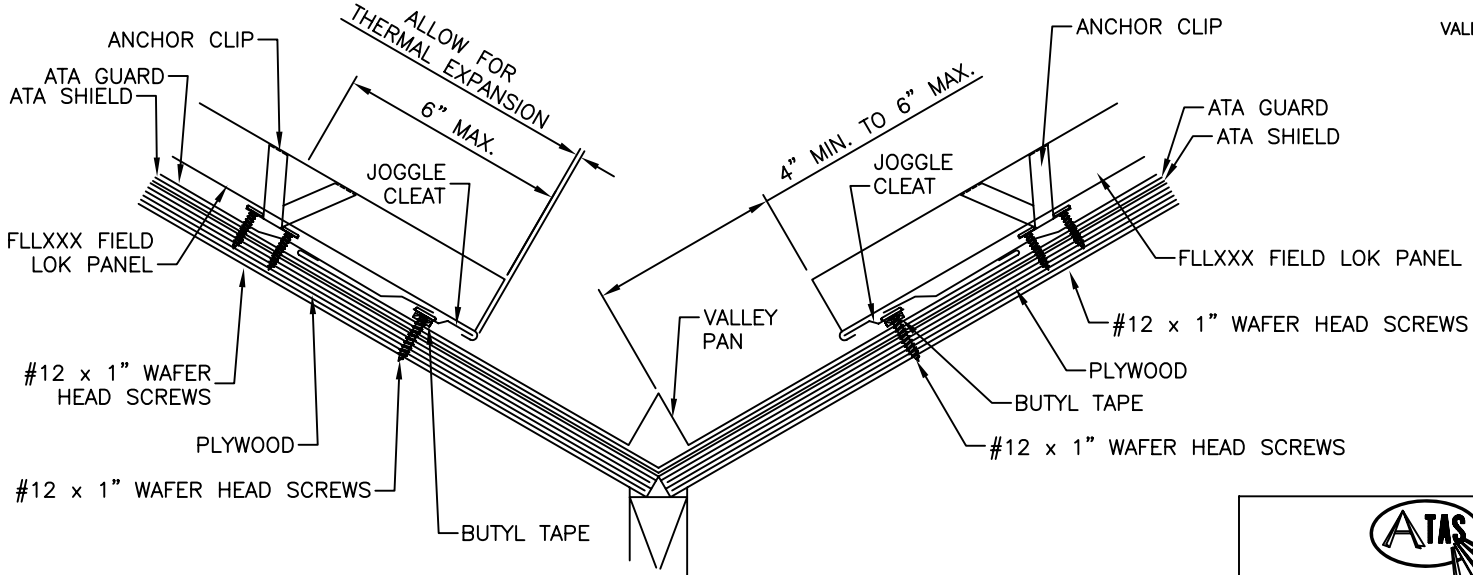

ATAS INTERNATIONAL, INC.
 Allentown PA
 610-395-8445
 Mesa AZ
 480-558-7210

TITLE **FLL Valley - Ply**

DWG NO. / FILE NO. **FLL Valley - Ply** SCALE **3"=1'-0"**

DRAWN BY **DAS** DATE **3-6-06** APPR. BY **JEB** DATE **5-31-06**

REVISION NO. **XXXX** REVISION DATE **MM/DD/YY** APPR. BY **XXXX** APPR. DATE **MM/DD/YY**

Rev. No.	Revision Date	Drawn By	Description of Revision
0	5-31-06	DAS	FLL Valley - Ply