

# CastleTop®

## Installation Guide



**Review and understand complete guide before beginning installation.**

This guide has been prepared as suggested details to particular design conditions. Each condition has certain limitations to performance, aesthetics or economics. Professionals qualified to assess the information regarding suitability for a specific project should determine that the selection and installation are made to their requirements. ATAS **cannot** assume any responsibility for the actual selection and/or installation of materials. The panels, flashings and trim shown in this guide, illustrated over solid and plumb substrate, assume that the structure has been designed and prepared in accordance with local building codes.

**CastleTop** is a diamond shaped flat metal shingle. These shingles have a unique locking feature that allow for easy installation. The overlapping shingles have a turned down edge on the lower front and a turned up edge on the upper front. The panel is 15 3/4" square, net coverage is 13 5/8" x 13 5/8". There are approximately 78 shingles per 100 square feet. The CastleTop shingle is packed 39 shingles per carton, which equates to approximately half of a square.

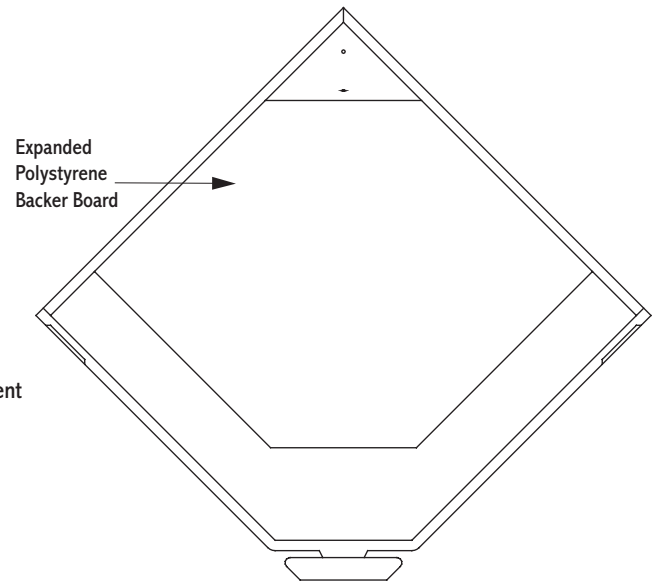
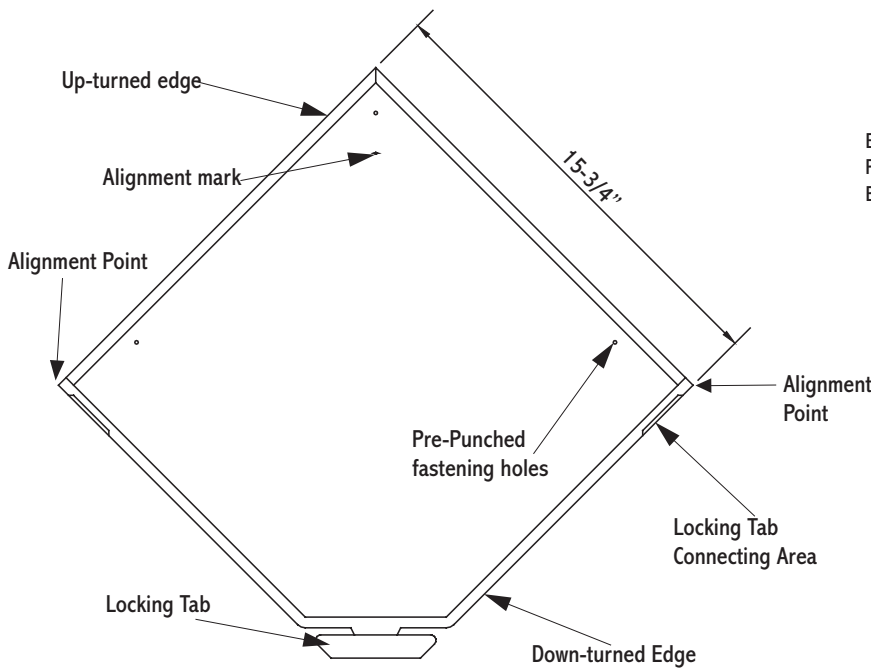

Strike square horizontal chalk line at shingle course as a "benchmark" to work at opposite side of valley.

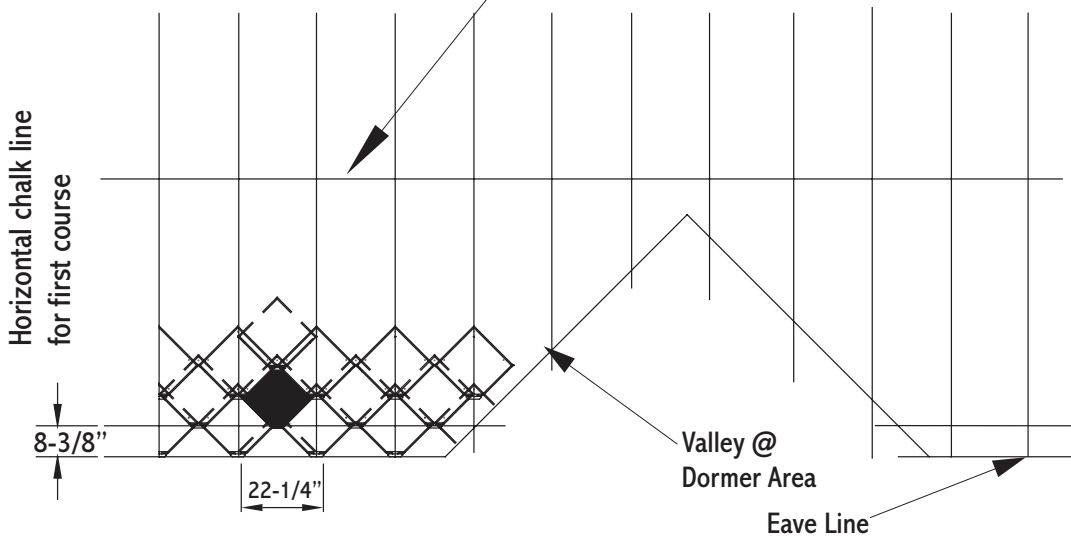

### Shingle Layout

It is recommended to apply waterproof membrane, such as ATA-Shield\*\*, at eave, gable, and valley. Place ATA-Guard\* underlayment up from the eave. For re-roof applications, remove the extended roof material and old drip edge. After Starter Trim is installed (see page 2), snap a horizontal chalk line at 8 3/8" from the edge after squaring up eave. Snap vertical lines at 11 1/8" o.c. Line-up shingle corners with chalk lines to assure square alignment of the shingles. To aid in squaring of shingle, make sure alignment points meet at the alignment mark of the lower course. Shingles are secured with three fasteners per shingle.

*Helpful hint: to square-up the shingle, line up the top hole with the vertical line.*

Published panel width dimensions are to be considered as nominal dimensions. Overall panel width dimensions may vary during installation due to adjustments to accommodate as built roof conditions.

# Eave Detail

1. When applying in a re-roof application, cut back existing shingles and drip edge to be flush with the eave and gable lines. Apply ATA-Shield at eave.
2. Install Drip Edge/Starter Trim. Place lap joint of starter trim at center of shingles to hide seam. Fasteners should be located under the center of each shingle.
3. Apply ATA-Guard to entire roof.
4. Remove the foam backer from lower half of the first row of shingles to assure a flat seal onto the starter trim.
5. Cut lower part of locking edge from shingle (see detail); bend the remaining tab inward under edge of starter trim to avoid wind uplift. Fasteners must penetrate solid substrate.

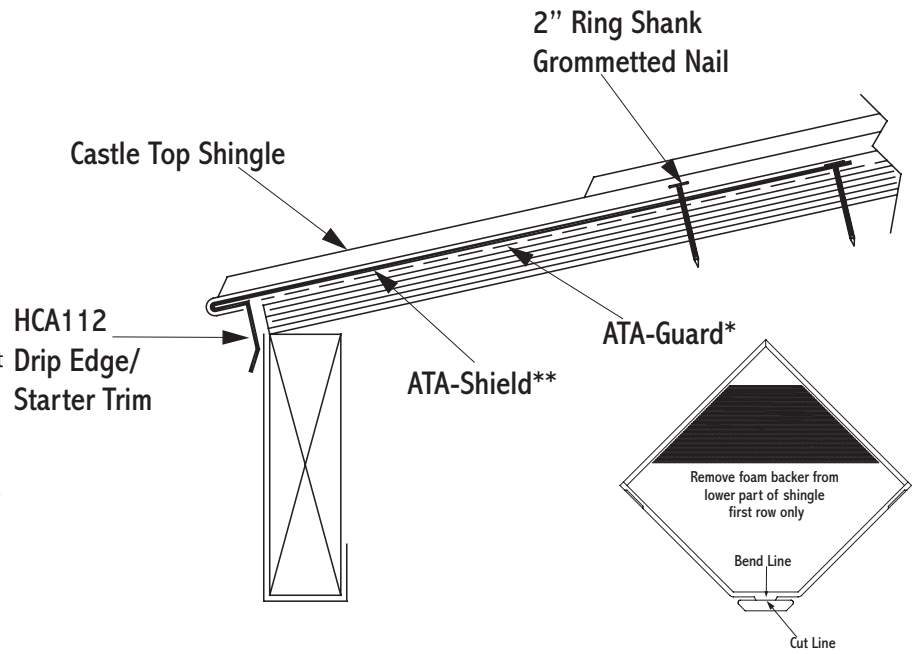

# Gable Detail

1. Install Channel Trim on gable edge, fasten into the substrate 12" o.c.
2. Insert cut edge of shingles into channel trim.
3. Hook Gable trim over channel, fasten with appropriate fasteners.

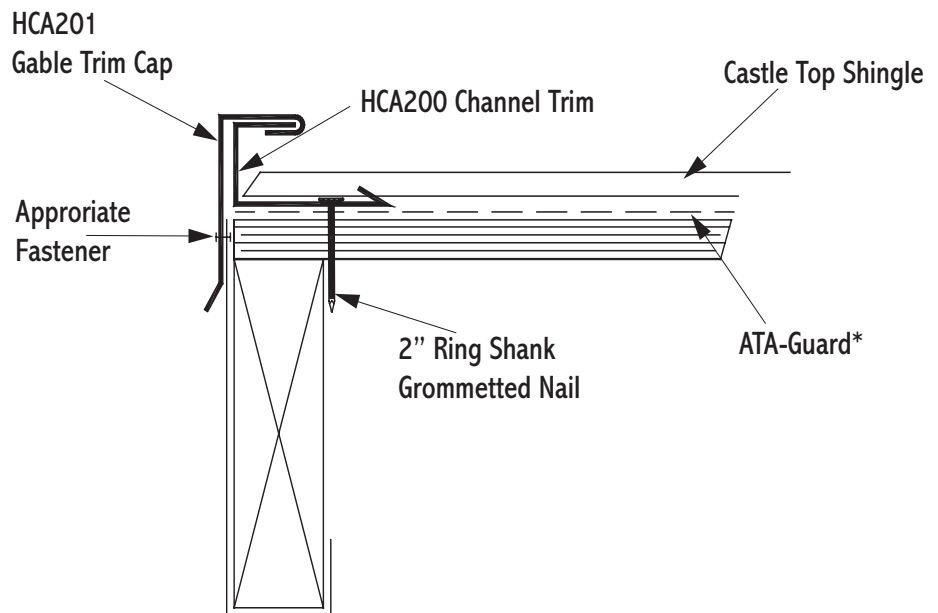

# Valley Detail

1. Install ATA-Shield\*\* 18" up both side of the valley line.
2. Install the valley with the joggle cleat maintaining a 3" clearance from valley's center. Place butyl tape between joggle cleat and pan. Fasten through tape into the substrate 6" o.c. max.
3. Overlap valley pans by a minimum of 6". Apply butyl tape/caulk between all valley metals.
4. Cut backer foam 1" from cut edge of shingle and turn shingle under as shown.
5. Hook shingles onto the joggle cleat and lay in the valley pan and fasten. Maintain square line-up of shingles.

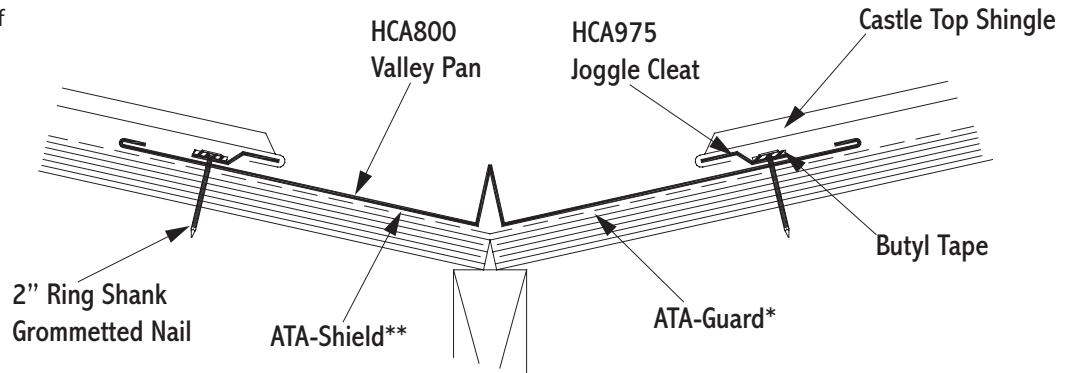

**Underlayments:** ATA-Guard\* is a polyolefin based, 100% asphalt free, high strength reinforced roofing underlayment for use beneath metal roofing on steep slope applications. 1000 sq. ft. per roll at 48" wide.

**Underlayments:** ATA-Shield\*\* is the recommended self adhesive underlayment for eaves, sidewall and any critical areas exposed to ice damming and extensive water run off. Available in 65'-8" x 39 3/8" rolls (200 sq. ft. per roll).

# Hip & Ridge Detail

Hip and ridge applications are handled in the same manner.

1. Install Castle Top roof shingles to meet at hip/ridge.
2. Apply expandable sealant tape to ridge cap; place just behind returned edge of cap.
3. Secure the cap with 2" x 5/16" painted gasketed screws on each side of ridge at approximately 2'-0" o.c. Make sure the screw penetrates soft cell closure between metals.

*Note: Make sure to fasten the caps to the high point on the shingle in order to avoid dimpling, and make sure the screw penetrates the cap through the expandable sealant tape into the solid substrate. Ridge caps can accommodate standard ridge venting products. Refer to venting manufacturer's instructions and local building code requirements.*

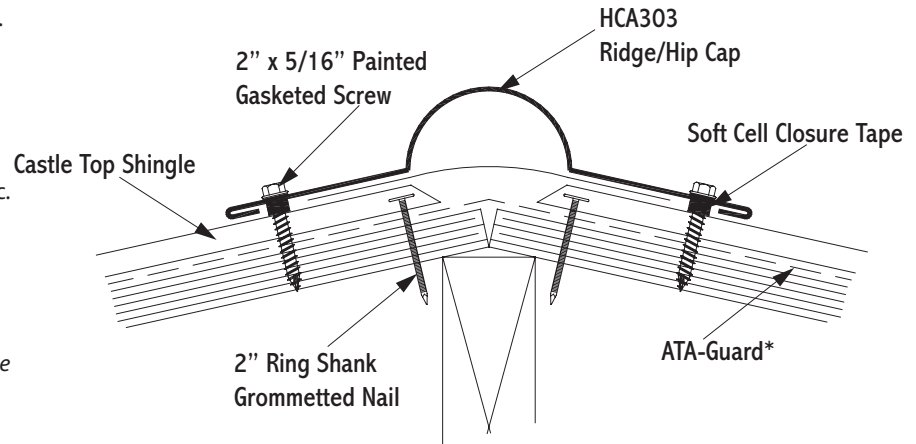

# Headwall Detail

1. Install the shingles up to the headwall.
2. Depending on wall treatment, cut reglet in wall.
3. Apply soft cell closure tape to the headwall trim just behind returned hem of headwall.
4. Lay headwall trim over shingles while insuring that the perpendicular section is flush to the wall.
5. Secure the headwall with 2" x 5/16" painted gasketed screws at approximately 2'-0" o.c. Make sure the screw penetrates soft cell closure between metals.
6. Install counterflashing or wall treatment over headwall.

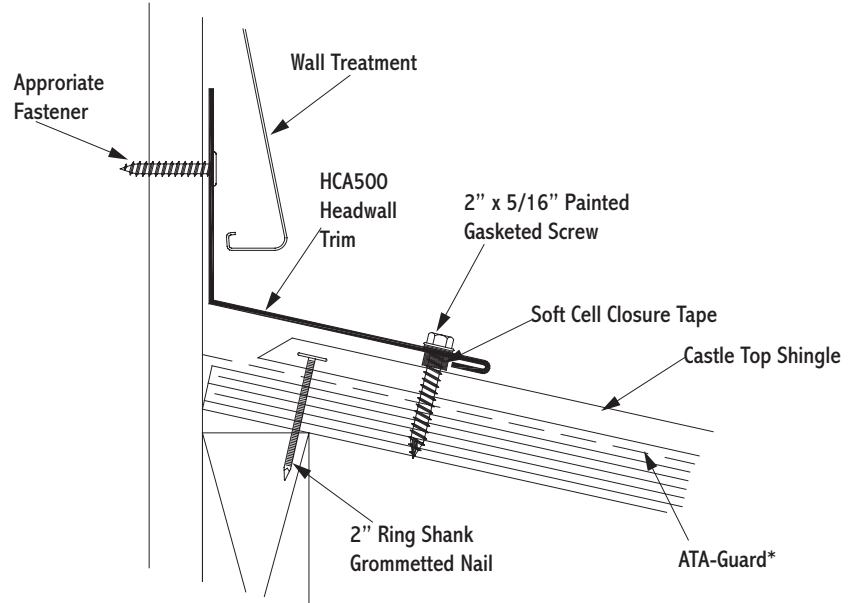

# Shed Ridge Detail

1. Install metal shingle up to the roof peak.
2. Apply soft cell closure tape on the inside of the shed ridge cap just above the hem.
3. Lay shed ridge trim over shingles while insuring that the cap is tight against the peak.
4. Secure shed ridge cap with 2" x 5/16" painted gasketed screws at 24" o.c., making sure to fasten through tape and shingle into solid substrate.

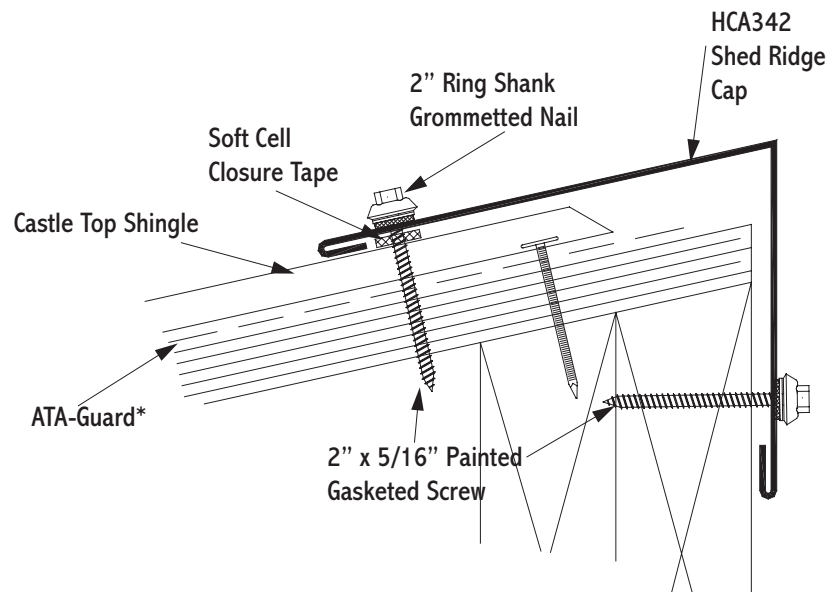

# Sidewall Detail

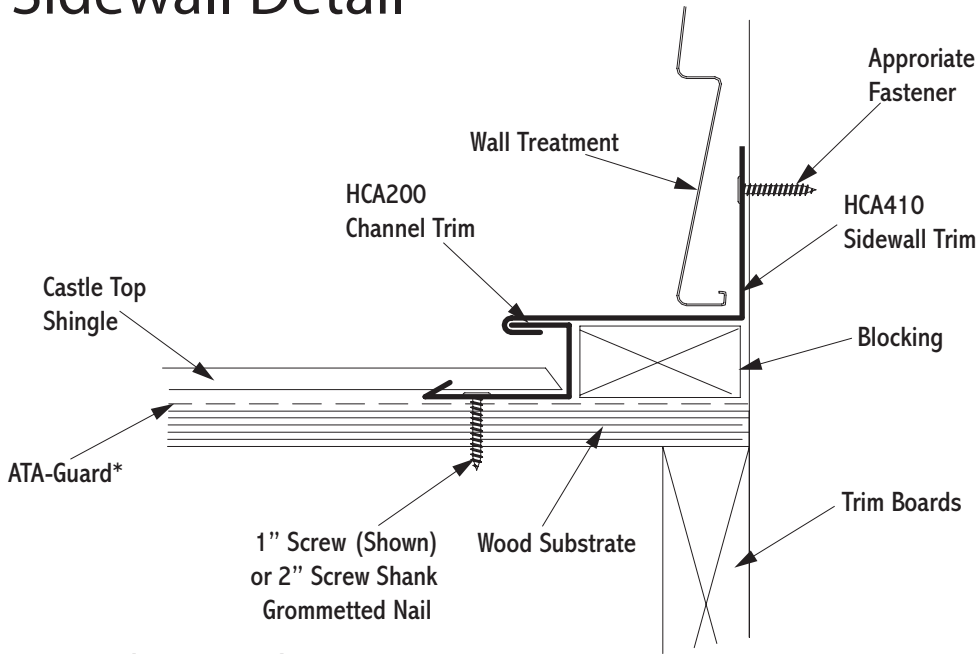

1. Install ATA-Shield\*\* along roof plane and up sidewall.
2. Install channel trim tight against the wall; fasten into the substrate 12" o.c.
3. Place panel into channel, fasten.
4. Apply soft cell closure tape in channel.
5. Install sidewall trim. Secure to the exterior wall.
6. Install wall treatment or counterflashing.

## Note Regarding Trim Details

The application of flashing and trim requires a detailed approach. Consideration should be given to the roof's geometry and course it creates for water run-off. Location of gutters and the use of snow retention systems should also be considered. Proper planning regarding the sequence of material overlap is critical. Sealants, such as butyl tapes and tripolymers, should be used at overlapping trim edges, in conjunction with exposed fasteners, and to seal flashings. All fasteners should be properly tightened and not overdriven at an angle. Fasteners that are too loose can "back out" over time. An overdriven fastener may cause a depression in the material, which becomes a collection point for standing water.

# Pipe Detail

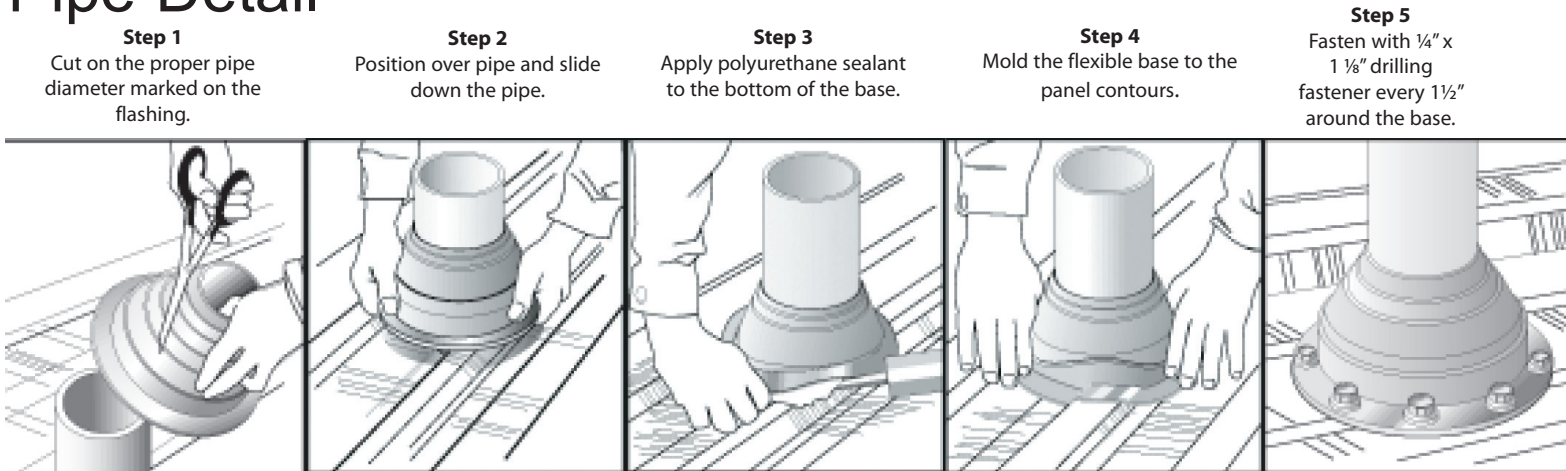

Pipe drawings provided by Triangle Fasteners

### Tools and Rules:

#### Basic Equipment Required:

Tie-off ropes, safety harness, long level, ladders, scaffolding with approved planking, extension cords with approved ground plugs and services.

#### Additional Tools:

Metal folding tool, hammer, chalk line, measuring tape, metal cutting tools - nibblers, drills, hacksaw, utility knife, pop-rivet gun, caulking guns, layout and combination square, C clamps, sheet metal shears (including RH, LH, straight and overhand). Power driven screw gun with proper bits, depth-setting nosepiece, variable speed.

**Choose the correct equipment and tools to do the job in a safe manner. Wear safety gear and follow OSHA requirements.**

### Follow these simple rules:

1. Never cut the panels with an abrasive cut-off wheel or torch, as this will damage the finish.
2. Do not weld the trim or panels.
3. Remove any small burrs left by cutting, screwing or drilling.
4. Remove protective masking immediately after trim and panels are installed.
5. Caution should be taken when unloading the panels to prevent damage.
6. Use appropriate screws for the type of underlayment and long enough to fully penetrate and secure the panel.
7. The stored materials should be kept dry.
8. Do not cut on finished roof. Remove all drill spirals, chips and dust immediately.
9. Seal neoprene closures and soft cell foam by applying appropriate sealant to both surfaces.
10. Put appropriate sealant/butyl tape between overlapping trims.
11. Overlap trims in a manner not to impede the flow of water.